

TECHNICAL MANUAL

OPERATOR'S, ORGANIZATIONAL, DIRECT AND GENERAL
SUPPORT MAINTENANCE MANUAL

HEATER, SPACE, MULTI-FUEL, WITH BLOWER,
6,000 BTU/HR (HUNTER MODEL UH-68F)

NSN 4520-01-050-5628

This copy is a reprint which includes
current pages from Changes 1 through 3.

HEADQUARTERS, DEPARTMENT OF THE ARMY

15 JULY 1980

CHANGE
NO. 3

HEADQUARTERS
DEPARTMENT OF THE ARMY
WASHINGTON, D.C. 20 NOVEMBER 1990

Operator, Organizational, Direct Support and General Support Maintenance Manual

**HEATER, SPACE, MULTIFUEL, WITH BLOWER,
6,000 BTU/HR, 120 VAC
(HUNTER MODEL UH-68F) NSN 4520-01-050-5628**

Approve for public release; distribution is unlimited

TM 5-4520-241-14, 15 July 1980 is changed as follows:

1. Remove and insert pages as indicated below. New or changed text material is indicated by a vertical bar in the margin. An illustration change is indicated by a miniature pointing hand.

Remove pages	Insert pages
2-7/(2-8 blank)	2-7 and 2-8

2. Retain this sheet in front of manual for references purposes.

By Order of the Secretary of the Army:

CARL E. VUONO
General, United States Army
Chief of Staff

Official:

THOMAS F. SIKORA
Brigadier General, United States Army
The Adjutant General

DISTRIBUTION:

To be distributed in accordance with DA Form 12-25E, (qty rqr block no. 1006).

CHANGE }
NO. 2 }

HEADQUARTERS
DEPARTMENT OF THE ARMY
WASHINGTON, D.C. 20 January 1988

Operator, Organizational, Direct
Support and General Support
Maintenance Manual

HEATER, SPACE, MULTIFUEL, WITH BLOWER,
60,000 BTU/HR, 120 VAC
(HUNTER MODEL UH-68F)
NSN 4520-01-050-5628

TM 5-4520-241-14, 15 July 1980, is changed as follows:

1. Remove and insert pages as indicated below. New or changed text material is indicated by a vertical bar in the margin. An illustration change is indicated by a miniature pointing hand.

Remove pages	Insert pages
i and ii	i and ii
4-5 and 4-6	4-5 and 4-6
4-7 and 4-8	4-7 and 4-8

2. Retain this sheet in front of manual for reference purposes.

By Order of the Secretary of the Army:

CARL E. VUONO
General, United States Army
Chief of Staff

Official:

R. L. DILWORTH
Brigadier General, United States Army
The Adjutant General

DISTRIBUTION:

To be distributed in accordance with DA Form 12-25A, Operator's, Unit, Intermediate Direct Support and Intermediate General Support Maintenance Requirements for Heater, Space, Multifuel, 60,000 BTU (UH-68F).

CHANGE }
NO. 1 }

HEADQUARTERS
DEPARTMENT OF THE ARMY
WASHINGTON, D.C. 13 March 1985

Operator, Organizational, Direct
Support and General Support
Maintenance Manual

for

HEATER, SPACE, MULTIFUEL, WITH BLOWER,
60,000 BTU/HR, 120 VAC
(HUNTER MODEL UH-68F)
NSN 4520-01-050-5628

TM 5-4520-241-14, 15 July 1980, is changed as follows:

1. Remove and insert pages as indicated below. New or changed text material is indicated by a vertical bar in the margin. An illustration change is indicated by a miniature pointing hand.

Remove pages

i and ii
1-1 and 1-2
1-9 and 1-10
3-1 and 3-2
4-9 thru 4-18
A-1/A-2

Insert pages

i and ii
1-1 and 1-2
1-9 and 1-10
3-1 and 3-2
4-9 and 4-10
A-1/A-2

2. Retain this sheet in front of manual for reference purposes.

By Order of the Secretary of the Army:

JOHN H. WICKMAN, JR.
General, United States Army
Chief of Staff

Official:

DONALD J. DELANDRO
Brigadier General, United States Army
The Adjutant General

DISTRIBUTION:

To be distributed in accordance with DA Form 12-25C, Operator's, Organizational, Direct and General Support Maintenance Requirements for Heaters, Space, 60,000 BTU.

WARNING**SHOCK HAZARD**

The ignition system of this heater contains dangerous voltages which can cause severe electrical shock. Be extremely careful when making voltage measurements or other checks with the heater connected to the power source during troubleshooting. Always disconnect the power plug before making any continuity tests or before repairing the heater.

POISONOUS GAS HAZARD

Do not operate this heater in an enclosed area unless exhaust gases are piped to the outside. Do not locate the heater where expelled exhaust gases can be recirculated into inlet air openings of the heated space. The exhaust gases may contain carbon monoxide, a colorless, odorless, deadly poisonous gas. Inhalation of exhaust fumes can cause serious illness or death. Stop heater operation and check exhaust connections if exhaust gas odors are apparent in the enclosure.

HEALTH HAZARD

Clean parts in a well-ventilated area. Avoid inhalation of solvent fumes and prolonged exposure of skin to cleaning solvent. Wash exposed skin thoroughly. Dry cleaning solvent (fed. spec. P-D-680) used to clean parts is potentially dangerous to personnel and property. Do not use near open flame or excessive heat. Flash point of solvent is 100°F (38°C).

DEATH

or serious illness may result from inhalation of exhaust fumes. The heat exchanger confines the combustion gases and directs them to the exhaust pipe. It must be air tight to prevent harmful combustion products from entering the heated enclosure. Any crack or hole through the exchanger walls requires exchanger replacement.

FIRE HAZARD

During operation, the exhaust pipe becomes hot enough to cause combustion of wood or other flammable building material. Provide adequate fire-proofing insulation between the exhaust pipe and wall to prevent fire.

Technical Manual }
 No. 5-4520-241-14 }

HEADQUARTERS
 DEPARTMENT OF THE ARMY
 WASHINGTON, D.C., 15 July 1980

OPERATOR, ORGANIZATIONAL, DIRECT
 SUPPORT AND GENERAL SUPPORT
 MAINTENANCE MANUAL

HEATER, SPACE, MULTIFUEL, WITH BLOWER,
 60,000 BTU/HR, 120 VAC
 (HUNTER MODEL UH-68F)
 NSN 4520-01-050-5628

REPORT ERRORS AND RECOMMENDING IMPROVEMENTS

You can help improve this manual. If you find any mistake or if you know of a way to improve the procedures, please let us know. Mail your letter, DA Form 2028 (Recommended Changes to Publications and Blank Forms), or DA Form 2028-2 located in the back of this manual direct to: Commander, U.S. Army Troop Support Command, ATTN: AMSTR-MCTS, 4300 Goodfellow Boulevard, St. Louis, MO 63120-1798. A reply will be furnished directly to you.

TABLE OF CONTENTS

			Paragraph	Page
CHAPTER	1.	INTRODUCTION		1-1
Section	I.	General	1-1	1-1
	II.	Description and Data.....	1-7	1-3
CHAPTER	2.	OPERATING INSTRUCTIONS		2-1
Section	I.	Operating procedures.....	2-1	2-1
	II.	Operation under unusual conditions	2-7	2-7
CHAPTER	3.	OPERATOR/CREW MAINTENANCE INSTRUCTIONS		3-1
Section	I.	Lubrication instructions.....(Not Applicable)		
	II.	Preventive maintenance checks and services	3-1	3-1
	III.	Troubleshooting.....	3-4	3-3
	IV.	Maintenance procedures	3-6	3-5
CHAPTER	4.	ORGANIZATIONAL MAINTENANCE INSTRUCTIONS		4-1
Section	I.	Service upon receipt of materiel.....	4-1	4-1
	II.	Movement to new worksite	4-6	4-8
	III.	Repair parts, special tools, and equipment.....	4-8	4-9
	IV.	Preventive maintenance checks and services	4-10	4-9

		Paragraph	Page
	V. Troubleshooting.....	4-12	4-19
	VI. Radio interference suppression.....	4-14	4-42
	VII. Maintenance of control box assembly.....	4-19	4-44
	VIII. Maintenance of heater case assemblies	4-24	4-49
	IX. Maintenance of fuel system	4-29	4-56
	X. Maintenance of electrical system	4-34	4-65
	XI. Maintenance of burner assembly	4-39	4-76
	XII. Maintenance of accessory items	4-42	4-80
CHAPTER	5. DIRECT SUPPORT AND GENERAL SUPPORT MAINTENANCE INSTRUCTIONS.....		5-1
Section	I. Repair parts, special tools, and equipment.....	5-1	5-1
	II. Troubleshooting.....	5-4	5-1
	III. General maintenance.....	5-6	5-20
	IV. Removal and installation of major components and assemblies	5-9	5-21
CHAPTER	6. REPAIR OF CONTROL BOX ASSEMBLY	6-1	6-1
CHAPTER	7. REPAIR OF HEATER CASE ASSEMBLY	7-1	7-1
CHAPTER	8. REPAIR OF ELECTRICAL COMPONENTS.....	8-1	8-1
CHAPTER	9. REPAIR OF BURNER ASSEMBLY	9-1	9-1
CHAPTER	10. REPAIR OF HEAT EXCHANGER.....	10-1	10-1
APPENDIX	A. REFERENCES	A-1	A-1
APPENDIX	B. MAINTENANCE ALLOCATION CHART.....	B-1	B-1
APPENDIX	C. COMPONENTS OF END ITEMS LIST.....	C-1	C-1
APPENDIX	D. EXPENDABLE SUPPLIES AND MATERIALS LIST.....	D-1	D-1
INDEX		I-1

LIST OF ILLUSTRATIONS

Number	Title	Page
1-1	Multifuel space heater, left front, three-quarter view.....	1-5
1-2	Multifuel space heater, right rear, three-quarter view	1-6
1-3	Circuit schematic diagram.....	1-7
1-4	Wiring diagram	1-8
2-1	Controls and receptacles	2-4
2-2	Room thermostat	2-6
4-1	Base mounting dimensions	4-2
4-2	Modification required for various mounting positions.....	4-3
4-3	Fuel needle adjustment	4-7
4-4	Flame switch mounting.....	4-23
4-5	Flame switch mounting.....	4-28
4-6	Carburetor inlet screen, needle, and seat	4-30

Number	Title	Page
4-7	Fuel mixer and jet	4-30
4-8	Solenoid assembly	4-32
4-9	Flame switch mounting	4-33
4-10	Fuel needle adjustment	4-35
4-11	Carburetor inlet screen, needle, and seat	4-39
4-12	Fuel mixer and jet	4-39
4-13	Solenoid assembly	4-41
4-14	Primary radio interference suppression components	4-43
4-15	Control box, electrical receptacles, and circuit breaker	4-45
4-16	HEATER-OFF-FAN switch wiring	4-48
4-17	Heater case assembly	4-50
4-18	Side panels and louver linkage	4-52
4-19	Doors and bottom cover	4-54
4-20	Data plates	4-55
4-21	Fuel lines and fittings	4-57
4-22	Fuel filter	4-59
4-23	Carburetor assembly	4-61
4-24	Solenoid assembly	4-65
4-25	Electrical system operation	4-67
4-26	Wiring harness	4-70
4-27	Safety thermostats and flame switch	4-72
4-28	Thermostat and safety switch installation	4-74
4-29	Fuel pump power supply	4-75
4-30	Ignition transformer and cable	4-77
5-1	Combustion motor installation	5-5
5-2	Combustion motor assembly relationship	5-7
5-3	Ventilating motor installation	5-8
5-4	Axial fan installation dimension	5-10
5-5	Heat exchanger insulator installation	5-11
5-6	Combustion motor assembly	5-13
5-7	P.C. Board and transistor installation	5-16
5-8	Transistor connection	5-18
5-9	Control box wiring	5-18
5-10	Bimetallic heater/sensor installation	5-19
5-11	Removal of combustion motor	5-23
5-12	Combustion motor assembly relationship	5-24
5-13	Removal of ventilation motor	5-26
5-14	Ventilating motor fan dimension	5-27
5-15	Removal of burner assembly	5-27
5-16	Removal of heat exchanger	5-29
5-17	Heat exchanger insulator installation	5-30
6-1	Control box wiring harness	6-2
6-2	Wiring diagram	6-4
6-3	Control box cover assembly	6-6
6-4	Transistor connections	6-9
6-5	Control box wiring	6-10
7-1	Heater case assembly	7-2
8-1	Wiring harness	8-2
8-2	Combustion motor	8-5
8-3	Fuel pump power supply	8-8
9-1	Burner assembly	9-2
10-1	Heat exchanger	10-1

LIST OF TABLES

Number	Title	Page
1-1	Tabulated Data.....	1-9
2-1	Controls and Receptacles.....	2-2
3-1	Operator/Crew Preventive Maintenance Checks and Services	3-2
3-2	Operator/Crew Troubleshooting.....	3-3
4-1	Organizational Preventive Maintenance Checks and Services	4-10
4-2	Organizational Maintenance Troubleshooting.....	4-20
5-1	Direct Support and General Support Troubleshooting.....	5-2

CHAPTER 1
INTRODUCTION

SECTION I. GENERAL

1-1. SCOPE

This manual is for your use in operating and maintaining the Heater, Space, Multifuel, with Blower, 60,000 BTU/HR, 120 VAC, Model UH-68F.

1-2. MAINTENANCE FORMS AND RECORDS.

a. Maintenance forms and records that you are required to use are as follows:

- (1) DA Form 2402 (Exchange Tag).
- (2) DA Form 2404 (Equipment Inspection and Worksheet).
- (3) DA Form 2407 (Maintenance Request Used for Requesting Support Maintenance).

b. For additional forms and records pertaining to your particular equipment, refer to TM-38-750 (The Army Maintenance Management System (TAMMS)).

1-3. REPORTING OF ERRORS.

You can help improve this manual. If you find any mistake or if you know of a way to improve the procedures, please let us know. Mail your letter, DA Form 2028 (Recommended Changes to Publication and Blank Forms), or DA Form 2028-2 located in the back of this manual direct to: Commander, U.S. Army Troop Support and Aviation Materiel Readiness Command, ATTN: DRSTS-MTPS, 4300 Goodfellow Boulevard, St. Louis, MO 63120. A reply will be furnished to you.

1-4. EQUIPMENT SERVICEABILITY CRITERIA.

This equipment is not covered by an ESC.

1-5. DESTRUCTION OF ARMY MATERIEL TO PREVENT ENEMY USE.

a. Destruction by Misuse.

- (1) Pour sand and gravel into the fuel supply.

(2) Block air inlet and outlet passages with oil-soaked rags or debris.

b. Mechanical Destruction. Using an axe, pick, mattock, sledge, or any other heavy implement, damage all vital elements such as controls, fuel pump, switches and valves, motor and any other major assemblies and components.

c. Destruction by Fire. Pour fuel over unit and pile quantities of flammable material around unit. Burn assemblies and components on a priority basis if possible. Proper concentration of equipment to be burned will produce a hotter, more destructive fire. Fires should be lit after mechanical destruction has been accomplished.

d. Destruction by Gunfire. Fire on the equipment with the heaviest weapons available, aiming at the major assemblies and controls.

WARNING

Point blank firing at equipment should not be attempted unless the safety of all personnel in the area is assured.

e. Use of Natural Surroundings.

(1) Submergence of equipment and repair parts underwater (lakes, ponds, bogs, swamps, etc.), or by concealment by hiding material in caves or preferably by burial, can be used effectively.

(2) Widely dispersed scattering of material, preferably into heavy underbrush, can serve as a denial or delaying measure. In the event the area is recaptured, effort should be made to recoup concealed items.

1-6. ADMINISTRATIVE STORAGE.

a. General.

(1) Equipment that is placed in administrative storage should be capable of being readied to perform its mission within a 24-hour period or as otherwise may be prescribed by the approving authority.

(2) Report equipment in administrative storage in Materiel Readiness and Unit Readiness reports as prescribed for all reportable equipment.

(3) Perform inspections, maintenance services, and lubrications in accordance with the instructions in this manual.

b. Storage Site.

(1) Select the best available site for storage. Separate stored equipment from equipment in use. Conspicuously mark the area "Administrative Storage."

(2) Covered space is preferable. Open sites should be improved hardstand, if available. Unimproved sites should be firm, well-drained, and kept free of excessive vegetation.

c. Storage Plan.

(1) Store equipment so as to provide maximum protection from the elements and to provide access for inspection, maintenance, and exercising.

(2) Take into account environmental conditions, such as extreme heat or cold; high humidity; blowing sand, dust, or loose debris; soft ground; and take adequate precautions.

d. Maintenance Services and Inspection.

(1) Prior to storage, perform the next scheduled major preventive maintenance checks and services. Inspect and approve equipment.

(2) Correct all shortcomings and deficiencies. Clean the equipment of dirt, grease, and other contaminants.

(3) Remove rust and damaged paint by scraping, wire brushing, sanding, or buffing. Sand to a smooth finish and spot paint, as necessary.

(4) After cleaning and drying, immediately coat unpainted surfaces with an oil or grease as appropriate.

(5) Install all covers; close and secure all openings except those required for venting and draining. Seal openings to prevent entry of rain, snow, or dust. Place equipment and provide adequate blocking to allow for draining of water.

SECTION II. DESCRIPTION AND DATA

1-7. DESCRIPTION.

a. The Model UH-68F Multifuel Space Heater is designed for heating enclosed areas where the maximum output of 60,000 Btu per hour may be required. It operates on 120 volts alternating current, and requires an external fuel pump and fuel supply. The heater may be mounted on either floor or wall in any one of four mounting positions. The unit is controlled by a remote thermostat which can be set to maintain room temperature from 35° to 80°F (1.7° to 26.7°C) up to the rated output of the heater.

b. The heater draws in fresh, cool air through the adjustable louvered side panels or through the return air opening in one end of the heater case if the side panels cannot be used. Combustion air is fed to the burner by a combustion motor. Circulating air is blown across the heat exchanger by the ventilating motor fan, and discharged through a screen at the discharge outlet of the heater.

c. The heater is equipped with a time delay ignition control (flame failure shutdown) to provide for safe, thermostat-controlled starting without continuous operator supervision. If proper ignition does not occur within a predetermined time, power is shut off and manual reset is required. This minimizes the danger of fire or explosion, and protects the heater from damage in case of equipment malfunction or loss of fuel supply.

d. When the heater is operating, another safety control shuts off the flow of fuel if the heater exceeds a preset overheat temperature. The heater will automatically restart when it cools to just below the overheat temperature.

e. The maintenance paragraphs of this manual contain detailed descriptions of heater components.

1-8. IDENTIFICATION AND TABULATED DATA.

a. Identification. The heater has four major identification plates. These are:

(1) The manufacturer's data/operating data plate (fig. 1-1) lists information regarding the model number, serial number, electrical characteristics, and heat output. It also provides brief operating instructions. The data plate is an integral part of the control box cover.

(2) The U.S. Government identification data plate (fig. 1-2) lists the heater's nomenclature national stock number, manufacturer's part number, manufacturer, contract number, assembly date, serial number, and weight.

(3) The circuit schematic data plate (fig. 1-2) shows the major components of the heater and how they are functionally interconnected. It is mounted on one side access door. Refer to figure 1-3 for a detailed view of the circuit schematic.

(4) The wiring diagram data plate (fig. 1-2) shows all of the electrical connections inside the heater. It is mounted on one side access door. Refer to figure 1-4 for a detailed view of the wiring diagram.

b. Tabulated Data. Tabulated data applicable to the space heater and its components is listed in Table 1-1.

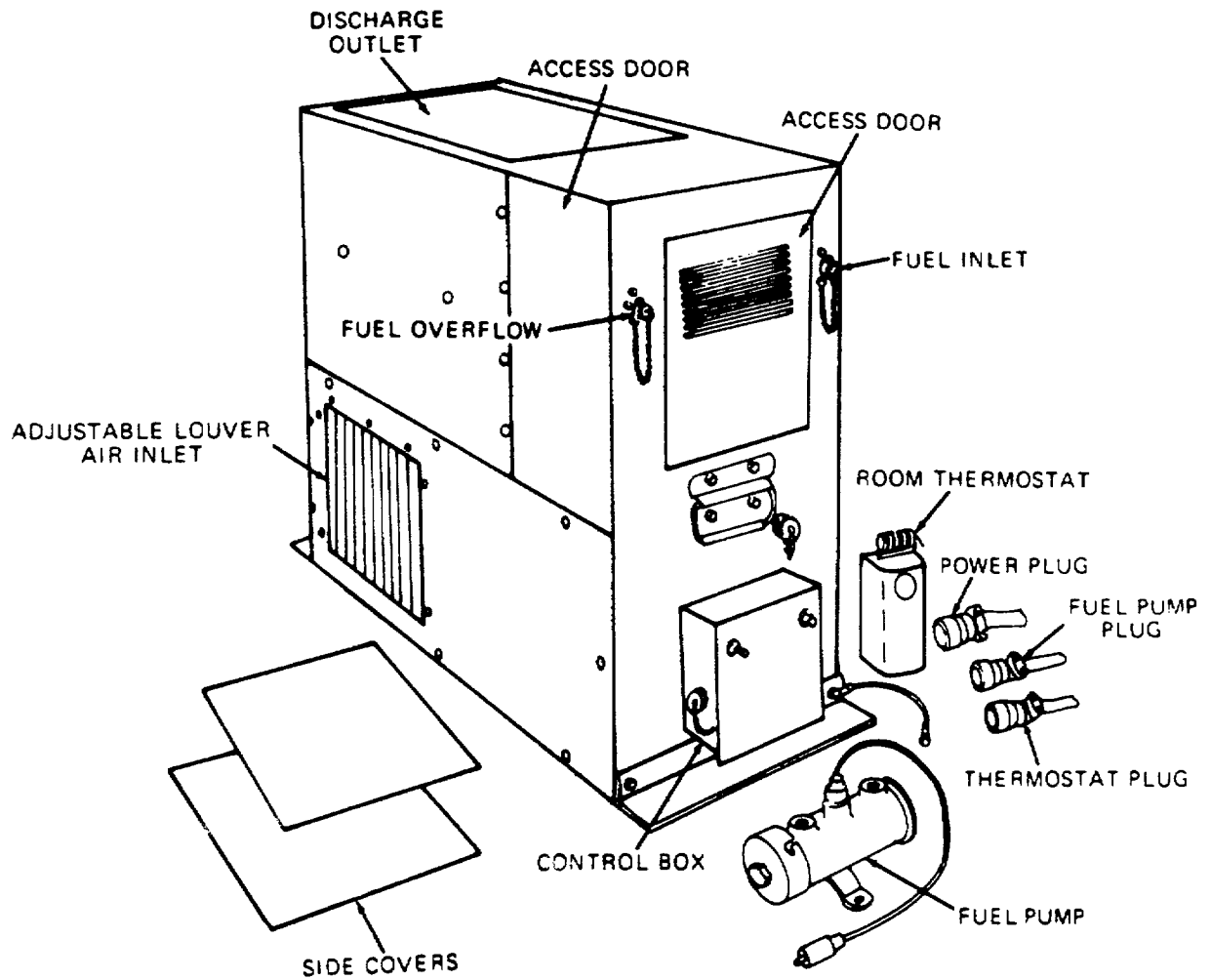

TS 4520-241-14/1-1.

Figure 1-1. Multifuel space heater, left front, three-quarter view.

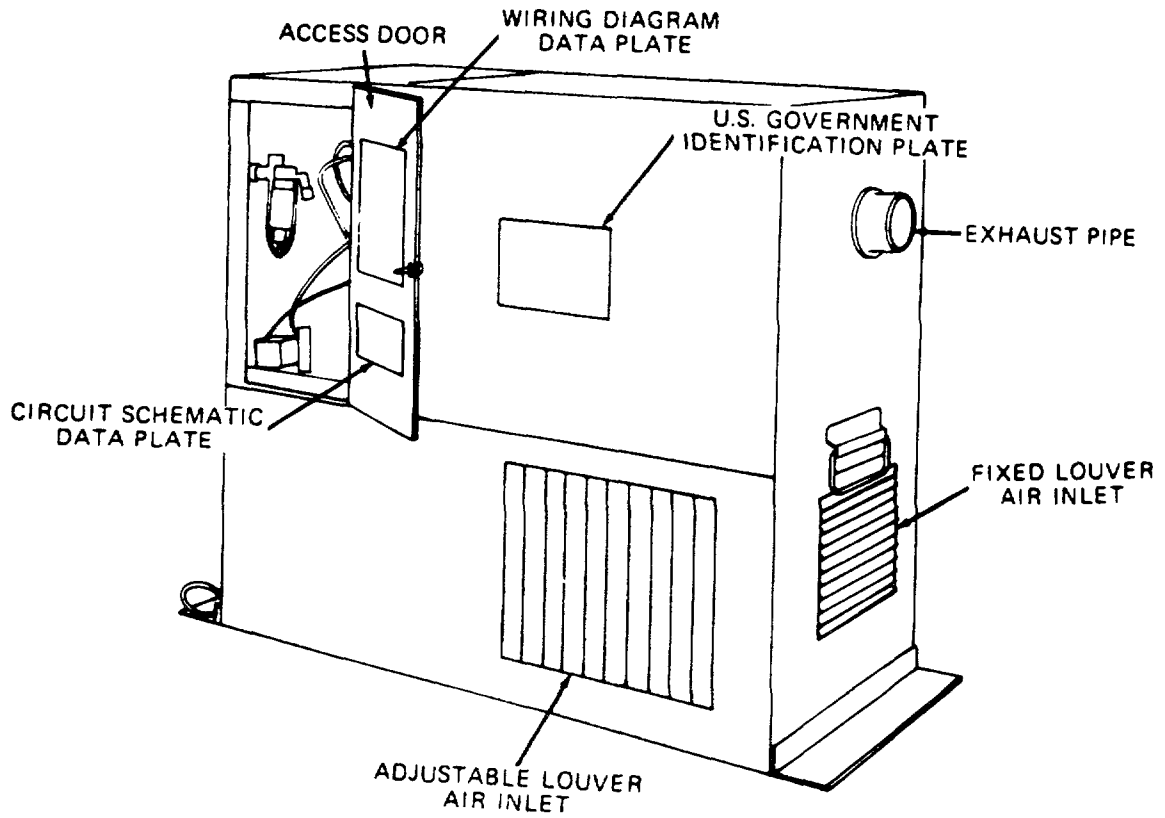

TS 4520-241-14/1-2

Figure 1-2. Multifuel space heater, right rear, three-quarter view.

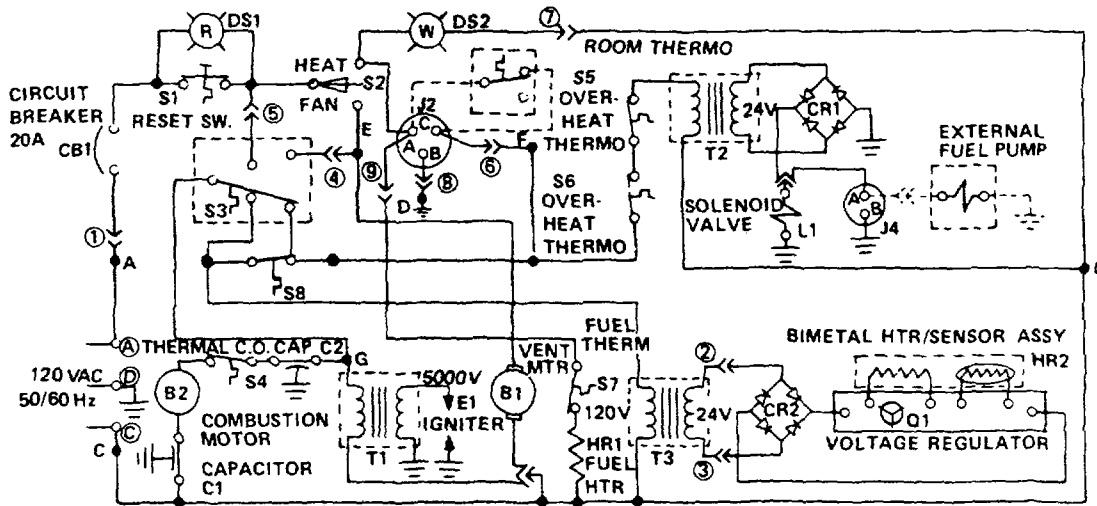

KEY	ITEM	KEY	ITEM	KEY	ITEM
B1	Ventilating motor	E1	Igniter	S2	Toggle switch (HEATER-OFF-FAN)
B2	Combustion motor	HR1	Fuel heater	S3	Flame switch
C1	Capacitor, interference suppression	HR2	Bimetal heater/sensor (Time delay)	S4	Thermal cutout switch
C2	Capacitor, interference suppression	J2	ROOM THERMO receptacle	S5	Overheat thermostat switch
CB1	Circuit breaker, 20 amps	J4	EXTERNAL FUEL PUMP RECEPTACLE	S6	Overheat thermostat switch
CR1	Rectifier (Fuel pump power supply)	L1	Solenoid valve	S7	Fuel thermostat switch
CR2	Rectifier (Time delay)	P1	Male plug (Control box) (see 2, fig. 4-15)	S8	Safety switch
DS1	Incandescent lamp (Red)	Q1	Transistor	T1	Ignition transformer
DS2	Incandescent lamp (White)	S1	Switch, SPST (RESET)	T2	Fuel pump power supply transformer
				T3	Time delay transformer

TS 4520-241-14/1-3

Figure 1-3. Circuit schematic diagram.

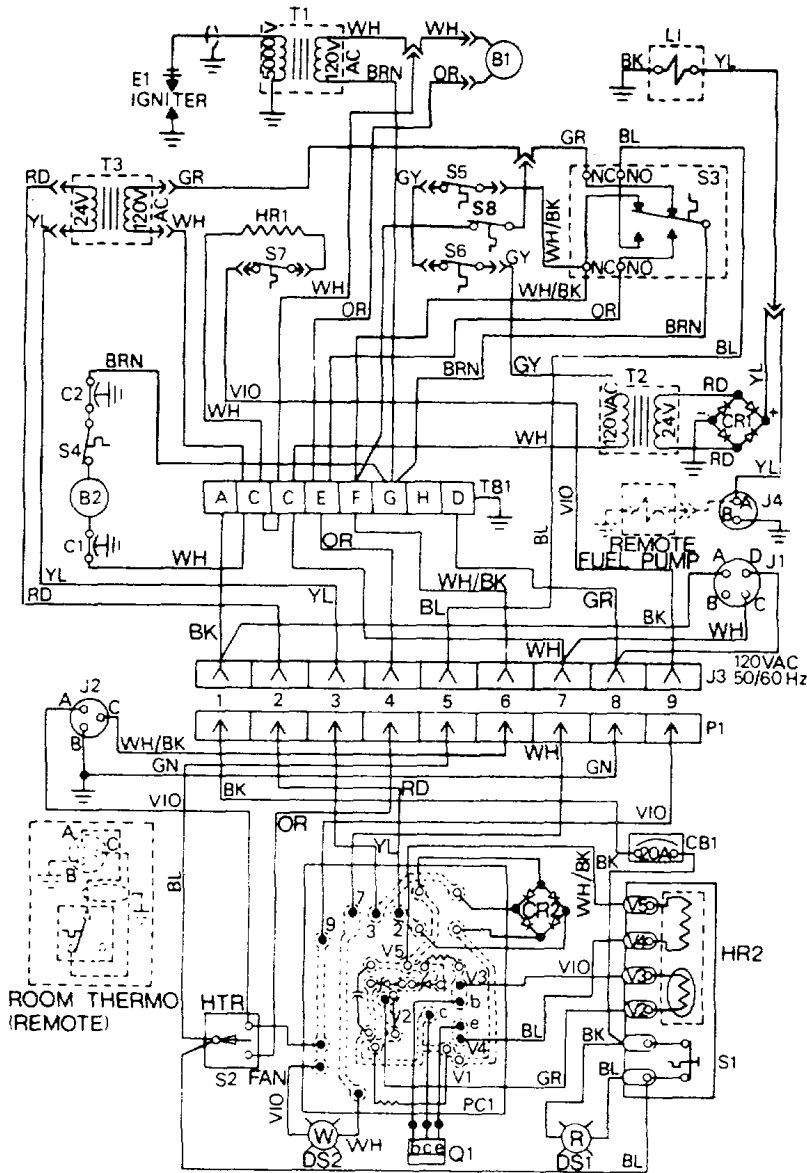

KEY TO DIAGRAM	
B1	Ventilating motor
B2	Combustion motor
C1	Capacitor, interference suppression
C2	Capacitor, interference suppression
CB1	Circuit breaker, 20 amps
CR1	Rectifier (Fuel pump power supply)
CR2	Rectifier (Time delay)
DS1	Incandescent lamp (Red)
DS2	Incandescent lamp (White)
E1	Igniter
HR1	Fuel heater
HR2	Bimetal heater/sensor (Time delay)
J1	POWER RECEPTACLE
J3	ROOM THERMO receptacle
J3	Female receptacle
J4	EXTERNAL FUEL PUMP RECEPTACLE
L1	Solenoid valve
PC1	PC board assembly
P1	Male plug (Control box)
Q1	Transistor
S1	Switch, SPST (RESET)
S2	Toggle switch (HEATER-OFF-FAN)
S3	Flame switch
S4	Thermal cutout switch
S5	Overheat thermostat switch
S6	Overheat thermostat switch
S7	Fuel thermostat switch
S8	Safety switch
TB1	Terminal board (Terminal strip)
T1	Ignition transformer
T2	Fuel pump power supply transformer
T3	Time delay transformer

Figure 1-4. Wiring diagram.

1-9. DIFFERENCES IN MODELS.

This publication covers only Model UH-68F Heater, serial numbers 15554 through 16018. No known differences exist for models in this serial number range.

Table 1-1. Tabulated Data

OPERATOR/CREW	
Manufacturer.....	Hunter Manufacturing Company
Model number.....	UH-68F
Voltage.....	120 VAC
Cycles.....	50/60 Hz
Current draw.....	7.0 amps
Btu output.....	60,000 per hour
Description.....	Heater, space, multifuel, with blower
Ventilation, air.....	675 CFM - 50 Hz 575 CFM - 60 Hz

ORGANIZATIONAL	
Overall dimensions and weight	
Height	21 3/16 in.
Width.....	10 7/8 inc.
Depth.....	24 1/8 in.
Weight	100 lb.
Circuit breaker	
Manufacturer.....	Mechanical Products, Inc.
Part number.....	MS25-244-20
Rating.....	20 amps
Fuel filter	
Manufacturer.....	Bendix Corporation
Part number.....	MS 51086
Float bowl assembly	
Manufacturer.....	Tillotson Manufacturing Company
Part number.....	.013440
Solenoid operator assembly	
Manufacturer.....	Hunter Manufacturing Company
Part number.....	1-168691
Cartridge heater assembly (fuel)	
Manufacturer.....	Hunter Manufacturing Company
Part number.....	2-168563

Table 1-1. Tabulated Data - Continued

ORGANIZATIONAL - continued

Fuel pump power supply	
Manufacturer	Hunter Manufacturing Company
Part number.....	1-168605
Ignition transformer assembly	
Manufacturer	Hunter Manufacturing Company
Part number.....	1-168629
Igniter assembly	
Manufacturer	Hunter Manufacturing Company
Part number.....	2-68681
Room thermostat	
Manufacturer	Hunter Manufacturing Company
Part number.....	68279
Range	35° to 95°F (1.7° to 35°C)
Pilot duty rating.....	125 volts AC

DIRECT SUPPORT AND GENERAL SUPPORT

Control box assembly	
Manufacturer	Hunter Manufacturing Company
Part number.....	1-168656
Circuitry.....	Printer circuits, transistor, wiring harness
Electrical wiring harness	
Manufacturer	Hunter Manufacturing Company
Part number.....	2-168664
Combustion motor	
Manufacturer	Hunter Manufacturing Company
Part number.....	1-168674
Operating power.....	120 VAC, 50/60 Hz
Horsepower.....	0.3
Duty cycle	Continuous
Suppression condenser, combustion motor	
Manufacturer	Cornell-Dubilier Electric Company
Part number.....	NFT2H47402TA
Capacitance	0.47 MFD, 200 VDC, 10 amps

Table 1-1. Tabulated Data - Continued

DIRECT SUPPORT AND GENERAL SUPPORT - Continued

Ventilating motor

Manufacturer	General Electric Company
Part number.....	5KH35KG981T
Operating power.....	115 VAC, 50/60 Hz
Horsepower.....	1/6
Overload reset.....	Automatic

CHAPTER 2
OPERATING INSTRUCTIONS

NOTE

If equipment fails to operate, refer to troubleshooting procedures in Chapter 3.

SECTION I. OPERATING PROCEDURES

2-1. GENERAL.

This section contains information and instructions for personnel responsible for operating the space heater. It includes information for starting and stopping the unit as well as basic heater operation.

2-2. CONTROLS AND RECEPTACLES.

Before operating the heater, familiarize yourself with the controls and receptacles on the unit. Refer to Table 2-1 and figures 2-1 and 2-2 for a description of these features.

Table 2-1. Controls and Receptacles

Fig. Item	and No.	Name	Operation and Use
2-1	1	EXTERNAL FUEL PUMP RECEPTACLE	Provides for the connection of an external fuel pump.
2-1	2	POWER RECEPTACLE	Provides a connection for 120 VAC power to the heater; includes radio interference filter.
2-1	3	ROOM THERMO receptacle	Provides for the connection of the remote thermostat which controls heater operation.
2-1	4	HEATER-OFF-FAN switch	Control starting and stopping of the heater. In the HEATER position the unit provides heated ventilating air. In the FAN position the unit provides unheated ventilating air. In the OFF position the unit will not function. When the heater is switched to OFF while running, it will cool down and then shut off.
2-1	5	White indicator light	Indicates that the unit is on and operating normally.
2-1	6	Red indicator light	Indicates that the unit has stopped because of ignition failure, lack of fuel, or combustion blower failure.
2-1	7	RESET switch	When pressed, switch resets heater circuits and the heater will repeat normal starting procedure.
2-1	8	FUEL OVERFLOW receptacle	When pressed, switch resets heater circuits and the heater will repeat normally starting procedure.
2-1	9	FUEL RECEPTACLE	Provides for connection of a fuel supply.
2-1	10	CIRCUIT BREAKER	Provides for power disconnect if a short circuit occurs.
2-1	11	Louver operating handle	Controls position of lovers in louvered panels.

Table 2-1. Controls and Receptacles - Continued

Fig. Item	and No.	Name	Operation and Use
2-2		Temperature adjustment knob	Provides a means of selecting the temperature which the heater is to maintain in the enclosure. Rotate the knob until desired temperature is aligned with index mark.

NOTE

The thermostat provides only an on-off control of the heater. Raising the thermostat setting does not increase the heat output of the heater per unit of operating time. It merely causes the heater to run longer to satisfy the heat demand. Setting the thermostat to the highest setting at startup does not increase the rate at which the desired temperature will be reached. To prevent temperature overshoot, set the thermostat only to the temperature desired for the enclosure.

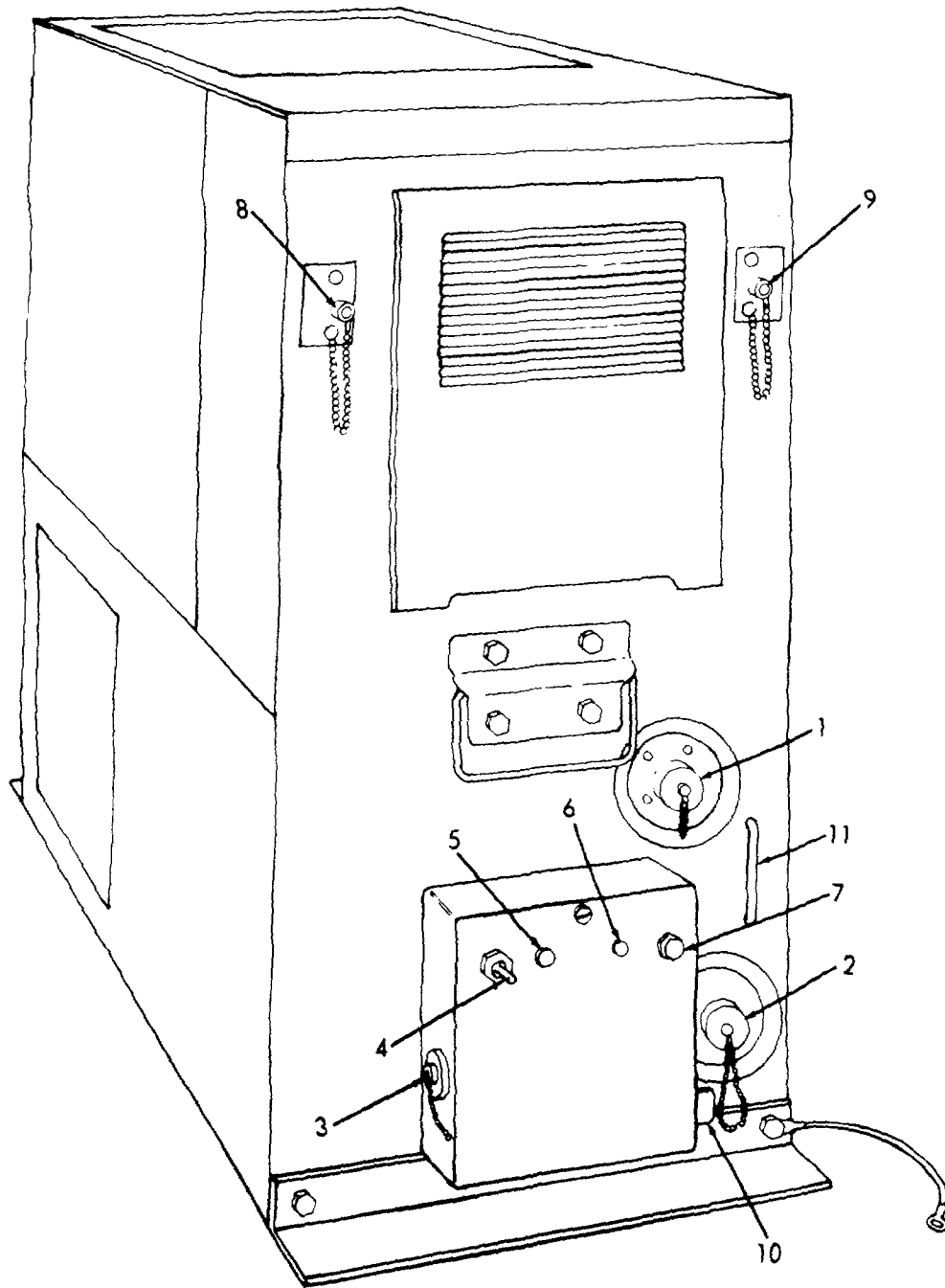

TS 4520-241-14/2-1

Figure 2-1. Controls and receptacles.

KEY to figure 2-1:

- | | |
|----------------------------------|-----------------------------|
| 1. EXTERNAL FUEL PUMP RECEPTACLE | 7. RESET switch |
| 2. POWER RECEPTACLE | 8. FUEL OVERFLOW receptacle |
| 3. ROOM THERMO receptacle | 9. FUEL RECEPTACLE |
| 4. HEATER-OFF-FAN switch | 10. CIRCUIT BREAKER |
| 5. White indicator light | 11. Louver operating handle |
| 6. Red indicator light | |

2-3. PREPARATION FOR STARTING.

- a. Check the fuel supply to see that it is adequate for the period of operation, and verify that the fuel supply valve is open.
- b. Check the external fuel pump and fuel lines for leakage or damage. Notify organizational maintenance if any leakage or damage is detected. Be sure the fuel pump is clean.
- c. Check that the power cable plug, room thermostat plug, and external fuel pump plug are fully inserted in mating receptacles with threaded swivels tightened.

2-4. OPERATION IN HEATER MODE.



Do not operate this heater in an enclosure unless exhaust gases are piped outside of the enclosure. The exhaust gases contain carbon monoxide, a colorless, odorless, deadly poisonous gas. Failure to provide proper elimination of the exhaust will cause severe illness or death.

- a. Check the setting of the temperature adjustment knob on the room thermostat (fig. 2-2). Adjust to the desired temperature.
- b. Place the HEATER-OFF-FAN switch (4, fig. 2-1) in the HEATER position. The white indicator light (5) will come on immediately. The heater will now operate under the control of the room thermostat. It will start when the thermostat calls for heat and stop when the selected temperature is reached.
- c. If the heater is extremely cold and combustion does not occur before flame failure shutdown, push the RESET button. Then open the front access door and pull out the choke knob on the carburetor. Hold it out until ignition occurs and you can hear combustion in the burner. The choke is only necessary when the heater is operating on diesel fuel or fuel oil.
- d. While the heater is running the ventilating motor circulates warm air from the discharge outlet.

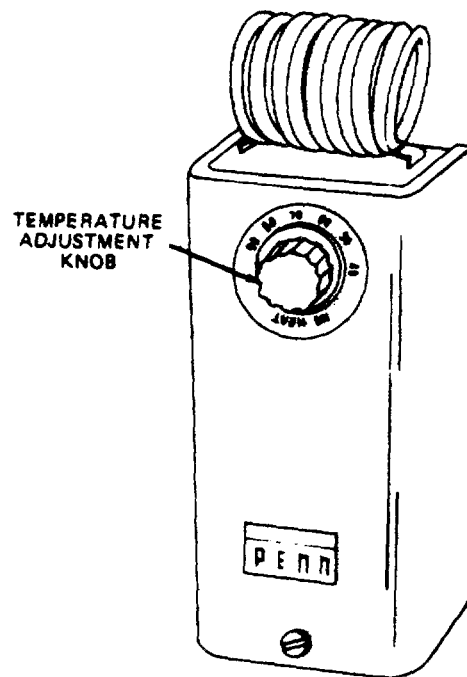

TS 4520-241-14/2-2

Figure 2-2. Room Thermostat.

e. If the heater stops shortly after starting, the red indicator light (6, fig. 2-1) will come on. Check the fuel supply and replenish if necessary. Allow 3 to 5 minutes for the heater to cool, then press RESET switch (7).

f. Open or close the louvers with the louver operating handle (11) so as to obtain maximum air intake for the ventilating motor.

2-5. OPERATION IN FAN MODE.

a. Place the HEATER-OFF-FAN switch in the FAN position.

b. The ventilating motor will come on immediately along with the white indicator light. The thermostat has no control. If the heater is still warm from operation, warm air will circulate, otherwise room air will just be recirculated.

2-6. SHUTOFF.

- a. To shut off the heater, turn the HEATER-OFF-FAN switch to OFF.



Do not disconnect the power cable from the power receptacle until the heater has completed its purge cycle.

- b. For several minutes after operation in the heater mode, the combustion and ventilating motors will continue to run. This is perfectly normal since the burner will continue to burn until all fuel has been purged. After the fuel is burned and the heater has cooled sufficiently, the heater will shut off.

SECTION II. OPERATION UNDER UNUSUAL CONDITIONS**2-7. OPERATION IN EXTREME COLD (BELOW 10°F) (-12.2°C).**

A thermostatically controlled fuel heater automatically heats the fuel when the temperature drops below $40 \pm 6^\circ \text{F}$ (1.1° to 7.8°C). This preheating of the fuel aids combustion and ignition during extremely cold conditions. No operating procedures are required for this fuel heater. You should take the following steps during extremely cold conditions:

- a. Keep the fuel tank full to prevent condensation of moisture in the tank.
- b. Clean snow and ice from fuel tank filler to prevent them from entering fuel tank, causing freezing in fuel lines.
- c. Use the choke on the carburetor for starting (Diesel fuel or fuel oil only).

2-8. OPERATION AT HIGH ALTITUDES.

- a. The heater is designed to operate at elevations up to 10,000 feet above sea level without special service or adjustment.

- b. At 10,000-foot altitude, heat output may be reduced approximately 15 percent. This is a normal condition which cannot be prevented, but optimum performance can be obtained by following all service instructions carefully.

2-9. OPERATION UNDER RAINY OR HUMID CONDITIONS.

- a. Wipe all accessible exposed areas frequently.
- b. Paint all chipped or scratched surfaces to prevent rust.
- c. Cover the heater when not in use.

2-10. OPERATION UNDER SANDY CONDITIONS.

- a. Keep side covers on when not in use.
- b. Keep access door on at all times (except when inspecting heater).
- c. Keep sand and grit away from heater.
- d. Check for fuel leaks. (Do not operate heater with a fuel leak.)

CHAPTER 3

OPERATOR/CREW MAINTENANCE INSTRUCTIONS

SECTION I. LUBRICATION INSTRUCTIONS

No lubrication is required.

SECTION II. PREVENTIVE MAINTENANCE CHECKS AND SERVICES

3-1. GENERAL.

To ensure that the space heater is ready for operation at all times, it must be inspected systematically so that defects may be discovered and corrected before they result in serious damage or failure. The necessary preventive maintenance services to be performed are listed and described in Table 3-1. Defects discovered during operation of the unit shall be noted for future correction, to be made as soon as operation has ceased. Stop operation immediately if a deficiency is noticed which would damage the equipment if operation were continued. All deficiencies and shortcomings will be recorded, together with the corrective action taken, on DA Form 2404 (Equipment Inspection and Maintenance Worksheet) at the earliest possible opportunity.

3-2. PREVENTIVE MAINTENANCE CHECKS AND SERVICES (PMCS).**NOTE**

This heater does not require any lubrication. All bearings are permanently lubricated.

Refer to Table 3-1 for a tabulated listing of preventive maintenance checks and services which you must perform. The item numbers are listed consecutively and indicate the sequence of minimum requirements. The time interval "daily" should be regarded as the beginning of each duty shift.

3-3. SERVICING STANDBY HEATERS.

- a. Heaters on standby which have the fuel connections and power connections intact must be run periodically to prevent fuel in the lines from losing volatility. Fuel with low volatility will make heater starting difficult or impossible.
- b. Every two weeks, run standby heaters long enough to replace residual fuel in the fuel system of each heater to ensure that the heaters will start when they are needed.

Table 3-1. Operator/Crew Preventive Maintenance Checks and Services

NOTE

Within designated interval, these checks are to be performed in the order listed.

B - Before

Item No.	Interval B	Item To be Inspected	Procedures Check for and have repaired or adjusted as necessary	Equipment is Not Ready/ Available if:
1	•	Space heater	<p style="text-align: center;">NOTE</p> <p>Keep heater clean by wiping with a clean cloth. Ensure that air inlet and discharge outlet are free of obstruction.</p> <p>Make the following walk around checks:</p> <p>a. Check for fuel leakage in or around heater unit.</p> <p>b. Check that the external cable connections are fully inserted in mating receptacles with swivels tight.</p> <p style="text-align: center;">NOTE</p> <p>During starting and operation, check for any unusual noises or vibration. Check for improper or excessive cycling, smoking exhaust, and improper combustion. Check for fuel leakage, loose hardware, or any indication of a failing or defective component. If suspected, notify organizational maintenance.</p>	Any fuel leakage is found.

SECTION III. TROUBLESHOOTING

3-4. GENERAL.

a. This section contains troubleshooting information for locating and correcting most of the operating problems which may develop in the space heater. Each malfunction is followed by a list of tests or inspections which will help you to determine probable causes and corrective actions to take. You should perform the tests/inspections and corrective actions in the order listed.

b. This manual cannot list all malfunctions that may occur, nor all tests or inspections and corrective action. If a malfunction is not listed, or is not corrected by listed corrective actions, notify your supervisor.

3-5. OPERATOR/CREW TROUBLESHOOTING CHART.

Refer to table 3-2 for troubleshooting which is allocated to the operator/crew maintenance level.

NOTE

Before you use this table, be sure you have performed all applicable operating checks.

Table 3-2. Operator/Crew Troubleshooting

MALFUNCTION

TESTING OR INSPECTION

CORRECTIVE ACTION

1. HEATER FAILS TO START (NO FLAME, NO VENTILATING AIR).

Step 1. Check that power is applied to heater.

Connect heater to a source of 120 VAC power. Ensure that power is connected to the POWER receptacle.

Step 2. Check that HEATER-OFF-FAN switch is in either FAN or HEATER position.

Step 3. Check room thermostat setting.

Thermostat setting must be higher than ambient temperature of enclosure to start heater operation.

Table 3-2. Operator/Crew Troubleshooting - Continued

MALFUNCTION**TESTING OR INSPECTION****CORRECTIVE ACTION**

Step 4. Check RESET switch.

Press RESET switch to reset beater circuit. Start heater in normal manner.

2. HEATER FAILS TO START (NO HEAT; COMBUSTION MOTOR RUNS FOR A SHORT TIME, THEN STOPS).

Step 1. Check that fuel tank contains fuel.

Replenish fuel supply.

Step 2. Check that fuel supply has recently been replenished and that it contains no visible contaminants.

Replace fuel in lines and tank if it has become old or contaminated.

3. HEATER OVERHEATS (OVERHEAT THERMOSTAT CUTS OFF FUEL FLOW)

Check for airflow restrictions.

Clear area of obstructions to permit free passage of air into and out of heater.

4. HEATER BACKFIRES

Check for correct fuel. If the fuel has a high volatility, heat from the heat exchanger can create bubbles of fuel vapor in the carburetor. Typically, this is a problem with certain gasolines.

Change type of fuel used, if possible.

SECTION IV. MAINTENANCE PROCEDURES**3-6. MAINTENANCE OF FUEL SUPPLY.**

a. The heater will operate satisfactorily on any gasoline conforming to Specification MIL-G-3056, VV-G-76, or any other gasoline (leaded or aromatic) of up to 100-octane grade. It will also burn diesel fuel which conforms to Specification VV-F-800, Class DF-1, DF-2, or DF-A. Refer to Appendix D for specific fuel used.

b. During operation in extremely cold temperatures it is important to keep the fuel tank full to prevent condensation in the tank. Moisture in the tank can enter the heater fuel system and interfere with proper combustion, or can freeze in the fuel line, stopping the flow of fuel.

3-7. MAINTENANCE OF FUEL LINES.

Check that the fuel lines and fittings between the fuel supply and the heater are not kinked, leaking, or otherwise damaged. Report leaks and other damage to organizational maintenance.

CHAPTER 4

ORGANIZATIONAL MAINTENANCE INSTRUCTIONS

SECTION I. SERVICE UPON RECEIPT OF MATERIEL

4-1. INSPECTING AND SERVICING THE EQUIPMENT.

- a. Inspect the heater for lost parts or for damage which may have occurred during shipment.
- b. Check the controls for free operation.
- c. Inspect for loose or missing hardware.
- d. Inspect the room thermostat for a broken or loose element.
- e. Inspect all tubing, lines, and fittings to see that they are secure and free of breaks, kinks, and other damage.
- f. Correct all deficiencies or report them to direct support maintenance.

4-2. INSTALLATION OF SEPARATELY PACKED COMPONENTS.

The room thermostat, the side case covers, and three plugs are packed separately. The three plugs are used for connection of a fuel pump (two pins), the thermostat (three pins), and 120 volt AC power (four pins). The mating receptacles for these plugs are clearly labeled. The side case covers are used only when the side louvers will not be operating, or when the heater is in storage.

4-3. INSTALLATION INSTRUCTIONS.**WARNING**

Do not locate the heater where expelled exhaust gases can be recirculated into inlet air openings of the heated space. Inhalation of exhaust fumes can cause serious illness or death.

a. Location.

(1) Position the heater so that the exhaust can be vented to the outside with a short, direct run. Fresh air must be pulled in through either the side louvers or return air opening, or both. If more efficient heat distribution can be obtained by mounting the heater horizontally or vertically, make modifications as required (see figure 4-2).

(2) The heater is equipped with two angle brackets for base mounting. They are drilled for 5/16 inch (8 mm) bolts or lag screws. Base mounting dimensions are shown in figure 4-1.

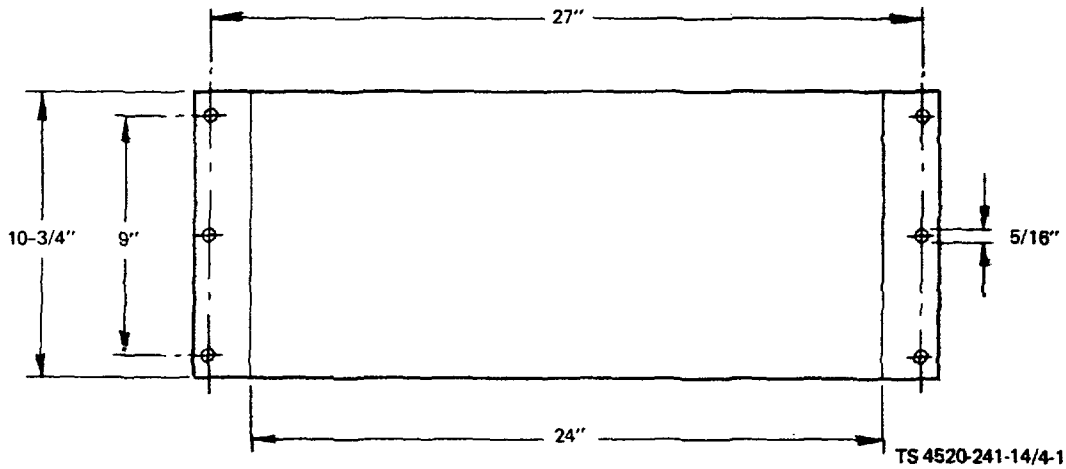

Figure 4-1. Base mounting dimensions.

b. Installation.

- (1) Mount the room thermostat in an upright position on an inside or insulated wall in the area to be heated.

NOTE

Do not install the room thermostat in line with either the heater air inlet or discharge, in a drafty area, or on an outside wall.

- (2) Remove the thermostat cover and attach a 16-gage, 3-wire (red, black, green) electrical cable per MIL-W-16878D. The cable must be long enough to connect the thermostat to the heater. Secure the ground lead to one of the thermostat mounting screws, and connect the other two wires (red and black) to the two terminals on the thermostat switch. Attach the other end of the cable to the three-pin room thermostat plug (which is packaged separately). Be sure to attach the ground wire of the cable to the ground terminal (pin B) of the plug. Connect the assembled plug to the ROOM THERMO receptacle on the side of the heater control box.

WARNING

Do not connect the power cable to a 120 VAC, 50/60 Hz electrical source until the power plug has been properly installed on the power cable.

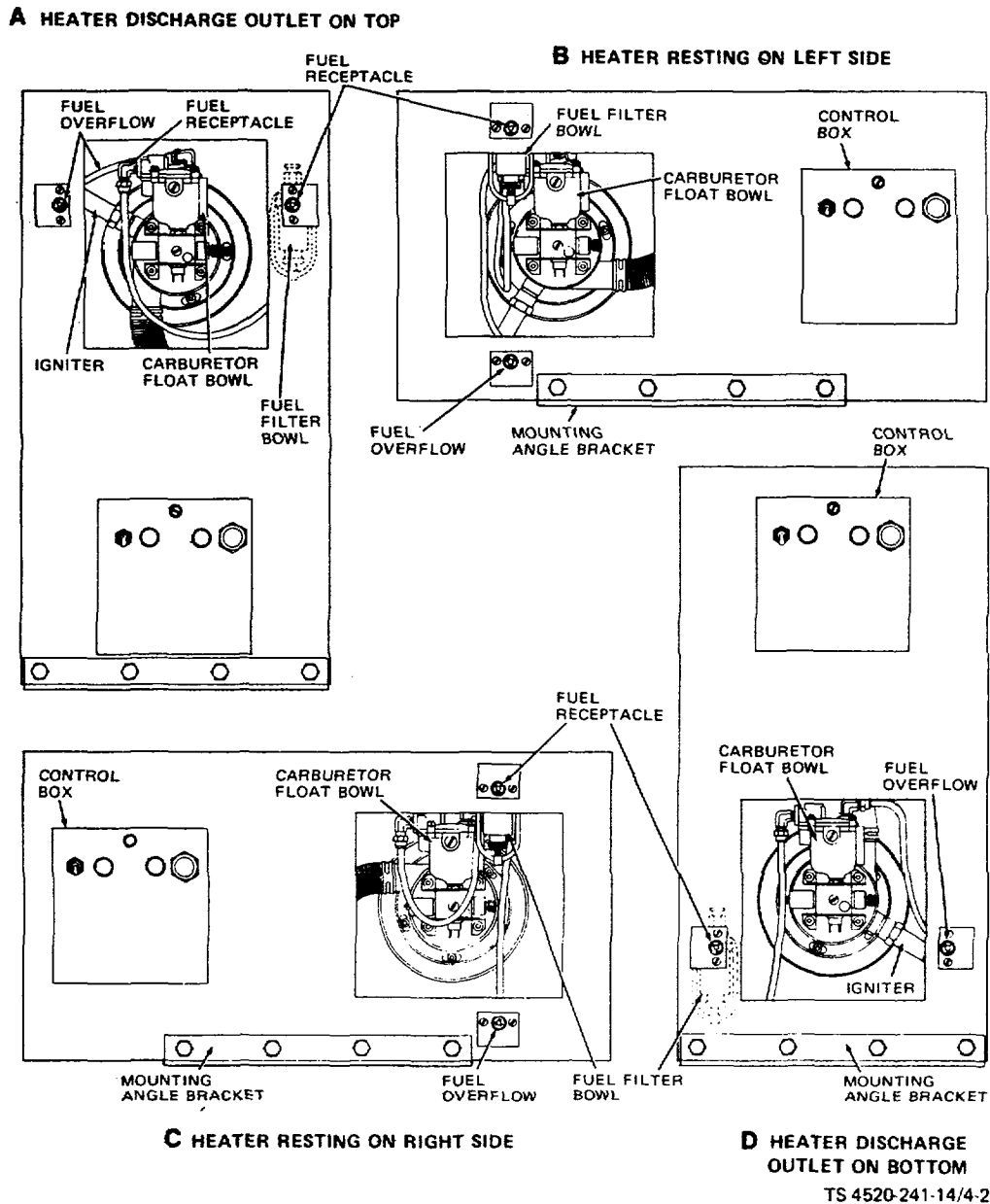

Figure 4-2. Modification required for various mounting positions.

(3) Provide a 3-wire, 12-gage cable from the four-pin power plug to the 120 volt, 50/60 Hz power source. Connect wires as follows:

- (a) Pin A to line L1
- (b) Pin C to line L2
- (c) Pin D to ground
- (d) Pin B is not used

(4) Attach the other end of the cable to a power source, making sure the ground lead is attached to the power source ground. With the HEATER-OFF-FAN switch in the OFF position, insert the power plug into the POWER

RECEPTACLE on the front of the heater.

(5) Connect the fuel supply line to the FUEL RECEPTACLE which has a 7/16-20 UNF-2A male thread. Tighten securely. Connect a similar line for fuel overflow to the FUEL OVERFLOW fitting and drain to a safe area in case of carburetor malfunction.

(6) This heater requires an external fuel pump. Use a 2-wire, 16-gage cable to connect the fuel pump to the space heater. Connect the cable to the two-pin fuel pump plug, and plug into the EXTERNAL FUEL PUMP RECEPTACLE on the front of the heater. A single 16-gage wire will be sufficient if the pump has a grounded body connection.

WARNING

During operation, the exhaust pipe becomes hot enough to cause combustion of wood or other flammable building materials. Provide adequate fire-proofing insulation between the exhaust pipe and wall to prevent fire.

(7) Connect the exhaust line to the exhaust fitting at the rear of the heater. Extend the line outside of the enclosed area. Do not use more than 4 2-inch elbows, or more than 6 feet of pipe, to make connections. More elbows or more pipe will restrict the exhaust flow and reduce heater efficiency.

4-4. EQUIPMENT CONVERSION.

a. General. The heater can also be operated horizontally on either its right or left side, or completely inverted from the position shown in this manual. The necessary conversion steps are described below and illustrated in figure 4-2.

b. Right Side Mounting.

(1) Disconnect the fuel line from the carburetor. Remove the four machine screws and lock washers which secure the carburetor to the burner head. Rotate the carburetor 90 degrees so that the float bowl is vertical, and reinstall the screws. Reconnect the fuel line to the carburetor.

(2) Remove the screws that secure the assembled fuel receptacle and fuel filter and the fuel overflow receptacle to the front of the heater case. Reverse the positions of these receptacles as well as their identification plates.

(3) After the fuel receptacle is secured, rotate the fuel filter so that the bowl is hanging below the filter body.

(4) Adjust the louver control handle to open or close the louvers as required.

(5) Remove the cap screws and washers which fasten the mounting brackets to the heater case. Reposition them to permit mounting of the heater with 5/16 inch (8 mm) bolts or lag screws.

(6) Open the control box, and unlock the two studs which secure the control box to the heater case. Rotate the control box so that the printing on the control box cover is upright, and tighten the two studs. Close the control box.

c. Left Side Mounting.

(1) Disconnect the fuel line from the carburetor. Remove the four machine screws and lock washers which secure the carburetor to the burner head. Rotate the carburetor 90 degrees so that the float bowl is vertical, and reinstall the screws. Reconnect the fuel line to the carburetor.

(2) Rotate the fuel filter so that the bowl is hanging below the filter body.

(3) Adjust the louver control handle to open or close the louvers as required.

(4) Remove the cap screws and washers which fasten the mounting brackets to the heater case. Reposition them to permit mounting of the heater with 5/16 inch (8 mm) bolts or lag screws.

(5) Open the control box, and unlock the two studs which secure the control box to the heater case. Rotate the control box so that the printing on the control box cover is upright, and tighten the two studs. Close the control box.

d. Inverted Mounting.

(1) Disconnect the fuel line from the carburetor. Remove the four machine screws and lock washers which secure the carburetor to the burner head. Rotate the carburetor 180 degrees so that the float bowl is vertical, and reinstall the screws. Reconnect the fuel line to the carburetor.

(2) Remove the screws that secure the assembled fuel receptacle, and fuel filter to the front of the heater case. Invert the position of the receptacle and the fuel filter assembly.

(3) After the fuel receptacle is secured, make sure that the fuel filter bowl is hanging below the filter body.

(4) Adjust the louver control handle to open or close the louvers as required. If both louver openings are obstructed, remove the bottom plate to provide an air inlet.

(5) Remove the cap screws and washers which fasten the mounting brackets to the heater case. Reposition them to permit mounting of the heater with 5/16 inch (8 mm) bolts or lag screws.

(6) Open the control box, and unlock the two studs which secure the control box to the heater case. Rotate the control box so that the printing on the control box cover is upright, and tighten the two studs. Close the control box.

e. Side Covers. The side covers, which are packed separately, may be used to cover the louvers when they are not needed as air inlets. Remove the four screws from the heater side panel, install the cover, and replace the screws.

4-5. INITIAL CHECKOUT AND ADJUSTMENT.

After installation, check heater operation as follows:

a. Move the HEATER-OFF-FAN switch to FAN. The white indicator should not light and the ventilating blower motor must start immediately to expel air from the heater. Check for air flow, and ensure that there are no obstructions in the path of the discharged air.

b. Set the thermostat knob to less than ambient temperature. Move the HEATER-OFF-FAN switch to HEATER. The ventilating blower must stop, the white indicator light must be on, and the red indicator light must be off.

c. Start heater operation by setting the thermostat knob to a temperature above ambient temperature. The combustion motor should start immediately, but not the ventilating motor so that there is no air flow in the enclosure. The external fuel pump should start simultaneously, and there may be a slight buzzing or hissing from the ignition system.

d. Unless the ambient temperature is extremely low, the heater should ignite within a minute, as evidenced by the starting of the ventilating motor. At low ambient temperatures when diesel fuel or fuel oil is used; the burner may not ignite within the time allowed by the time delay assembly, and the red indicator will light. If this occurs, wait a few minutes then push the RESET button on the control box. Open the front access door and pull out the choke knob on the carburetor. Hold it out until ignition occurs and you can hear combustion in the burner.

e. After allowing a few minutes for the heater to warm up, check the exhaust for smoke, and check for erratic operation. If either condition occurs, adjust the fuel needle as follows:

NOTE

Adjustment can be made directly through the front access door. There is no need to remove any panels.

(1) Turn the fuel needle (fig. 4-3) clockwise gently until it is seated in the carburetor body.

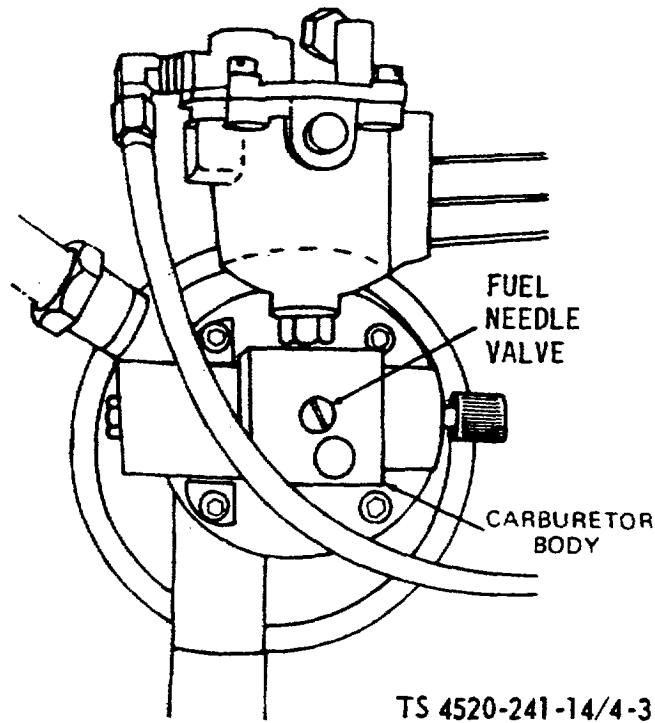

Figure 4-3. Fuel Needle Adjustment.

CAUTION

Do not force the fuel needle. This may damage the fuel orifice and make correct adjustment difficult or impossible.

(2) Turn the fuel needle valve counterclockwise one full turn, then continue in 1/8 turn increments. After each increment inspect the exhaust. The fuel flow should be increased until there is no odor of unburned fuel or any smoke.

(3) In low ambient temperatures it may be necessary to increase the fuel flow to achieve smooth burner operation.

f. Check that the beater shuts off when the temperature in the enclosure has reached the temperature set on the thermostat. If conditions permit, check that the heater cycles under control of the room thermostat.

g. Stop the heater by moving the HEATER-OFF-FAN switch to OFF. The white indicator light will go out immediately. If the heater is burning when the switch is moved to OFF, the burner flame will go out immediately, but the ventilating and combustion blower motors will continue to run until all heat is purged from the burner. When the heat exchanger has cooled, both motors will stop.

- h. Refer to Table 4-2, Troubleshooting, if the heater fails to operate in this manner.

SECTION II. MOVEMENT TO A NEW WORKSITE

4-6. DISMANTLING FOR MOVEMENT.

- a. Disconnect the fuel line from the fuel inlet bulkhead fitting. Cover the fitting with its seal cap.
- b. Disconnect the external fuel pump cable from the external fuel pump receptacle. Cover the receptacle with its dust cap.
- c. Operate the heater until all fuel is expended, the purge cycle is complete, and the heater shuts down.
- d. Disconnect the power cable from the power receptacle, and cover the receptacle with its dust cap.

WARNING

There may be fuel in the overflow line. Provide a container to drain this line so the flammable fuel will not be spilled.

- e. Disconnect the fuel overflow line from the fuel overflow bulkhead fitting. Cover the fitting with the seal cap on the chain.
- f. Disconnect the room thermostat cable from the room thermostat receptacle. Cover the receptacle with its dust cap.
- g. Disconnect the heater exhaust line.
- h. Remove the bolt securing the heater to the base or floor.
- i. Remove, drain, and reinstall the bowl on the fuel filter.
- j. Remove the plug from the *carburetor* float bowl, tip the heater forward, and drain the remaining fuel into a small container.
- k. Close the side louvers and install the side case covers.
- l. Install the bottom plate, if it has been removed for operation.

4-7. REINSTALLATION AFTER MOVEMENT.

Refer to paragraph 4-3 for installation instructions.

SECTION III. REPAIR PARTS, SPECIAL TOOLS, AND EQUIPMENT**4-8. SPECIAL TOOLS AND EQUIPMENT.**

No special tools or equipment are required.

4-9. MAINTENANCE REPAIR PARTS.

Repair parts and equipment are listed and illustrated in TM-5-4520-241-24P, Repair Parts and Special Tools List.

SECTION IV. PREVENTIVE MAINTENANCE CHECKS AND SERVICES**4-10. GENERAL.**

This section lists the preventive maintenance checks and services which shall be performed on a quarterly basis by organizational maintenance personnel. It includes and expands upon the preventive maintenance services performed by operator/crew maintenance, and includes additional services which are allocated to organizational maintenance.

4-11. PREVENTIVE MAINTENANCE CHECKS AND SERVICES.

Consult Table 4-1 for a listing of the preventive maintenance checks and services which are allocated to organizational maintenance.

Table 4-1. Organizational Preventive Maintenance Checks and Services

Q - Quarterly

Item No.	Interval Q	Item to be Inspected	Procedures
			<p style="text-align: center;"><u>WARNING</u></p> <p>Death or serious injury could result if electrical precautions are not taken when maintaining this equipment. Disconnect power plug from receptacle before performing any maintenance checks or services.</p> <p style="text-align: center;"><u>WARNING</u></p> <p>Death or serious injury could result if repeated and/or prolonged breathing and/or liquid skin contact of cleaning solvent P-D-680. Use cleaning solvent in a well ventilated area. Do not use near flame or excessive heat. The flash point of this solvent is 100°F to 138°F (38°C to 59°C).</p>
1	•	Space Heater Assembly	Open heater doors and remove side panels. Clean heater inside and outside using a vacuum and clean cloth. Wipe away oil and dirt using cleaning solvent P-D-680, Type II. Check for loose, missing, or damaged hardware and components.
2	•	Electrical System	Check electrical components and wiring for evidence of overheating, loose connections, loose mounting hardware, and other damage.
3	•	Fuel System	Check fuel system for leakage, damage, and loose hardware. Remove and clean sediment bowl and filter element. Replace a defective filter element.
4	•	Burner Head	Check that the burner head is securely mounted to the end of heat exchanger. Tighten attaching screws if necessary.

Pages 4-11 thru 4-18 deleted

SECTION V. TROUBLESHOOTING**4-12. GENERAL.**

a. This section contains troubleshooting information for locating and correcting most of the operating troubles which may develop in the space heater. Each malfunction is followed by a list of tests or inspections which will help you to determine probable causes and corrective actions to take. Perform the test/inspections and corrective actions in the order listed.

b. This manual cannot list all malfunctions that may occur, nor all tests or inspections and corrective actions. If a malfunction is not listed or is not corrected by listed corrective actions, notify your supervisor.

c. Only those functions which are solely within the scope of organizational maintenance are listed.

4-13. ORGANIZATIONAL MAINTENANCE TROUBLESHOOTING CHART.

Refer to Table 4-2 for troubleshooting which is allocated to organizational maintenance levels.

NOTE

Before you use this table, be sure you have performed all applicable operating checks.

Table 4-2. Organizational Maintenance Troubleshooting

MALFUNCTION
TESTING OR INSPECTION
CORRECTIVE ACTION

WARNING

This space heater contains dangerous voltages which can cause severe electrical shock. Be extremely careful when making voltage measurements or other checks with the heater connected to the power source during troubleshooting. Always disconnect the power cable plug before making any continuity test.

1. BOTH INDICATOR LIGHTS FAIL TO LIGHT WHEN HEATER-OFF-FAN SWITCH IS TURNED TO HEATER.
 - Step 1. Check for tripped circuit breaker.
 - Press circuit breaker reset button.
 - Step 2. Check power source for 120 VAC.
 - Restore circuit or repair power source.
 - Step 3. Check for power to heater. Remove control box and disconnect male plug. Check for 120 VAC with voltmeter at sockets 1 and 7 on exposed 9-socket receptacle.
 - Check power cable and power receptacle as indicated below.
 - Step 4. Disconnect power cable from source and heater. Use test light or ohmmeter to check for continuity from end to end.
 - Disassemble plug and tighten connections. Replace or repair cable if tightening connections fails to correct the defect.
 - Step 5. Check for defective power receptacle (filter and receptacle assembly). With power cable disconnected from heater, use test light or ohmmeter to check continuity from receptacle pins to solder terminals on back of receptacle filter.

Table 4-2. Organizational Maintenance Troubleshooting - Continued

MALFUNCTION**TESTING OR INSPECTION****CORRECTIVE ACTION**

1 - Continued

If connection is open, filter and receptacle assembly is defective. Remove attaching hardware, and unsolder wires at back of receptacle. Install new receptacle and resolder wires.

- Step 6. Check for defective HEATER-OFF-FAN switch. Disconnect power plug. Open control box and check continuity between center terminals and terminals at HEATER and FAN ends with toggle in respective positions.

Replace switch if it fails to make contact. Unsolder wires, remove hex nut from front of control box cover, and remove switch. Install new switch and resolder wires.

2. WHITE INDICATOR LIGHT COMES ON, RED INDICATOR LIGHT STAYS OFF, BUT NEITHER MOTOR RUNS AND THERE IS NO COMBUSTION.

- Step 1. Check room thermostat setting.

Set room thermostat to above ambient temperature and recheck.

- Step 2. Check for power to ROOM THERMO receptacle. Unplug thermostat cable at control box. Turn on power and check for 120 volts at pins A and B in ROOM THERMO receptacle.

Disconnect power plug and open control box. During test above, no voltage at receptacle indicates bad connection between switch and receptacle. Resolder loose connection or replace broken wire.

- Step 3. Check room thermostat cable. Plug cable into control box. Turn temperature adjustment knob to a high setting and turn on switch. Remove cover from room thermostat and check for 120 volts across switch terminals inside thermostat.

No voltage at thermostat switch terminals indicates defective cable or plug. Disconnect cable from control box and disassemble plug. Tighten connections or repair cable between plug and

Table 4-2. Organizational Maintenance Troubleshooting - Continued

MALFUNCTION	TESTING OR INSPECTION	CORRECTIVE ACTION
2 - Continued	room thermostat.	<p>Step 4. Check for defective room thermostat. Disconnect room thermostat cable from control box. Check continuity across thermostat. Remove cover from room thermostat and check continuity across switch terminals while rotating thermostat knob.</p>
		<p>Replace thermostat if switch fails to open and close in response to rotating knob and rising and falling temperature.</p>
3. VENTILATING MOTOR FAILS TO STOP AFTER HEATER HAS COOLED.		<p>Step 1. Check flame switch. Open access doors with power plug connected. While heat exchanger is hot, and switch is OFF, check voltage at terminals C and G on terminal strip near carburetor.</p>
		<p>If 120 volts is present on terminals, flame switch is defective. Disconnect power plug. Disconnect wires at flame switch, (8, fig. 4-4). It is normally possible to remove the flame switch without removing the carburetor or burner head. Remove screws (1), washers (2 and 3), and pull out assembled switch and bracket (4 through 8). Remove screws (4) and washers (5 and 6) securing flame switch (8) to mounting base (7). Pull off defective switch. No repair is possible. Install a new switch by reversing the removal procedure. Be sure tip of flame switch probe engages bracket on heat exchanger.</p>

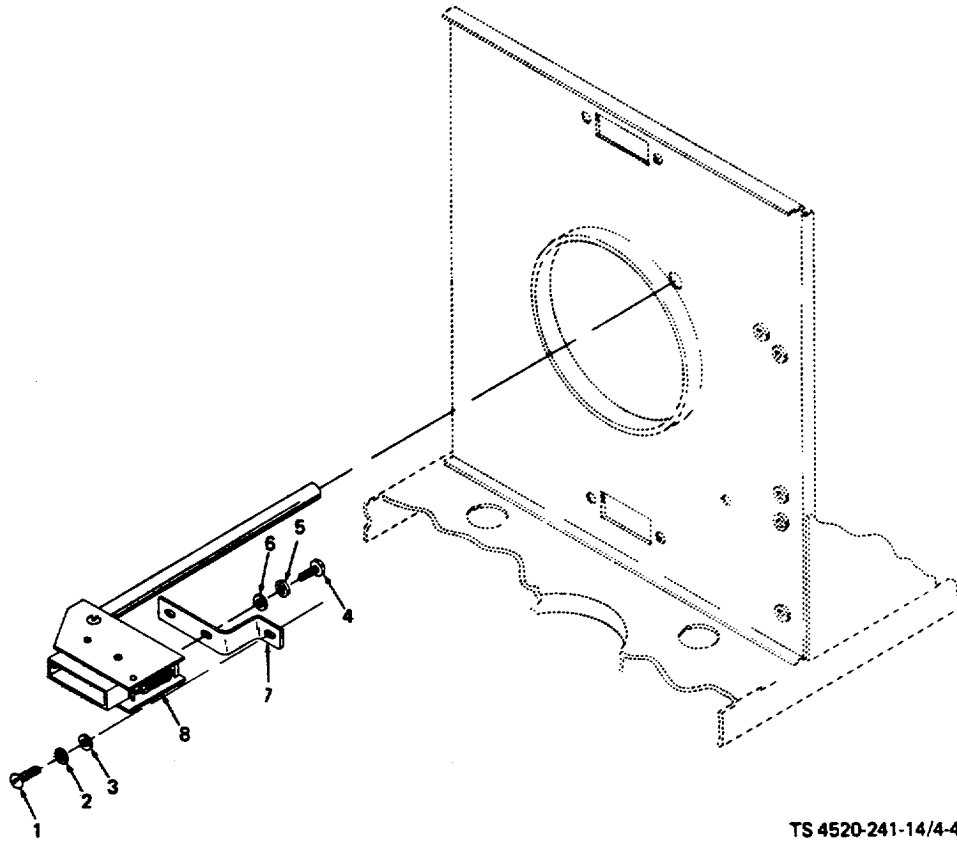

TS 4520-241-14/4-4

- | | |
|----------------|------------------|
| 1. Screw | 5. Lock washer |
| 2. Lock washer | 6. Flat washer |
| 3. Flat washer | 7. Mounting base |
| 4. Screw | 8. Flame switch |

Figure 4-4. Flame switch mounting.

Table 4-2. Organizational Maintenance Troubleshooting - Continued

MALFUNCTION	TESTING OR INSPECTION	CORRECTIVE ACTION
4. HEATER FAILS TO IGNITE, AND RED INDICATOR LIGHT COMES ON.		
	Step 1. Check that fuel supply is adequate and external fuel shutoff is open.	Refill fuel supply tank or open valve.
	Step 2. Check for clogged fuel filter. Disconnect power plug to heater. Open access doors, and loosen knurled nut at bottom of fuel filter. Swing aside the bail and pull off bowl and gasket.	Wipe the inside of the bowl with a clean cloth. Discard and replace the gasket if it is cracked or torn. Unscrew and remove the filter element and clean by washing in solvent (fed. spec. P-D-680). If element discs are dented or bent, or cannot be cleaned by washing with solvent, replace element. Reinstall element, bowl, and gasket, and secure by installing bail. Tighten knurled nut.
	Step 3. Check for fuel input at FUEL RECEPTACLE. Disconnect fuel supply line at heater case, and insert into can or pail. Connect power plug and turn on heater. If room thermostat is set above ambient temperature fuel should flow from line.	External fuel pump is not supplied with heater. If there is no fuel flow, check pump and lines per applicable instructions.
	Step 4. Check for power to external fuel pump. Disconnect fuel pump plug. Connect power plug and turn on heater. Check for 24 VDC at terminal in EXTERNAL FUEL PUMP RECEPTACLE.	If there is no power, check fuel pump power supply per steps 5 and 6. If there is power, check fuel pump cable and plug per step 7.
	Step 5. Check wiring to fuel receptacle. Check that yellow wire from fuel pump power supply is tight in electrical connector. Check that fuel pump power supply is securely fastened to heater case, since negative side of power supply output is grounded to case. Check wire connections at receptacle,	

Table 4-2. Organizational Maintenance Troubleshooting - Continued

MALFUNCTION	TESTING OR INSPECTION	CORRECTIVE ACTION
4 - Continued		<p>and green ground connection from receptacle to beater case.</p> <p>Tighten loose connections. Replace defective terminals or broken wire.</p>
	<p>Step 6. Check power supply output. Turn on heater and check for 24 VDC from yellow wire to heater case ground.</p>	<p>If output voltage is not present, replace fuel pump power supply. Turn off heater and disconnect power plug. Disconnect wires from fuel pump power supply to terminal strip, overheat thermostat, and electrical connector. Remove screws and washers securing fuel pump power supply to heater case. Remove defective power supply, and install new one by reversing removal process.</p>
	<p>Step 7. If 24 VDC is available at EXTERNAL FUEL PUMP RECEPTACLE per step 3., check wiring to external fuel pump. Disconnect fuel pump cable at heater and fuel pump. Check for continuity using test light or ohmmeter.</p>	<p>If cable is open, disassemble plug and tighten loose connections. Repair or replace broken cable.</p>
	<p>Step 8. Check for defective fuel pump. Fuel pump is not supplied with heater.</p>	<p>Repair or replace per applicable instructions.</p>
	<p>Step 9. If fuel system is good, inspect igniter. Open access doors and disconnect ignition cable from igniter. Remove igniter from burner head and inspect for dirty or damaged electrode.</p>	<p>If igniter is damaged, discard and install a new igniter in the burner head. If fuel deposits are clogging tip between igniter electrode and ground tube, clean with a wire brush, then reinstall.</p>

Table 4-2. Organizational Maintenance Troubleshooting - Continued

MALFUNCTION**TESTING OR INSPECTION****CORRECTIVE ACTION**

4 - Continued



When checking spark, do not allow spark gap to exceed 1/8 inch. Greater gap will cause excessively high potential buildup resulting in insulation breakdown either internally or in the ignition cable.

Step 10. Check for ignition spark. Remove igniter from burner head, but make sure igniter is tightly connected to ignition cable. Clamp igniter body against a heater case ground. Connect power plug, check that room thermostat is set above ambient temperature, and turn on heater.

If no spark is visible at igniter tip, check per step 11. If spark is visible, check per step 12.

Step 11. Check for power to ignition transformer. Under conditions in step 10, 120 VAC should be present to white and brown leads of ignition transformer.

If no power is present, check wiring to terminal strip. Replace broken wires or tighten loose connections. If power is present, ignition transformer is defective. Turn off power and disconnect power plug. Disconnect white and brown leads from transformer to terminal strip, and ignition cable at transformer output. Remove screws and washers securing transformer to heater case, and install new transformer by reversing removal process.

Step 12. Check flame switch. Disconnect power plug and thermostat plug. Open access doors. When heat exchanger is cool, there must be continuity from the brown wire to the green and the white/black wires. When the heat exchanger is hot, there must be continuity from the brown wire to the orange wire and the blue wire. If flame switch is good, check fuel system per steps 13 and following. If flame switch is bad, replace as follows:

Table 4-2. Organizational Maintenance Troubleshooting - Continued

MALFUNCTION	TESTING OR INSPECTION	CORRECTIVE ACTION
-------------	-----------------------	-------------------

4 - Continued

Disconnect power plug. Disconnect wires at flame switch, (8, fig. 4-5). It is normally possible to remove the flame switch without removing the carburetor or burner head. Remove screws (1), washers (2 and 3) and pull out assembled switch and bracket (4 through 8). Remove screws (4) and washers (5 and 6) securing flame switch (8) to mounting base (7). Pull off defective switch. No repair is possible. Install a new switch by reversing the removal procedure. Make sure tip of switch probe engages bracket on heat exchanger.

Step 13. Check for power to solenoid valve. Open access doors. With power plug connected to heater and room thermostat set above ambient temperature, turn on heater. Check for 24 VDC at electrical connector which supplies power to solenoid valve.

Fuel pump power supply was check per step 6. Turn off power and disconnect power plug. Check continuity at electrical connector between power supply and fuel pump power supply and solenoid valve. Tighten loose connections.

Step 14. Check solenoid coil. Remove hex nut at terminal on solenoid valve. Pull off wire and remove solenoid coil. Check for continuity between solenoid wires.

If coil is open, replace solenoid valve. Using open end wrench, unscrew and remove solenoid stem. Discard old solenoid coil, stem, and related parts. Install stem and preformed packing from new solenoid valve into carburetor body. Install washer and solenoid coil, and connect leads at solenoid terminal. Secure with hex nut.

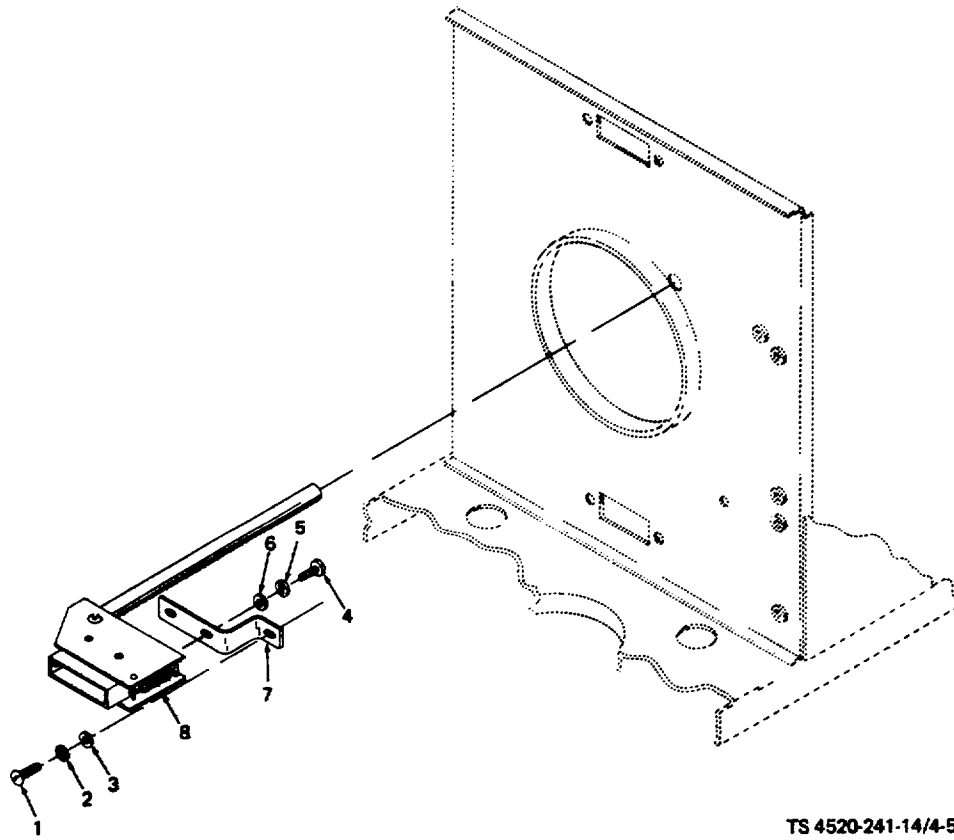

- | | |
|----------------|------------------|
| 1. Screw | 5. Lock washer |
| 2. Lock washer | 6. Flat washer |
| 3. Flat washer | 7. Mounting base |
| 4. Screw | 8. Flame switch |

Figure 4-5. Flame switch mounting.

Table 4-2. Organizational Maintenance Troubleshooting - Continued

MALFUNCTION**TESTING OR INSPECTION****CORRECTIVE ACTION**

4 - Continued

- Step 15. Check for fuel in float bowl. Remove pipe plug (1, fig. 4-6) from side of float bowl. Using small wire or pencil tip, gently tap float. It must bounce up and down to show that fuel is present in bowl. If float bounces, proceed to step 16. If float does not bounce, inspect screen and needle.

Disconnect fuel line from elbow (2, fig. 4-6). Unscrew elbow and pull out screen (3). Clean or replace screen. If it is clean, inspect needle and seat. Remove screws (5) and washers (6). Pull off cover (7) and gasket (8). Remove pin (9) and pull off float (10) and needle (11). If needle or seat (12) is damaged, replace needle, seat, and washer (13) as an assembly. Reassemble in reverse order of removal.

- Step 16. Check for fuel suction. Disconnect solenoid power lead at electrical connector. Use a pencil to mark the position of the fuel needle in the carburetor body. Carefully unscrew and remove fuel needle (1, fig. 4-7), counting the number of turns until needle is free. Connect power plug. Turn on heater and feel for vacuum at the fuel needle hole in the carburetor body. You should feel a vacuum if you place your finger over the hole. If there is a vacuum, check per step 17. If there is no vacuum, clean fuel jet and mixer.

Do not reinstall fuel needle.

Disconnect fuel lines and wires from carburetor. Remove screws (3, fig. 4-7) and washers (4) securing assembled carburetor to burner head. Pull off carburetor.

Pull off preformed packing (6) and clean fuel mixer (5) with a wire brush. Unscrew mixer and remove to expose fuel jet (7). Using a piece of bare 20-gage or 22-gage wire, clean out bore in fuel jet. Do not remove jet from carburetor. Insert wire into end of jet. It should pass through to hole for fuel needle. Reinstall fuel mixer and preformed packing. Reinstall carburetor on burner

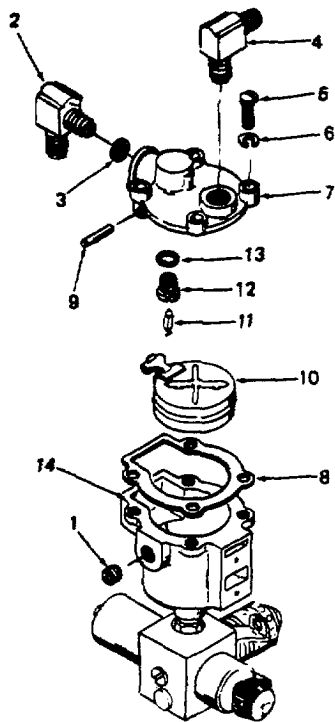

TS 4520-241-14/4-6

KEY to fig. 4-6:

- 1. Plug
- 2. Elbow
- 3. Screen
- 4. Elbow
- 5. Screw
- 6. Washer
- 7. Float bowl cover
- 8. Gasket
- 9. Float pin
- 10. Float
- 11. Needle
- 12. Seat
- 13. Washer
- 14. Float bowl

Figure 4-6. Carburetor inlet screen, needle, and seat.

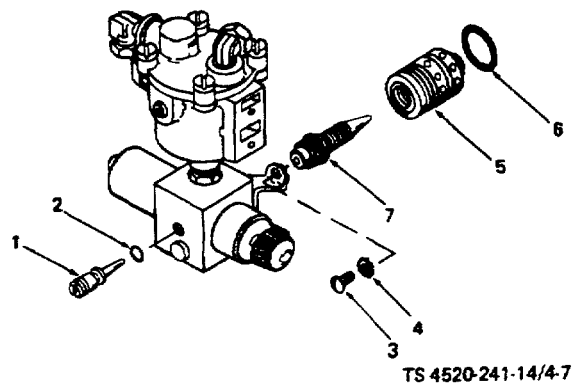

TS 4520-241-14/4-7

- 1. Fuel needle
- 2. Preformed packing
- 3. Screw
- 4. Washer
- 5. Fuel mixer
- 6. Preformed packing
- 7. Fuel jet

Figure 4-7. Fuel mixer and jet.

Table 4-2. Organizational Maintenance Troubleshooting - Continued

MALFUNCTION	TESTING OR INSPECTION	CORRECTIVE ACTION
4 - Continued	head. Connect fuel lines and wires and recheck fuel suction. When suction is good, go to step 17.	Step 17. Turn off heater power. Reconnect solenoid power lead removed in step 16. Do not reinstall fuel needle. Turn on heater for a few seconds. Fuel should flow from hole for fuel needle. If it does flow, carburetor is working properly. Reinstall fuel needle, counting the number of turns to return it to the position it was when removed in step 16.
		If fuel does not flow, proceed to Step 18.
	Step 18. Tighten hex nut (1, fig. 4-8) on end of solenoid (where ground-wire is attached). Repeat fuel flow check in step 17. Nut must be tight to properly compress preformed packing inside. If fuel does not flow after tightening nut, clean and inspect solenoid.	Remove hex nut (1, fig. 4-8) at end of solenoid valve. Pull off solenoid coil (2) and washer (3). Unscrew nut (4) from carburetor body. Pull out stem (5) and nut, and pull out preformed packing (6) from carburetor body. Pull out plunger (7). Do not lose spring (8).
		If preformed packing at end of plunger is swollen or deformed, replace solenoid as an assembly. Only packing (6) is replaceable separately. Inspect passages in solenoid side of carburetor body and remove any foreign material. Probe passages with a thin, bare wire. If solenoid packing is good and passages are clean, reinstall solenoid. Be sure to tighten nut (1) securely to compress preformed packing inside. Repeat fuel flow check in step 17.

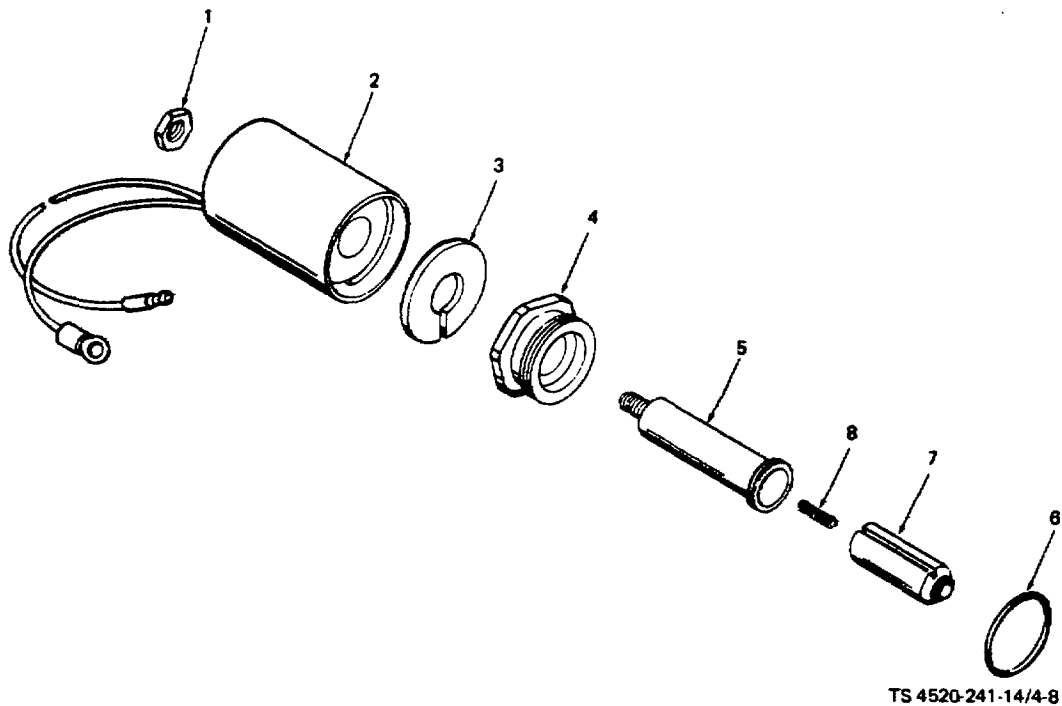

- | | |
|-----------|----------------------|
| 1. Nut | 5. Stem |
| 2. Coil | 6. Preformed packing |
| 3. Washer | 7. Plunger |
| 4. Nut | 8. Spring |

Figure 4-8. Solenoid assembly.

Table 4-2. Organizational Maintenance Troubleshooting - Continued

MALFUNCTION

TESTING OR INSPECTION

CORRECTIVE ACTION

5. HEATER IGNITES, THEN STOPS, AND RED LIGHT COMES ON.

Step 1. Check flame switch. Disconnect power plug and thermostat plug. Open access doors. When heat exchanger is cool, there must be continuity from the brown wire to the green and the white/black wires. When the heat exchanger is hot, there must be continuity from the brown wire to the orange wire and the blue wire.

Disconnect power plug. Disconnect wires at flame switch, (8, fig. 4-9). It is normally possible to remove the flame switch without removing the carburetor or burner head. Remove screws (1),

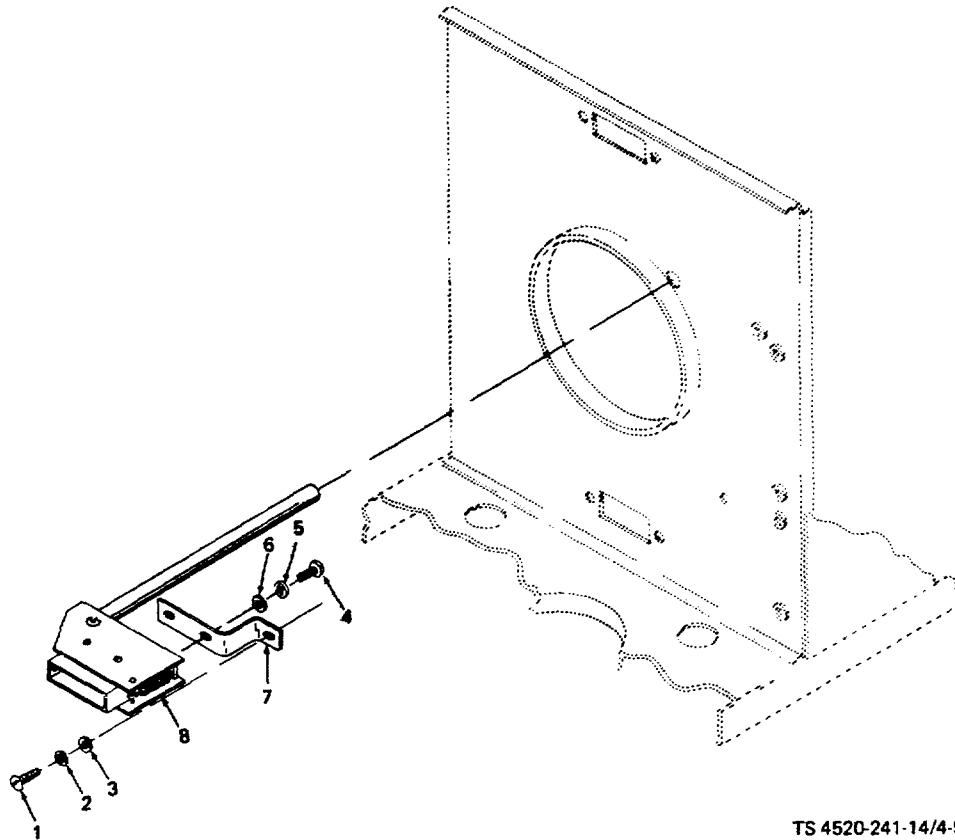

TS 4520-241-14/4-9

- | | |
|----------------|------------------|
| 1. Screw | 5. Lock washer |
| 2. Lock washer | 6. Flat washer |
| 3. Flat washer | 7. Mounting base |
| 4. Screw | 8. Flame switch |

Figure 4-9. Flame switch mounting.

Table 4-2. Organizational Maintenance Troubleshooting - Continued

MALFUNCTION	TESTING OR INSPECTION	CORRECTIVE ACTION
-------------	-----------------------	-------------------

5 - Continued

washers (2 and 3) and pull out assembled switch and bracket (4 through 8). Remove screws (4) and washers (5 and 6) securing flame switch (8) to mounting base (7). Pull off defective switch. No repair is possible. Install a new switch by reversing the removal procedure. Make sure tip of switch probe engages bracket on heat exchanger.

6. HEATER IGNITES, BUT VENTILATING MOTOR FAILS TO RUN.

Step 1. Check power to ventilating motor. Connect power plug. Move HEATER-OFF-FAN switch to FAN.

If fan runs, proceed to step 2. If fan fails to run, proceed to step 3.

Step 2. Check wiring from flame switch to motor. Orange wire from flame switch and orange wire from motor connect at same terminal on terminal strip.

Tighten loose connections or replace broken wires.

Step 3. With conditions in step 1, check for 120 volts at motor terminals.

If there is no power, tighten loose connections or replace broken wires.

7. HEATER BACKFIRES.

Step 1. Check for correct fuel adjustment.

Adjust fuel needle as follows:

Start the heater and allow it to warm up for a few minutes.

Open the front access door and turn the fuel needle (fig. 4-10) clockwise gently until it is seated in the carburetor body.

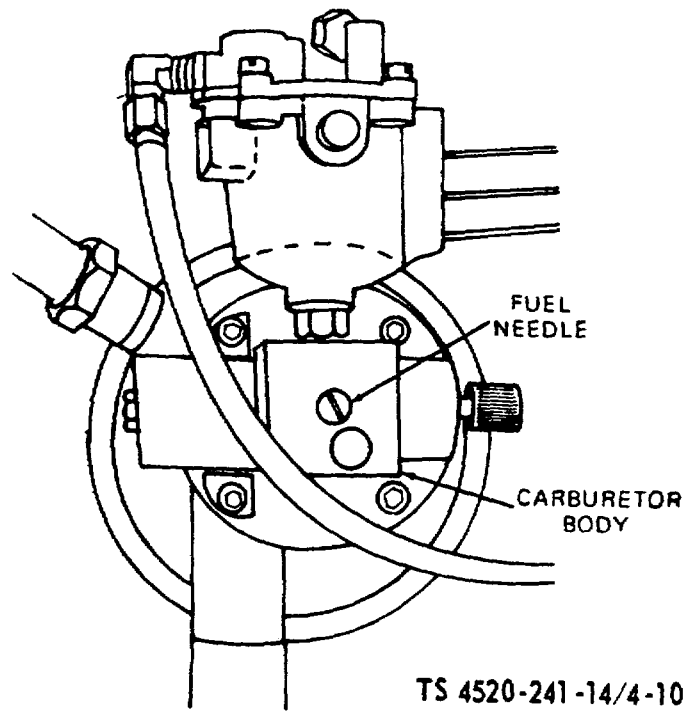

Figure 4-10. Fuel needle adjustment.

Table 4-2. Organizational Maintenance Troubleshooting - Continued

MALFUNCTION

TESTING OR INSPECTION

CORRECTIVE ACTION

7 - Continued



Do not force the fuel needle. This may damage the fuel orifice and make correct adjustment difficult or impossible.

Turn the needle counterclockwise one full turn, then continue only in 1/8 turn increments. After each increment, inspect the exhaust. The fuel flow should be increased until there is no odor of unburned fuel or any smoke.

Table 4-2. Organizational Maintenance Troubleshooting - Continued

MALFUNCTION	TESTING OR INSPECTION	CORRECTIVE ACTION
-------------	-----------------------	-------------------

7 - Continued

Step 2. Inspect igniter. Open access doors and disconnect ignition cable from igniter. Remove igniter from burner head and inspect for dirty or damaged electrode.

If igniter is damaged, discard it and install a new igniter in the burner head. If fuel deposits are clogging tip between igniter electrode and ground tube, clean with a wire brush, then reinstall.



When checking spark, do not allow spark gap to exceed 1/8 inch. Greater gap will cause excessively high potential buildup resulting in insulation breakdown either internally or in the ignition cable. Always ground igniter body during inspection.

Step 3. Check for ignition spark. Remove igniter from burner head, but make sure igniter is tightly connected to ignition cable. Clamp igniter body against a heater case ground. Connect power plug, check that room thermostat is set above ambient temperature, and turn on heater.

If spark is weak or intermittent, ignition transformer is defective. Turn off power and disconnect power plug. Disconnect white and brown leads from transformer to terminal strip, and ignition cable at transformer output. Remove screws and washers securing transformer to heater case, and install new transformer by reversing removal process.

Step 4. Check combustion air duct. Inspect for loose or damaged air duct.

Tighten clamps at burner head and combustion air motor outlet. If duct is punctured or torn, loosen clamps and remove damaged air duct. Install new duct and secure with clamps.

Table 4-2. Organizational Maintenance Troubleshooting - Continued

MALFUNCTION**TESTING OR INSPECTION****CORRECTIVE ACTION**

7 - Continued

Step 5. Check wiring to combustion motor. Inspect wiring from terminal strip to motor.

Tighten loose connections, or replace broken wires.

Step 6. Check for exhaust system obstructions. Inspect exhaust line for blockage, kinks, or bends which could restrict the flow of exhaust gases from the heat exchanger.

Exhaust lines are not supplied with the heater. Clean out, repair, or replace defective pipe or tube as applicable.

8. HEATER SMOKES.

Step 1. Check for correct fuel adjustment.

Adjust fuel needle as follows:

Start the heater and allow it to warm up for a few minutes.

Open the front access door and turn the fuel needle clockwise gently until it is seated in the carburetor body.



Do not force the fuel needle. This may damage the fuel orifice and make correct adjustment difficult or impossible.

Turn the needle counterclockwise in 1/8 turn increments. After each increment, inspect the exhaust. The fuel flow should be increased until there is no odor of unburned fuel or any smoke.

Step 2. Check combustion air duct. Inspect for loose or damaged air duct.

Table 4-2. Organizational Maintenance Troubleshooting - Continued

MALFUNCTION	TESTING OR INSPECTION	CORRECTIVE ACTION
8 - Continued	Tighten clamps at burner head and combustion air motor outlet. If duct is punctured or torn, loosen clamps and remove damaged air duct. Install new duct and secure with clamps.	
	Step 3. Check wiring to combustion motor. Inspect wiring from terminal strip to motor.	Tighten loose connections, or replace broken wires.
	Step 4. Check for fuel in float bowl. Remove pipe plug (1, fig. 4-11) from side of float bowl. Using small wire or pencil tip, gently tap float. It must bounce up and down to show that fuel is present in bowl. If float bounces, proceed to step 5. If float does not bounce, inspect screen and needle.	Disconnect fuel line from elbow (2, fig. 4-11). Unscrew elbow and pull out screen (3). Clean or replace screen. If it is clean, inspect needle and seat. Remove screws (5) and washers (6). Pull off cover (7) and gasket (8). Remove pin (9) and pull off float (10) and needle (11). If needle or seat (12) is damaged, replace needle, seat, and washer (13) as an assembly. Reassemble in reverse order of removal.
	Step 5. Check for fuel suction. Disconnect solenoid power lead at electrical connector. Use a pencil to mark the position of the fuel needle in the carburetor body. Carefully unscrew and remove fuel needle (1, fig. 4-12) counting the number of turns until needle is free. Connect power plug. Turn on heater and feel for vacuum at the fuel needle hole in the carburetor body. You should feel a vacuum if you place your finger over the hole. If there is a vacuum, check per step 6. If there is no vacuum, clean fuel jet and mixer.	Do not reinstall fuel needle.
		Disconnect fuel lines and wires from carburetor. Remove screws (3, fig. 4-12) and washers (4)

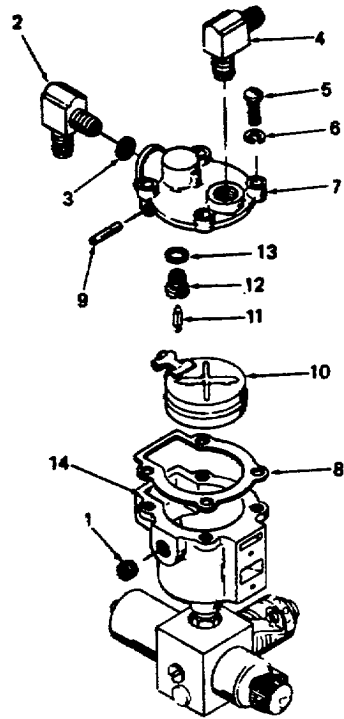

TS 4520-241-14/4-11

- | | |
|---------------------|----------------|
| 1. Plug | 8. Gasket |
| 2. Elbow | 9. Float pin |
| 3. Screen | 10. Float |
| 4. Elbow | 11. Needle |
| 5. Screw | 12. Seat |
| 6. Washer | 13. Washer |
| 7. Float bowl cover | 14. Float bowl |

Figure 4-11. Carburetor inlet screen, needle, and seat.

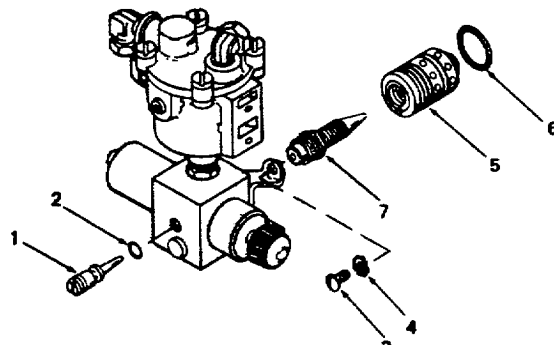

TS 4520-241-14/4-12

- | | |
|----------------------|----------------------|
| 1. Fuel needle | 5. Fuel mixer |
| 2. Preformed packing | 6. Preformed packing |
| 3. Screw | 7. Fuel jet |
| 4. Washer | |

Figure 4-12. Fuel mixer and jet.

Table 4-2. Organizational Maintenance Troubleshooting - Continued

MALFUNCTION	TESTING OR INSPECTION	CORRECTIVE ACTION
8 - Continued		<p>securing assembled carburetor to burner head. Pull off carburetor. Pull off preformed packing (6) and clean fuel mixer (5) with a wire brush. Unscrew mixer and remove to expose fuel jet (7). Using a piece of bare 20-gage or 22-gage wire, clean out hole in fuel jet. Do not remove jet from carburetor.</p> <p>Insert wire into end of jet. It should pass through to hole for fuel needle. Reinstall fuel mixer and preformed packing. Reinstall carburetor on burner head. Connect fuel lines and wires and recheck fuel suction. When suction is felt, go to step 6.</p> <p>Step 6. Turn off heater power. Reconnect solenoid power lead removed in step 5. Do not reinstall fuel needle. Turn on heater for a few seconds. Fuel should flow from hole for fuel needle. If it does flow, carburetor is working properly. Reinstall fuel needle, counting the number of turns to return it to the position it was when removed in step 5. If fuel does not flow, proceed to step 7.</p> <p>Step 7. Tighten hex nut (1, fig. 4-13) on end of solenoid (where ground wire is attached). Repeat fuel flow check in step 6. Nut must be tight to properly compress preformed packing inside. If fuel does not flow after tightening nut, clean and inspect solenoid.</p> <p>Remove hex nut (1, fig. 4-13) at end of solenoid valve. Pull off solenoid coil (2) and washer (3). Unscrew nut (4) from carburetor body. Pull out stem (5) and nut, and pull out preformed packing (6) from carburetor body. Pull out plunger (7). Do not lose spring (8). If preformed packing at end of plunger is swollen or deformed, replace solenoid as an assembly. Only packing (6) is replaceable separately. Inspect passages in solenoid side of carburetor body and remove any foreign material. Probe passages with a thin, bare wire. If solenoid packing is good and</p>

Table 4-2. Organizational Maintenance Troubleshooting - Continued

MALFUNCTION

TESTING OR INSPECTION

CORRECTIVE ACTION

8 - Continued

passages are clean, reinstall solenoid. Be sure to tighten nut (1) securely to compress preformed packing inside. Repeat fuel flow check in step 6.

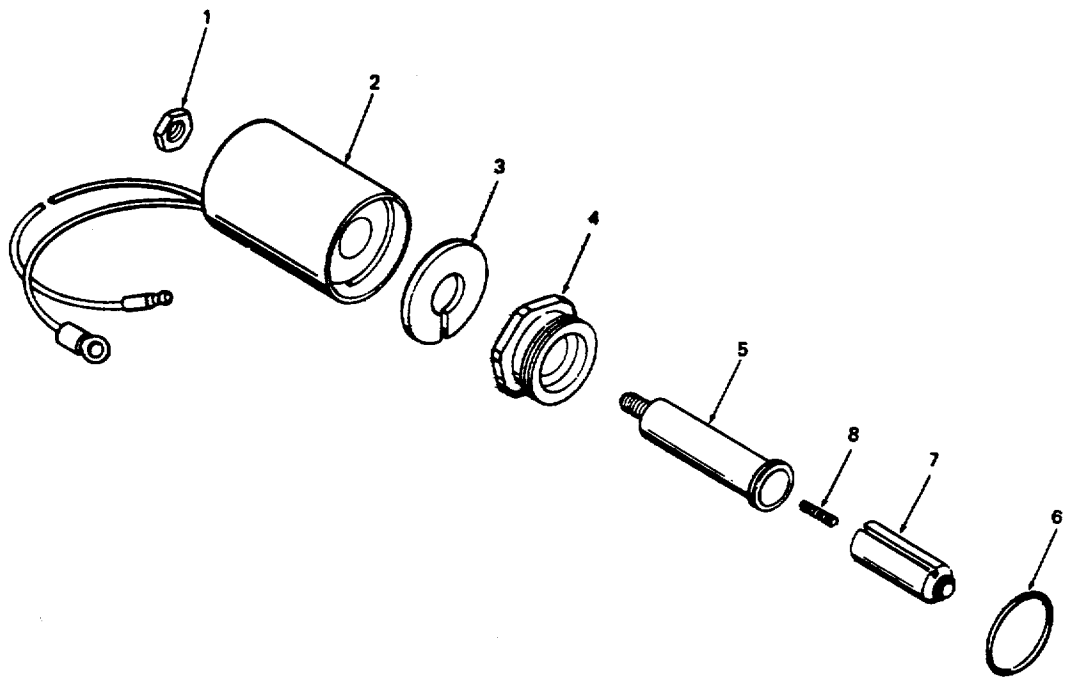

TS 4520-241-14/4-13

- | | |
|-----------|----------------------|
| 1. Nut | 5. Stem |
| 2. Coil | 6. Preformed packing |
| 3. Washer | 7. Plunger |
| 4. Nut | 8. Spring |

Figure 4-13. Solenoid assembly.

SECTION VI. RADIO INTERFERENCE SUPPRESSION**4-14. GENERAL METHODS USED TO ATTAIN PROPER SUPPRESSION.**

Essentially, suppression is attained by providing a low resistance path to ground for stray currents. The primary methods used include: installation of capacitors on the combustion motor, and the incorporation of an interference suppression filter in the filter and receptacle assembly (POWER RECEPTACLE). The secondary methods consist of shielding on the ignition cable and the igniter.

4-15. PRIMARY INTERFERENCE SUPPRESSION COMPONENTS.

a. Two 0.47 microfarad, 10 ampere, 200 VDC capacitors (1, fig. 4-14) are installed in series in the combustion motor. Their function is to suppress radio frequency (RF) interference generated by the arcing of the brushes at the motor commutator.

b. The filter and receptacle assembly (2) has an integral interference filter composed of resistors and capacitors. The receptacle portion of this assembly is the POWER RECEPTACLE.

4-16. REPLACEMENT OF SUPPRESSION COMPONENTS.**WARNING**

This space heater contains dangerous voltages which can cause severe electrical shock. Be sure to disconnect the power plug before repairing the heater.

a. Suppression capacitors are in the combustion motor assembly, and should be replaced only by direct support maintenance personnel.

b. To replace the filter and receptacle assembly, remove the side panel adjacent to the POWER RECEPTACLE. Tag and unsolder the wires to the back of the filter, and remove the screws, nuts, and washers which secure the filter and receptacle assembly to the heater case. This assembly is not repairable. Discard a defective receptacle and install a new one in the reverse order of removal. Be sure to use rosin core electrical solder when soldering the wires to the back of the filter.

4-17. SECONDARY SUPPRESSION COMPONENTS.

These are components which have radio interference suppression incidental or secondary to their primary function.

a. The ignition cable shielding acts as an interference suppressor. It is not repairable, and the entire ignition cable must be replaced if the shielding is damaged.

b. The igniter has some shielding characteristics. It is not repairable. If it becomes a source of radio interference, replace it.

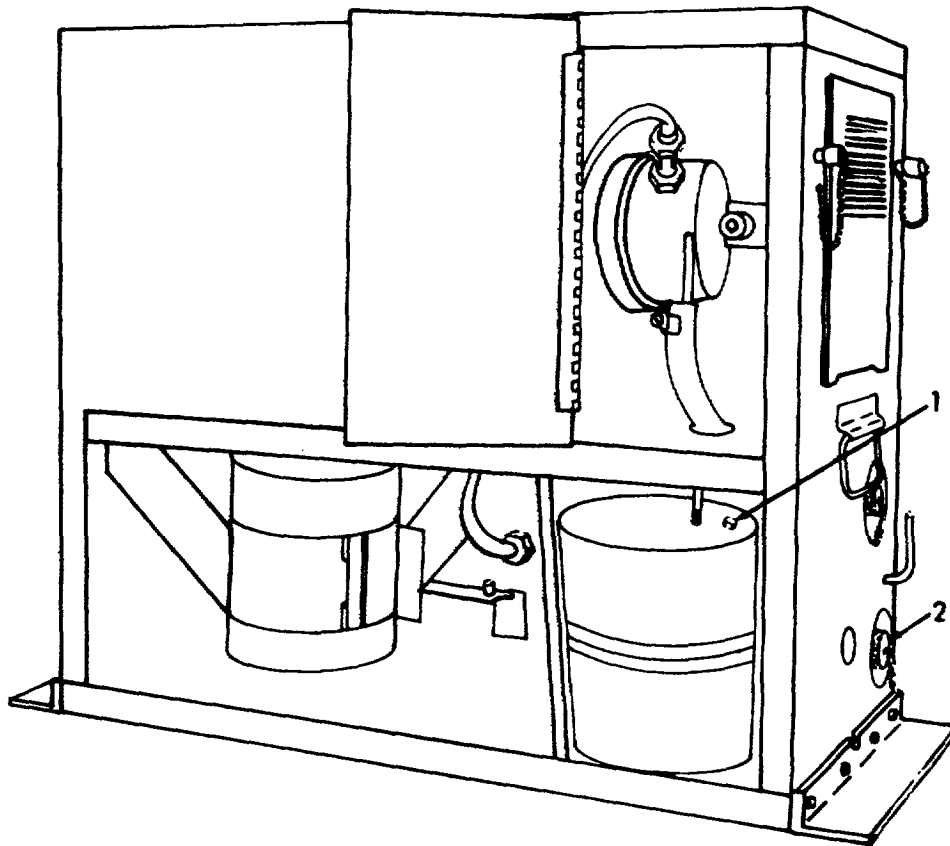

TS 4520-241-14/4-14

1. Suppression capacitors
2. Filter and receptacle assembly

Figure 4-14. Primary radio interference suppression components.

4-18. TESTING OF RADIO INTERFERENCE SUPPRESSION COMPONENTS.

Refer testing of the suppression capacitors to direct support maintenance.

SECTION VII. MAINTENANCE OF CONTROL BOX ASSEMBLY**4-19. DESCRIPTION.**

a. Control Box, Electrical Receptacles, and Circuit Breaker. The control box fastens directly on the front of the heater, and may be rotated in 90 degree increments to correspond to the mounting position of the heater. The control box houses the room thermostat receptacle and the circuit breaker. It also provides a cavity for the electrical components in the control box cover.

b. Control Box Wiring Harness. This harness connects the electrical circuitry in the control box cover to a male plug. This plug is inserted into a mating receptacle in the front of the heater case.

c. Control Box Cover. The cover contains a printed circuit board assembly and a transistor to simplify the circuitry of the time delay mechanism. It also contains the indicator lights, the time delay assembly, and the HEATER-OFF-FAN switch that controls the heater operation.

d. Time Delay Transformer. This unit is functionally part of the item delay assembly, but it is not located in the control box. The transformer is just below the terminal board inside the right side access door.

4-20. CONTROL BOX, ELECTRICAL RECEPTACLES, AND CIRCUIT BREAKER.**WARNING**

This space heater contains dangerous voltages which can cause severe electrical shock. Be sure to disconnect the power plug before repairing the heater.

a. Removal and Disassembly.

(1) Disconnect the power plug from the power plug receptacle.

(2) Open the control box cover and unplug the control box harness (2, fig. 4-15). Save gasket (1).

(3) Remove the control box from the heater by releasing the two stud assemblies (19).

(4) Remove nuts (3), lock washer (4 and 5), and screw (6) to remove the grounding leads.

(5) Remove nuts (7), lock washers (8), and screws (9) to separate the control box cover (10) from control box weldment (23).

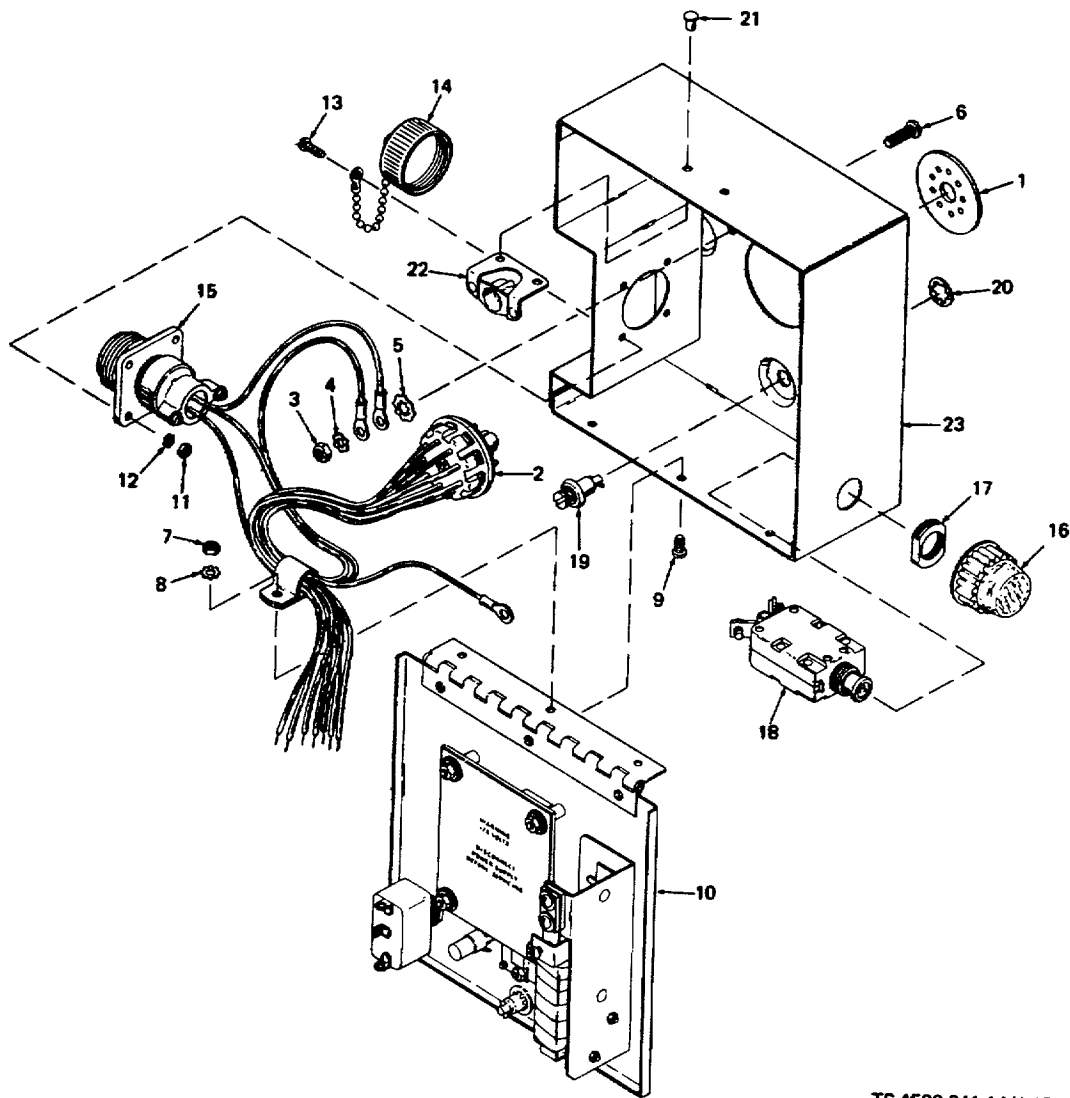

TS 4520-241-14/4-15

- | | |
|--------------------------------|--------------------------------|
| 1. Gasket | 13. Screw |
| 2. Control box harness | 14. Dust cap |
| 3. Nut | 15. Room thermostat receptacle |
| 4. Lock washer | 16. Flexible seal |
| 5. Lock washer | 17. Adapter |
| 6. Screw | 18. Circuit breaker |
| 7. Nut | 19. Stud assembly |
| 8. Lock washer | 20. Washer |
| 9. Screw | 21. Rivet |
| 10. Control box cover assembly | 22. Fastening receptacle |
| 11. Nut | 23. Control box weldment |
| 12. Lock washer | |

Figure 4-15. Control box, electrical receptacles, and circuit breaker.

(6) Remove room thermostat receptacle (15) by removing nuts (11), lock washers (12), screws (13), and dust cap (14). If the receptacle must be replaced, disassemble the receptacle and unsolder the wires.

(7) Remove flexible seal (16). Unscrew adapter (17) and remove the circuit breaker (18). Disconnect the wires.

b. Cleaning and Inspection.

(1) Clean all parts by wiping with a clean, dry cloth.

(2) Inspect the receptacle for damaged insulation and for bent or damaged pins. No repair of the receptacle is possible, and it must be replaced if defective.

(3) Check the circuit breaker for continuity. If it is open, and continuity cannot be restored by pressing the button, replace the circuit breaker.

(4) Check that the stud assemblies (19) operate properly. If they are loose or damaged, drive them out of the control box weldment. Install a new stud assembly and retain by pressing on a new washer (20).

(5) Inspect fastening receptacle (22) for looseness and excessive wear. If it is loose, tighten by peening the heads of rivets (21). If the receptacle is worn so that the control box cover cannot be fastened securely, drill out the rivets and install a new receptacle.

(6) Inspect all hardware parts for stripped threads and other damage. Replace defective parts.

(7) Inspect the control box weldment for dents and bent walls. Straighten dents if possible, or replace the control box assembly. Touch up scratched and chipped paint before reassembly.

c. Reassembly and Installation. Reassembly and installation of the control box are essentially the reverse of removal and disassembly. Note the following:

(1) When connecting wires to the circuit breaker, either black wire can be connected to either terminal.

(2) When connecting wires to the receptacle, connect the violet wire to pin A, the green wire to pin B, and the white/black wire to pin C. Solder the wires to the receptacle pins using rosin core electrical solder.

4-21. CONTROL BOX WIRING HARNESS.

WARNING

This space heater contains dangerous voltages which can cause severe electrical shock. Be sure to disconnect the power plug before repairing the heater.

- a. Check all connections on the wiring harness to see that they are securely fastened to their respective terminals. There are nine wires soldered to the male plug and three soldered to the room thermostat receptacle.
- b. Check to see that the nine wires from the male plug and the violet wire from the room thermostat receptacle are held by a clamp. The clamp should be fastened to the middle screw which fastens the control box cover to the control box weldment.
- c. The two green leads with ring terminals should be fastened to the grounding screw in the control box.
- d. If there is any evidence of poor connections, overheated wires, damaged receptacles, or faulty insulation, report the condition to direct support maintenance.

4-22. HEATER-OFF-FAN SWITCH.



This space heater contains dangerous voltages which can cause severe electrical shock. Be sure to disconnect the power plug before repairing the heater.

- a. Inspection.
 - (1) Check the switch for continuity from the OFF terminal to the respective ON terminal when the switch toggle is moved toward that terminal. There must be no continuity between the OFF terminal and either ON terminal when the toggle is in the center position.
 - (2) Make sure the switch toggle snaps firmly into all three operating positions.
- b. Removal.
 - (1) Remove the HEATER-OFF-FAN switch from the control panel cover by loosening the hex nut on the front of the panel.
 - (2) Unsolder the five leads from the switch connection lugs. Tag them, or make a notation of the connections.
- c. Installation.
 - (1) Solder the leads to the new switch as shown in figure 4-16, using rosin core electrical solder.
 - (2) When the joints have cooled, spray the terminals with a moisture seal conforming to MIL-V-173 (Columbia Technical Corp., HumiSeal No. 1A27, Class A, 105°C, or equivalent).

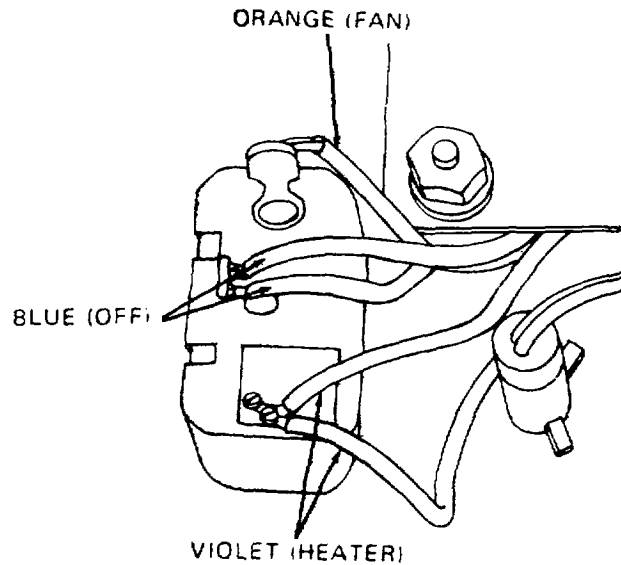

TS 4520-241-14/4-16

Figure 4-16. HEATER-OFF-FAN switch wiring.

4-23. TIME DELAY TRANSFORMER.

- a. Testing. Test the time delay transformer as follows before removing it from the heater case.

WARNING

The space heater contains dangerous voltages which can cause severe electrical shock. When making tests with power applied, take care to prevent contact with live circuits.

- (1) Open the front and side access doors. Locate the time delay transformer under the terminal strip next to the carburetor. Connect a DC voltmeter to the terminals with the red and yellow wires.
- (2) Momentarily move the HEATER-OFF-FAN switch to HEATER. The voltmeter must indicate 23 to 30 volts DC. If there is no voltage, or if the voltage is out of range, replace the transformer as described below.

- b. Replacement.

WARNING

This space heater contains dangerous voltages which can cause severe electrical shock. Be sure to disconnect the power plug before repairing the heater.

(1) Disconnect the power plug and open the access doors. Disconnect the red, yellow, grey, and white wires from the transformer.

(2) Remove the screws and washers which secure the transformer to the heater case and remove the transformer.

(3) Install a new transformer and secure it to the heater case. Connect the wires as shown in the wiring diagram. Close the access doors, connect the power plug, and check for proper operation of the heater.

SECTION VIII. MAINTENANCE OF HEATER CASE ASSEMBLIES

4-24. DESCRIPTION.

a. Heater Case. The heater case consists of a steel framework with a shelf and bulkhead which together form four compartments.

b. Side Panels and Louver Linkage. Right and left side panels cover the entire area below the shelf. Both panels are fastened with stud turnlock fasteners, and have louvers for air intake near the rear of the heater. A louver linkage operated from the front panel of the heater controls the louver positions. When the handle is moved back and forth, one set of louvers opens while the other closes.

c. Doors and Bottom Cover. An access door in the front panel and one on each side of the heater above the side panels provide access to the most frequently adjusted and serviced components. The bottom cover, located on the side opposite the discharge outlet, can be removed for additional air intake if the louvers do not provide enough air.

d. Data Plates. Data plates affixed to the heater case contain a wiring diagram and a circuit schematic diagram. A U.S. government data plate is also provided. The manufacturer's operating data is imprinted on the cover of the control box assembly.

4-25. HEATER CASE ASSEMBLY.

a. Disassembly.



This space heater contains dangerous voltages which can cause severe electrical shock. Be sure to disconnect the power plug before repairing the heater.

(1) A grommet (1, fig. 4-17) protects the ignition cable. If the grommet is cracked, worn, or damaged, work it out of the hole in the heater case. Normally, the ignition cable need not be removed to replace the grommet.

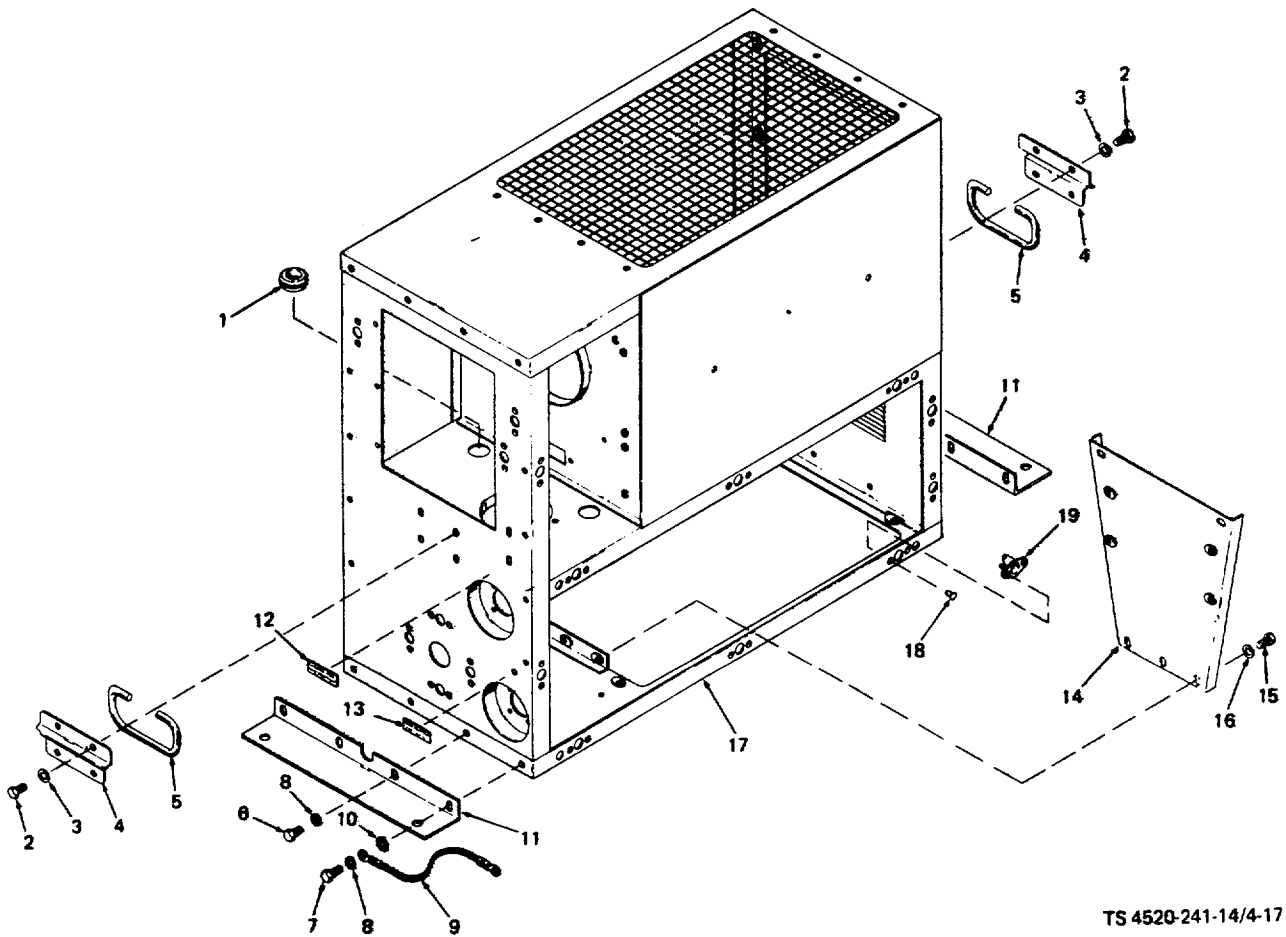

TS 4520-241-14/4-17

- | | |
|--------------------|----------------------------------|
| 1. Grommet | 10. Lock washer |
| 2. Screw | 11. Mounting bracket |
| 3. Lock washer | 12. Label, fuel receptacle |
| 4. Handle plate | 13. Label, power receptacle |
| 5. Handle | 14. Bulkhead |
| 6. Screw | 15. Screw |
| 7. Screw | 16. Lock washer |
| 8. Lock washer | 17. Heater case |
| 9. Grounding strap | 18. Rivet |
| | 19. Turnlock fastener receptacle |

Figure 4-17. Heater case assembly.

(2) Remove screws (2), lock washers (3), handle plates (4), and handles (5) from both the front and the rear of the heater case.

(3) Remove screws (6 and 7), lock washers (8 and 10), and grounding strap (9). Remove mounting brackets (11) from the heater case.

(4) Remove labels (12 and 13) only if they are illegible.

(5) If bulkhead (14) is damaged, disconnect the ignition cable, remove the screws which secure the ignition transformer to the bulkhead, and pull off the ignition transformer. Remove the screw and nut which secure the louver linkage pivot control bar to the bulkhead. Remove the screws (15) and lock washers (16) which secure the bulkhead to the heater case, and pull off the bulkhead.

(6) If turnlock fastener receptacles (19) are worn or damaged, drill out rivets (18) which secure the receptacle to the heater case.

b. Cleaning and Inspection.

WARNING

Clean parts in a well-ventilated area. Avoid inhalation of solvent fumes and prolonged exposure of skin to cleaning solvent. Wash exposed skin thoroughly. Dry cleaning solvent (fed. spec. P-D-680) used to clean parts is potentially dangerous to personnel and property. Do not use near open flame or excessive heat. Flash point of solvent is 100°F (38°C).

(1) Using a dry cloth, wipe dust and lint from the case. Remove greasy or gummy deposits with a cloth dampened with dry cleaning solvent (fed. spec. P-D-680).

(2) Check the inside of the heater case for accumulations of dust and lint. If vacuum cleaning equipment is available, use it to clean the inside of the heater case, taking care not to disturb the wiring or damage components. If vacuum cleaning equipment is not available, use a clean, dry cloth to remove accumulations of dust and lint.

(3) Replace any screws with damaged threads, and touch up any damaged paint to prevent corrosion.

(4) Inspect all surfaces for distortion, cracks, severe dents, or other damage. Refer to direct support maintenance for repair.

c. Reassembly. Reassembly is the reverse of disassembly.

4-26. SIDE PANELS AND LOUVER LINKAGE.

a. Disassembly.

(1) Remove the right and left side louvered panels (1 and 4, fig. 4-18) by turning the stud turnlock fasteners (2) counterclockwise. The push-on nuts (3) and stud turnlock fasteners remain on the panels.

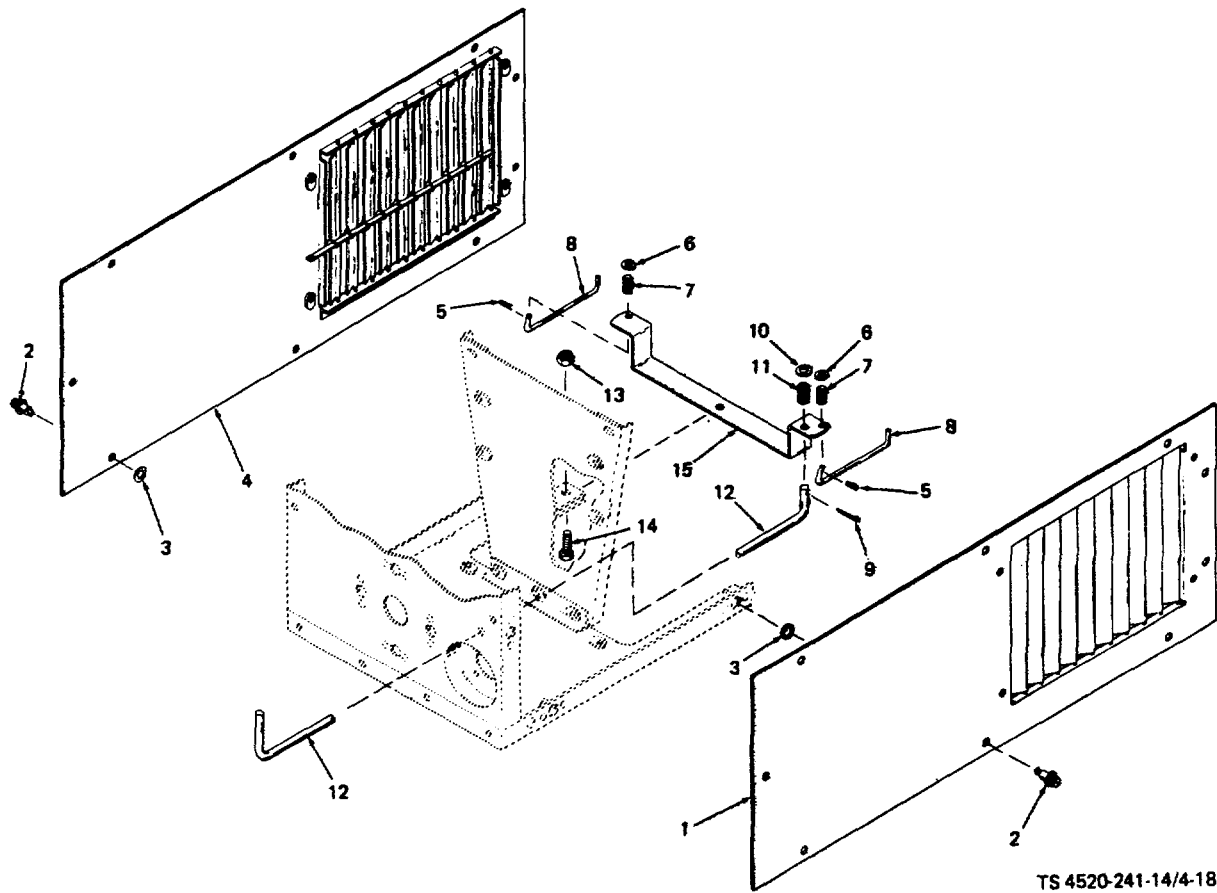

TS 4520-241-14/4-18

- | | |
|------------------------------|-----------------------------|
| 1. Right side louvered panel | 9. Cotter pin |
| 2. Stud turnlock fastener | 10. Washer |
| 3. Push-on nut | 11. Spring |
| 4. Left side louvered panel | 12. Louver operating handle |
| 5. Cotter pin | 13. Nut |
| 6. Washer | 14. Screw |
| 7. Spring | 15. Pivot control bar |
| 8. Louver linkage | |

Figure 4-18. Side panels and louver linkage.

- (2) Remove cotter pins (5), washers (6), and spring (7) to remove louver linkage (8).
- (3) Remove cotter pin (9), washer (10), and spring (11) to remove louver operating handle (12).
- (4) Remove nut (13) from screw (14) to remove the pivot control bar (15) from the bulkhead.

b. Cleaning and Inspection.**WARNING**

Clean parts in a well-ventilated area. Avoid inhalation of solvent fumes and prolonged exposure of skin to cleaning solvent. Wash exposed skin thoroughly. Dry cleaning solvent (fed. spec. P-D-680) used to clean parts is potentially dangerous to personnel and property. Do not use near open flame or excessive heat.

(1) Using a dry cloth, wipe dirt and lint from the side panels and louvers. Remove greasy or gummy deposits with a cloth dampened with solvent (P-D-680).

(2) Inspect louver springs for distortion or cracks. Replace if necessary.

(3) Inspect louver linkage and louver operating handle for bends which might interfere with smooth operation.

(4) Touch up any unpainted areas to prevent corrosion.

c. Reassembly. Reverse the disassembly procedure to reinstall the louver linkage and side panels.

4-27. DOORS AND BOTTOM COVER.a. Disassembly.

(1) With a screwdriver, release the stud turnlock fasteners (6, fig. 4-19) which hold the three access doors closed.

(2) If the doors must be taken off, remove nuts (1), lock washers (2), and screws (3).

(3) You can then remove the front access door (4), left side access door (7) and right side access door (8).

(4) The bottom panel (11) is removed by unscrewing the six screws (9) and removing lock washers (10).

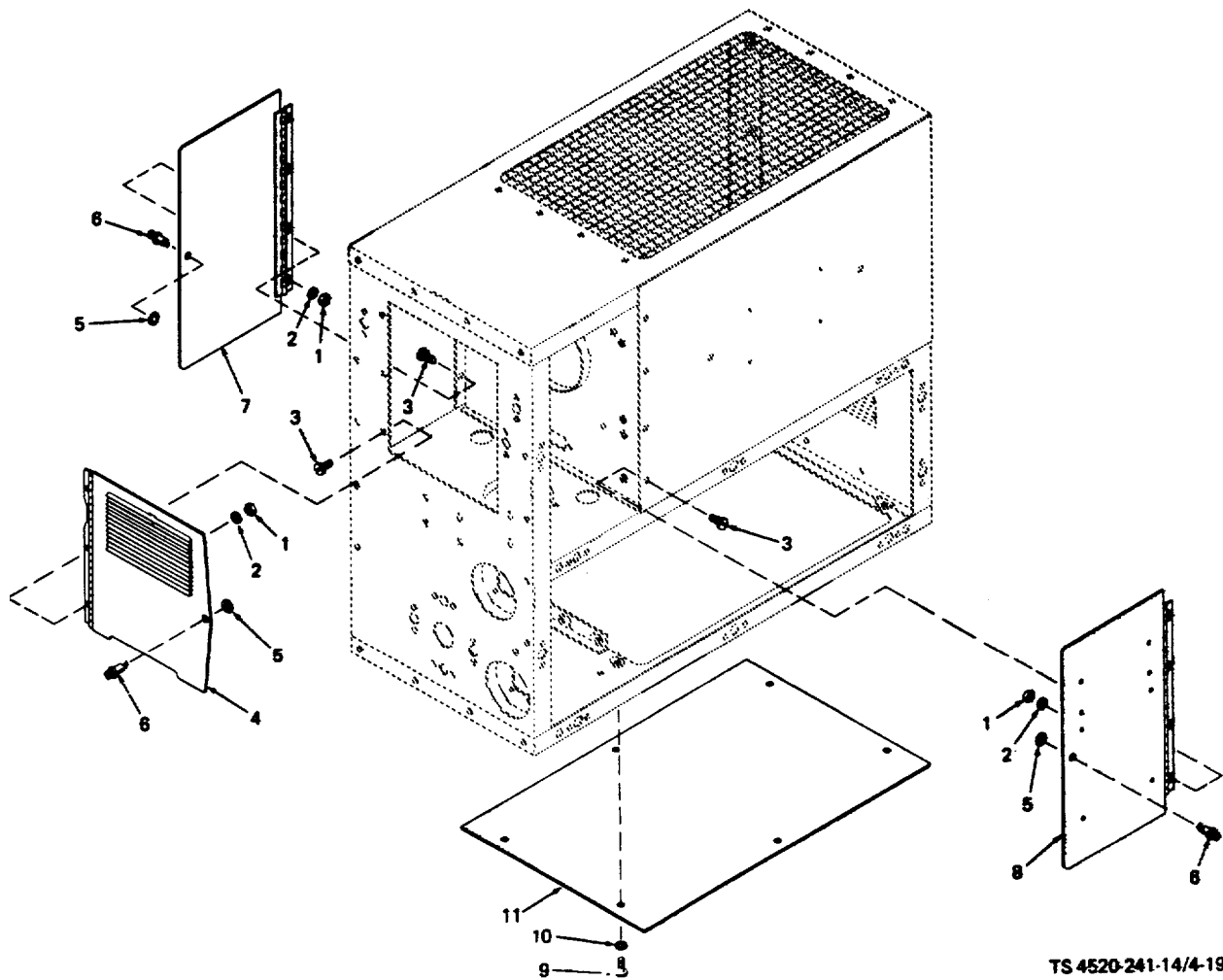

TS 4520-241-14/4-19

- | | |
|---------------------------|---------------------------|
| 1. Nut | 7. Left side access door |
| 2. Lock washer | 8. Right side access door |
| 3. Screw | 9. Screw |
| 4. Front access door | 10. Lock washer |
| 5. Washer | 11. Bottom cover |
| 6. Stud turnlock fastener | |

Figure 4-19. Doors and bottom cover.

b. Cleaning and Inspection.

WARNING

Clean parts in a well-ventilated area. Avoid inhalation of solvent fumes and prolonged exposure of skin to cleaning solvent. Wash exposed skin thoroughly. Dry cleaning solvent (fed. spec. P-D-680) used to clean parts is potentially dangerous to personnel and property. Do not use near open flame or excessive heat. Flash point of solvent is 100°F (38°C).

(1) Using a dry cloth, wipe dirt and lint from the doors and bottom cover. Remove greasy or gummy spots with a cloth dampened with solvent (P-D-680).

(2) Inspect the door hinges for bends or other damage which prevents the doors from closing properly. Replace the entire door if it will not close.

(3) Replace the bottom cover if it is bent so much that the heater cannot be mounted level.

(4) Touch up any unpainted areas to prevent corrosion.

(5) Replace the stud turnlock fasteners if the slotted heads are stripped or if they do not hold the doors securely fastened.

c. Reassembly. Reverse the disassembly procedure.

4-28. DATA PLATES.

All four data plates (fig. 4-20) should be checked for legibility, and replaced if they are not legible. All but the one which is embossed on the control box cover are riveted. If rivets are loose, drill them out and replace. The control box cover contains electrical components, and should be replaced only by direct support maintenance.

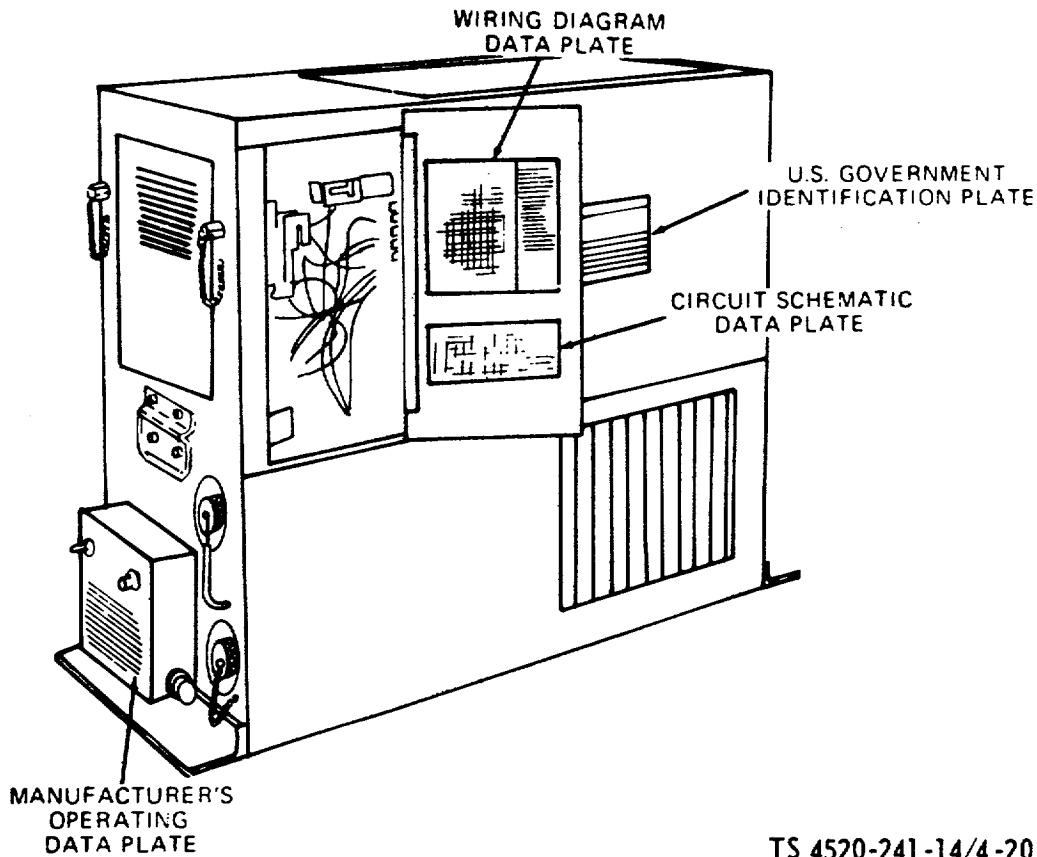

TS 4520-241-14/4-20

Figure 4-20. Data Plates.

SECTION IX. MAINTENANCE OF FUEL SYSTEM

4-29. DESCRIPTION.

a. Fuel Lines and Fittings. There are two nylon fuel lines. One connects the fuel filter to the carburetor inlet port. The other runs from the top of the carburetor float bowl to the overflow receptacle on the front of the heater. Fittings are standard brass male, elbow, nipples, and connectors. The heater is designed for use with an external fuel pump, and a power supply for a fuel pump is provided.

b. Fuel Filter. A bowl-type fuel filter with a replaceable element strains the fuel before it reaches the carburetor.

c. Carburetor. The carburetor controls the fuel flow to the burner. A solenoid valve permits or restricts fuel flow, while the fuel needle's position in the fuel jet determines the rate of flow. A cartridge-type heater is built into the carburetor body to preheat fuel when necessary. The float bowl assembly assures a steady supply of fuel to the burner as well as an overflow relief if the burner cannot accept the fuel. A manual choke is provided for cold weather starting.

d. Solenoid Valve. The solenoid valve is energized to permit fuel flow through the carburetor only when conditions are correct for combustion.

4-30. FUEL LINES AND FITTINGS.

WARNING

This space heater contains dangerous voltages which can cause severe electrical shock. Be sure to disconnect the power plug before repairing the heater.

a. Disassembly.

(1) Disconnect the power plug, and shut off the fuel supply.

(2) Using a wrench, remove the nylon tubing (1, fig. 4-21) from the male elbows (2) by backing off the nuts.

(3) Unthread the three male elbows, two from the carburetor (3) and one from the fuel filter (4).

(4) Remove screws (5), seal caps (6), lock washers (7), and receptacle plates (8). This permits removal of the two bulkhead fittings (9) from the front of the heater.

(5) Unscrew one bulkhead fitting (9) from hex nipple (10), and then unscrew the nipple from the fuel filter.

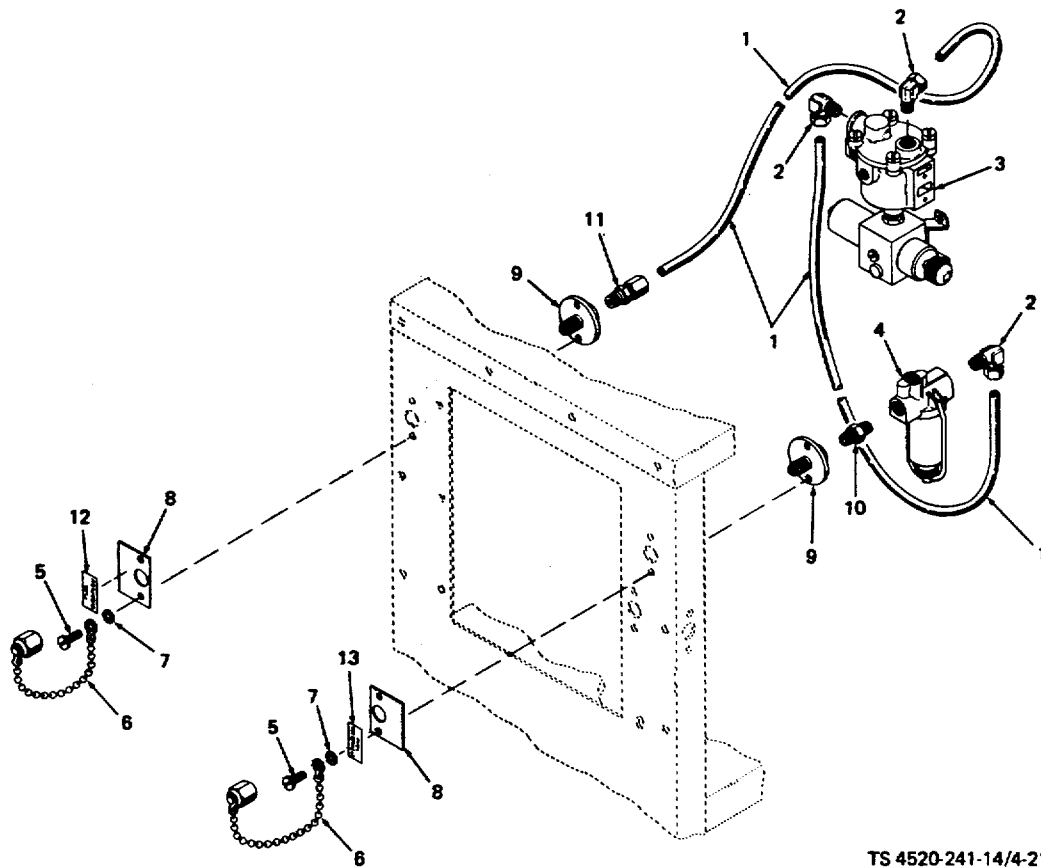

TS 4520-241-14/4-21

- | | |
|----------------|---------------------------|
| 1. Tubing | 8. Receptacle plate |
| 2. Male elbow | 9. Bulkhead fitting |
| 3. Carburetor | 10. Nipple |
| 4. Fuel filter | 11. Male connector |
| 5. Screw | 12. FUEL OVERFLOW decal |
| 6. Seal cap | 13. FUEL RECEPTACLE decal |
| 7. Lock washer | |

Figure 4-21. Fuel lines and fittings.

(6) Unscrew the other bulkhead fitting (9) from the male connector (11), and then loosen the nut on the connector to release the tubing (1).

(7) Replace decals (12) and (13) if they are damaged.

b. Cleaning and Inspection.**WARNING**

Clean parts in a well-ventilated area. Avoid inhalation of solvent fumes and prolonged exposure of skin to cleaning solvent. Wash exposed skin thoroughly. Dry cleaning solvent (fed. spec. P-D-680) used to clean parts is potentially dangerous to personnel and property. Do not use near open flame or excessive heat. Flash point of solvent is 100°F (38°C).

- (1) Clean the fuel lines and fittings thoroughly in a solvent (P-D-680), and dry completely.
- (2) Inspect all metal parts for damaged threads, obstructions, cracks, or other failure. Replace if necessary.
- (3) Tighten all fittings to stop leaks.

c. Reassembly. Reverse disassembly sequence.**4-31. FUEL FILTER.**a. Disassembly.**WARNING**

This space heater contains dangerous voltages which can cause severe electrical shock. Be sure to disconnect the power plug before repairing the heater.

- (1) Disconnect the power plug and shut off the fuel supply.
- (2) Open the side access doors.
- (3) Loosen the thumb screw on the bail (1, fig. 4-22) and swing the bail to one side.
- (4) Remove the bowl (2), gasket (3), and filter element (4) from filter (5). Pipe plug (6) should not be removed.
- (5) If the entire fuel filter needs replacement, disconnect it from the fuel lines and fittings.

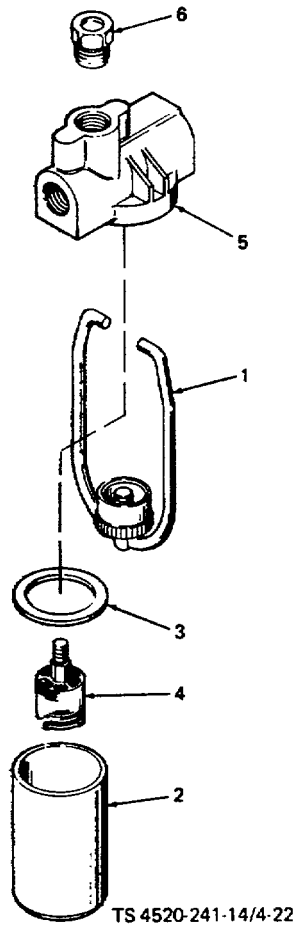

TS 4520-241-14/4-22

- | | |
|-----------|-------------------|
| 1. Bail | 4. Filter element |
| 2. Bowl | 5. Filter head |
| 3. Gasket | 6. Pipe plug |

Figure 4-22. Fuel filter.

b. Cleaning and Inspection.

WARNING

Clean parts in a well-ventilated area. Avoid inhalation of solvent fumes and prolonged exposure of skin to cleaning solvent. Wash exposed skin thoroughly. Dry cleaning solvent (fed. spec. P-D-680) used to clean parts is potentially dangerous to personnel and property. Do not use near open flame or excessive heat. Flash point of solvent is 100°F (38°C).

- (1) Empty the bowl and clean the bowl and filter element thoroughly with an approved solvent (fed. spec. P-D-680).

- (2) Using a cloth dampened with solvent, wipe off the other parts of the filter. Wipe off the gasket with a clean, dry cloth.
- (3) If the filter element is dented or bent, or if it cannot be cleaned, replace it.
- (4) Tighten the pipe plug.
- c. Reassembly. Reverse the disassembly procedure. Be sure to install the gasket before tightening the bail.

4-32. CARBURETOR.

- a. Adjustment. Whenever the fuel type is changed, or the heater is subjected to extremely low ambient temperatures, the carburetor adjustment must be checked.

NOTE

Adjustment can be made directly through the front access door. There is no need to remove panels.

- (1) Connect the room thermostat, external fuel pump, and power supply to the heater. Start the heater and allow it to warm up for a few minutes.
- (2) Turn the fuel needle (25, fig. 4-23) clockwise gently until it is seated.



Do not force the fuel needle. This may damage the fuel orifice and make correct adjustment difficult or impossible.

- (3) Turn the fuel needle counterclockwise one full turn, then turn only in 1/8 turn increments. After each increment inspect the exhaust. The fuel flow should be increased until there is no odor of unburned fuel or any smoke.
- (4) In low ambient temperatures it may be necessary to increase the fuel flow to achieve smooth burner operation.

- b. Removal.



This space heater contains dangerous voltages which can cause severe electrical shock. Be sure to disconnect the power plug before repairing the heater.

- (1) Disconnect the power plug and shut off the fuel supply.

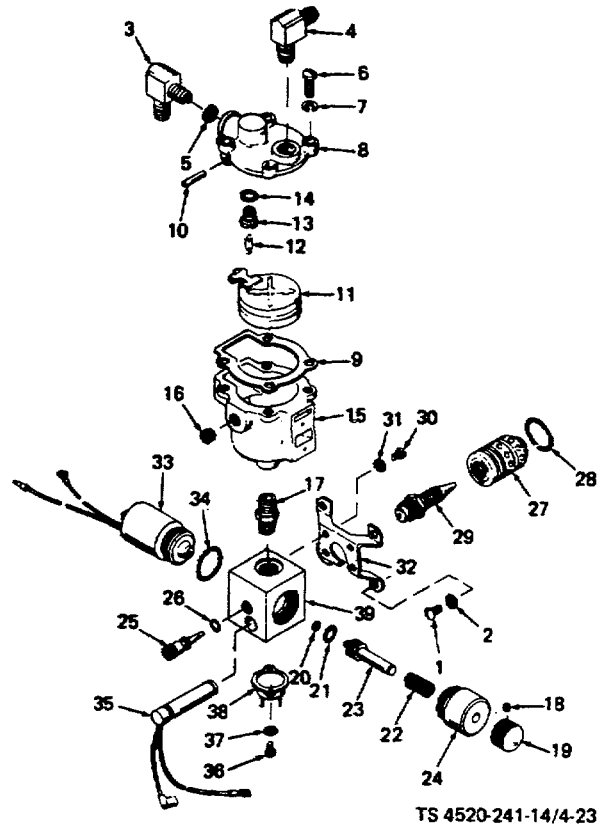

- | | |
|-----------------------|-----------------------|
| 1. Screw | 21. Preformed packing |
| 2. Lock washer | 22. Spring |
| 3. Elbow | 23. Stem |
| 4. Elbow | 24. Choke body |
| 5. Screen | 25. Fuel needle |
| 6. Screw | 26. Preformed packing |
| 7. Lock washer | 27. Fuel mixer |
| 8. Float bowl cover | 28. Preformed packing |
| 9. Gasket | 29. Fuel jet |
| 10. Float pin | 30. Screw |
| 11. Float | 31. Lock washer |
| 12. Needle | 32. Bracket |
| 13. Seat | 33. Solenoid valve |
| 14. Washer | 34. Preformed packing |
| 15. Bowl | 35. Fuel heater |
| 16. Plug | 36. Screw |
| 17. Pipe nipple | 37. Lock washer |
| 18. Set screw | 38. Fuel thermostat |
| 19. Knob | 39. Carburetor body |
| 20. Preformed packing | |

Figure 4-23. Carburetor assembly.

- (2) Disconnect the wires to the solenoid valve, fuel thermostat, and fuel heater. Disconnect the fuel lines.

(3) Remove four screws (1, fig. 4-23) and lock washers (2) to remove the carburetor from the burner. Spill out fuel remaining in the carburetor and dispose of in accordance with current directives for flammable liquids.



Do not attempt to clean the carburetor by applying compressed air to the fuel inlet elbow while the carburetor is assembled. Pressure in the float bowl will collapse the float and may cause other damage.

c. Disassembly.

- (1) Remove elbows (3 and 4), and pull out screen (5) from fuel inlet port.
- (2) Remove four screws (6) and lock washers (7) which secure float bowl cover (8) to bowl (15). Pull off cover and gasket (9).
- (3) Pull out float pin (10) and remove float (11) and needle (12). Unscrew seat (13) and remove washer (14).
- (4) Unscrew bowl (15) and remove pipe nipple (17).
- (5) Unscrew choke body (24) and remove choke assembly from carburetor body (39). Loosen set screw (18) and remove knob (19). Remove preformed packings (20 and 21) and spring (22) from stem (23).
- (6) Unscrew and remove fuel needle (25), and remove preformed packing (26).
- (7) Unscrew fuel mixer (27), and pull off preformed packing (28). Unscrew and remove fuel jet (29).
- (8) Remove screws (30) and lock washers (31) securing bracket (32) to carburetor body, and pull off bracket.
- (9) Remove hex nut at end of solenoid valve (33). Pull off solenoid coil and washer, and unscrew solenoid nut from carburetor body. Remove preformed packing (34) from carburetor body. Do not lose solenoid plunger or return spring.
- (10) Pull out fuel heater (35) from carburetor body. Remove screws (36) and lock washers (37) securing fuel thermostat (38), and remove thermostat.
- (11) Discard all gaskets and preformed packings.

d. Cleaning and Inspection.**WARNING**

Clean parts in a well-ventilated area. Avoid inhalation of solvent fumes and prolonged exposure of skin to cleaning solvent. Wash exposed skin thoroughly. Dry cleaning solvent (fed. spec. P-D-680) used to clean parts is potentially dangerous to personnel and property. Do not use near open flame or excessive heat. Flash point of solvent is 100°F (38°C).

(1) Clean all metal parts with dry cleaning solvent (fed. spec. P-D-680), and allow to dry thoroughly before reassembly. Do not expose preformed packings, solenoid valve, fuel heater, or fuel thermostat to solvent. Clean these parts by wiping with clean cloth.

(2) Inspect the needle and seal for nicks, scratches, and other damage which would prevent a good seal. Replace defective parts.

(3) Inspect the float bowl and cover for cracks, stripped threads, and damage to mating surfaces. Remove minor surface damage with a fine file and emery cloth, but replace parts that cannot be repaired to prevent leakage.

(4) Inspect the carburetor body for stripped threads. Inspect for damage to the surfaces which mate with the fuel needle, solenoid valve, and choke valve. Replace the carburetor body if the threads cannot be restored, or if there is internal damage.

CAUTION

Do not attempt to clean the fuel jet with stiff wire or any hard, sharp object. If the orifice becomes enlarged, proper fuel flow adjustment may be impossible.

(5) Inspect the fuel mixer and fuel jet for clogging, damaged threads, and enlarged or damaged fuel and air flow holes. Clean off carbon buildup with a wire brush. Clean up the threads, if possible, but replace either part if there is damage which could affect fuel flow.

(6) Inspect the fuel heater for continuity with a low voltage test light or ohmmeter. Replace the heater if it is open.

(7) Test the fuel thermostat for continuity. There should be no continuity at $55^{\circ} \pm 6^{\circ}\text{F}$ (9.4° to 16.0°C), but there should be continuity at $40^{\circ} \pm 6^{\circ}\text{F}$ (1.1° to 7.8°C). Replace the thermostat if it does not meet these specifications.

e. Reassembly. Reassemble the carburetor in the reverse order of disassembly. Note the following:

(1) When installing the fuel needle (25, fig. 4-23), lubricate preformed packing (26) with fluorosilicone conforming to MIL-G-27617.

(2) Float bowl (15) must be aligned with the carburetor body as shown in the exploded view to facilitate connection of the fuel lines.

f. Installation. Installation of the carburetor is the reverse of removal.

4-33. SOLENOID VALVE.

a. Testing. The solenoid valve, which screws into the carburetor body, is not repairable. Test it by connecting the two leads to a 24-VDC power source. When the solenoid valve is energized and deenergized, the mechanical sound of the valve opening or closing should be heard as a "click". If there is no evidence of the valve operating, replace it.

b. Replacement.

(1) Open the front access door. Remove nut (1, fig. 4-24) and pull off solenoid coil (2) and washer (3).

(2) Use an adjustable, open-end wrench to unscrew and remove nut (4). Do not lose spring (8). Only the preformed packing (6) is replaceable separately. If any other part of the solenoid valve is defective, replace the solenoid valve as an assembly.

(3) To install a new solenoid valve, be sure spring (8) is installed in the plunger. Screw the nut into the carburetor body, and tighten with an adjustable wrench.

(4) Install washer (3) and solenoid coil (2) over the stem (5). Fit the black coil lead over the threaded end of the stem, and connect the yellow lead to the electrical connector. Retain the coil by installing nut (1).

NOTE

Be sure to tighten nut (1) securely. It regulates the travel of plunger (7).

(5) Close the access door and check the heater for proper operation.

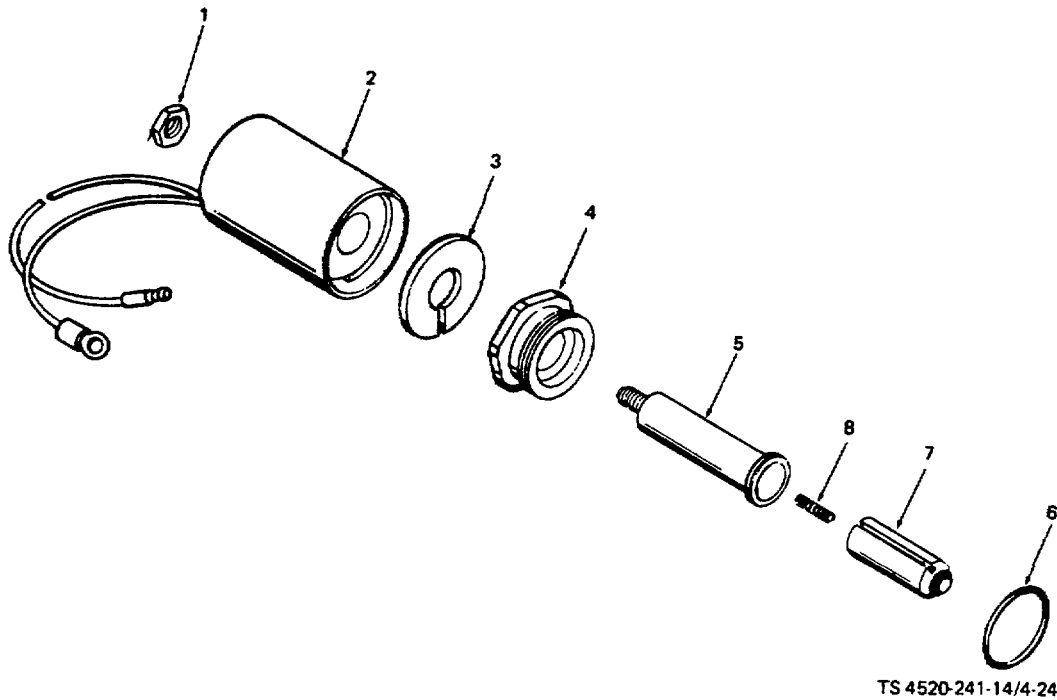

- | | |
|-----------|----------------------|
| 1. Nut | 5. Stem |
| 2. Coil | 6. Preformed packing |
| 3. Washer | 7. Plunger |
| 4. Nut | 8. Spring |

Figure 4-24. Solenoid assembly.

SECTION X. MAINTENANCE OF ELECTRICAL SYSTEM

4-34. DESCRIPTION.

a. Wiring Harness. The wiring harness simplifies electrical connections inside the heater case. The female receptacle accepts the male plug from the control box wiring harness. Leads go to the power and external fuel pump receptacles at one end, and to the terminal board and other electrical components at the other end.

b. Combustion Motor. The combustion motor furnishes a steady supply of fresh air through the air duct directly to the burner head.

c. Ventilating Motor. The ventilating motor forces fresh, cool air across the heat exchanger to provide warm ventilating air.

d. Safety Thermostats. There are four safety thermostats. One is on the combustion motor to prevent it from overheating, and three are in the heat exchanger compartment. The flame switch can also be regarded as a safety thermostat since it will not permit normal heater operation until proper ignition occurs.

e. Fuel Pump Power Supply. The fuel pump power supply rectifies the 120 VAC lines current to 24 VDC to operate both the solenoid and the external fuel pump.

4-35. DESCRIPTION OF ELECTRICAL SYSTEM OPERATION.

a. Startup.

(1) One hundred twenty VAC power is applied to the heater through the POWER RECEPTACLE, through circuit breaker CB1, and through normally closed reset switch S1. See figure 4-25.

(2) As soon as HEATER-OFF-FAN switch S2 is moved to HEATER, white indicator DS2 is illuminated and power is applied to terminal A of ROOM THERMO receptacle J2, and through fuel thermostat S7 to the cartridge heater HR1 in the carburetor body. If the ambient temperature is less than approximately 40°F (4°C), the fuel heater will be energized to preheat the carburetor body and hence the fuel flowing through it.

(3) As long as the temperature of the enclosure is less than the temperature set on the room thermostat, the thermostat contacts will be closed, applying 120 volts to the fuel circuit and to the flame switch. Overheat thermostats S5 and S6 are normally closed as long as the temperature of the heat exchanger remains within safe limits, and 24 VDC power from the fuel pump power supply (transformer T2 and rectifier CR1) is applied to carburetor solenoid valve L1 and through EXTERNAL FUEL PUMP RECEPTACLE J4 to the external fuel pump (not supplied with the heater).

(4) Before the burner ignites, the flame switch S3 is cool, and is in its normally closed position. The normally closed contacts apply 120 volts power from the room thermostat to combustion motor B2 (through suppression capacitors C1 and C2 and thermal cutout S4) and to ignition transformer T1, which supplies high voltage for spark at igniter E1 in the burner. Normally closed flame switch contacts also apply 120 volts to time delay transformer T3. The output of this transformer is rectified by CR2, and the resulting DC voltage is applied to the bimetal heater/sensor HR in the time delay assembly to time the ignition sequence.

b. Transition.

(1) The electrical operation described above ensures that fuel, combustion air, and spark are available in the burner. Under most conditions, the heater will ignite normally within 60 to 90 seconds, and the flame switch S3 will transfer from its normally closed to its normally open contacts.

(2) The time delay assembly times this ignition sequence, and will shut down the heater if the burner fails to ignite within the allotted time. Bimetal heater/sensor HR2 begins to heat as soon as S2 is moved to HEATER (as described above). Reset switch S1 is thermally operated by the heat produced by HR2, so that if HR2 continues to heat, S1 will open to disconnect power from the operating circuits, and to cause red indicator DS1 to light.

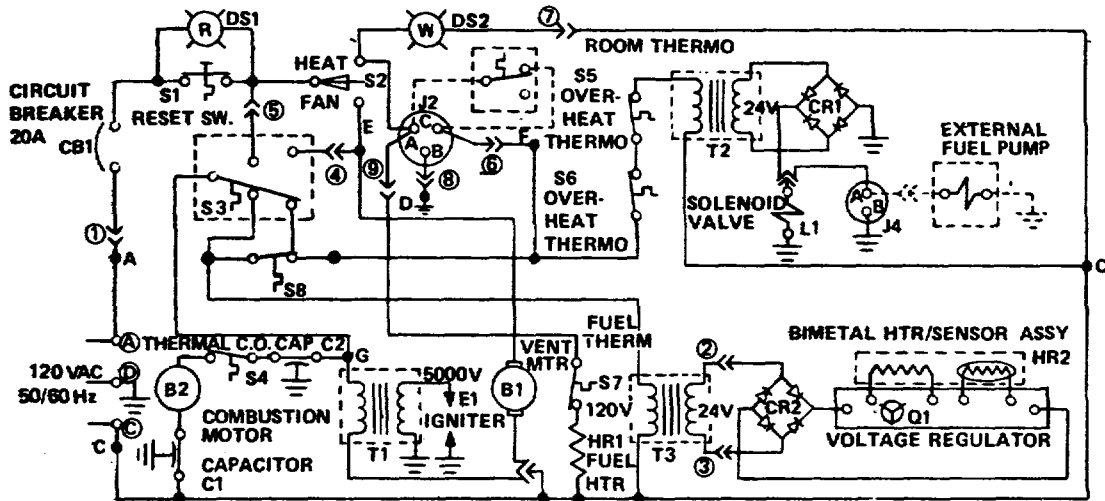

KEY	ITEM	KEY	ITEM	KEY	ITEM
B1	Ventilating motor	E1	Igniter	S2	Toggle switch (HEATER-OFF-FAN)
B2	Combustion motor	HR1	Fuel heater	S3	Flame switch
C1	Capacitor, interference suppression	HR2	Bimetal heater/sensor (Time delay)	S4	Thermal cutout switch
C2	Capacitor, interference suppression	J2	ROOM THERMO receptacle	S5	Overheat thermostat switch
CB1	Circuit breaker, 20 amps	J4	EXTERNAL FUEL PUMP RECEPTACLE	S6	Overheat thermostat switch
CR1	Rectifier (Fuel pump power supply)	L1	Solenoid valve	S7	Fuel thermostat switch
CR2	Rectifier (Time delay)	P1	Male plug (Control box) (see 2, fig. 4-15)	S8	Safety switch
DS1	Incandescent lamp (Red)	Q1	Transistor	T1	Ignition transformer
DS2	Incandescent lamp (White)	S1	Switch, SPST (RESET)	T2	Fuel pump power supply transformer
				T3	Time delay transformer

TS4520-241-14/4-25

Figure 4-25. Electrical system operation.

(3) When ignition occurs, and the flame switch senses the proper temperature in the heat exchanger, the flame switch will trip to its running position (closing the normally open contacts). This action deenergizes HR2 and the time delay assembly, and energizes ventilating motor B1 which forces air from the enclosure past the heat exchanger. Note that the 120 volt input to the flame switch is ahead of switch S2, and so permits heater purge further described in paragraph d.

(4) Safety switch S8 is a safety thermostat which duplicates the item delay circuit functioning of the flame switch. S8 always opens before the flame switch transfers on heat rise, and always closes more slowly on heat shut down. If for any reason the flame switch should fail to close following a combustion failure, this switch will reclose and energize the time delay shutdown circuit to protect the heater from damage.

c. Running.

(1) When the flame switch is in the running position described above, the heater is in the normal running state. Power to the fuel circuit is controlled by the room thermostat, and power to both motors and the ignition transformer is obtained through the flame switch.

(2) In this condition, the room thermostat starts and stops fuel flow to the burner to control the temperature in the enclosure. When the air temperature in the enclosure reaches the temperature set on the thermostat, the thermostat contacts open, deenergizing the carburetor solenoid valve L1 and the external fuel pump. The combustion motor, ventilating motor, and ignition transformer remain energized through the flame switch.

(3) When the air temperature in the enclosure drops below the thermostat setting, the thermostat contacts close, energizing the fuel circuit, and combustion resumes. The heater will normally continue to cycle under control of the room thermostat as long as fuel and power are available.

(4) During this cycling, if the fuel circuit remains deenergized long enough for the burner to cool

d. Shutdown

(1) When the HEATER-OFF-FAN switch S2 is moved to OFF, the fuel circuit is immediately deenergized, stopping fuel flow to the burner head. As noted in paragraph b., the flame switch continues to supply power to both blower motors and to the ignition transformer.

(2) The continuing spark and combustion air flow ensure the combustion of any residual fuel, and ventilating air flow scavenges heat from the heat exchanger. When the temperature of the heat exchanger falls below the flame switch setting, the flame switch trips, deenergizing both motors and the ignition transformer.

e. Overheat.

(1) If the heater overheats because of a reduced supply of ventilating air, excessive fuel flow or other cause, one or both overheat thermostats (S5 and S6) will function.

(2) Both thermostats are designed to open at 270°F (132°C). When the thermostats open, the solenoid valve and fuel pump are deenergized and fuel flow stops.

(3) The ventilating motor and combustion motor will continue to run to cool the heater. When the overheat thermostat which opened senses a temperature of 245°F (118°C), it will close, and fuel will again be available to continue normal running.

(4) The thermal cutout switch (S4) protects the combustion motor from thermal overload. It opens at 223°F (106°C) to deenergize the motor, and closes at 144°F (62°C) to reestablish combustion air flow.

4-36. WIRING HARNESS.

a. Removal.

WARNING

This space heater contains dangerous voltages which can cause severe electrical shock. Be sure to disconnect the power plug before repairing the heater.

(1) Disconnect the power plug from the power receptacle.

(2) The wiring harness is not repairable at the organizational level. To remove it for replacement with a new harness, remove one of the two louver panels. Also remove the control box from the heater case by turning the two studs counterclockwise. Unplug the wiring harness.

(3) Remove nuts (1), (1, fig. 4-26), lock washers (2), and screws (3) to remove the female receptacle (4) from the heater case. Leave all wires attached.

(4) If filter and receptacle assembly (8) must be replaced, remove screws (5), lock washers (6), and dust cap and chain (7) and remove the assembly from the heater case. Disassemble the receptacle and unsolder the wires.

(5) If fuel pump receptacle (13) must be replaced, remove nuts (9), washers (10), dust cap and chain (11), and screws (12), and remove the receptacle from the heater case. Disassemble the receptacle and unsolder the wires.

(6) Disconnect the ten wires from their connecting points as indicated in the wiring diagram inside the right side access door. Tag all leads to aid in reassembly. Carefully pull the wires through the grommet in the heater case one at a time, to avoid damaging the terminals or breaking the wire/terminal board.

b. Replacement. Install in the reverse order of removal. Be sure that all wires are securely fastened to their respective terminals. Spray soldered joints with a moisture repellent conforming to MIL-V-173 (Columbia Technical Humi-Seal, No. 1A27, Class A, or equivalent).

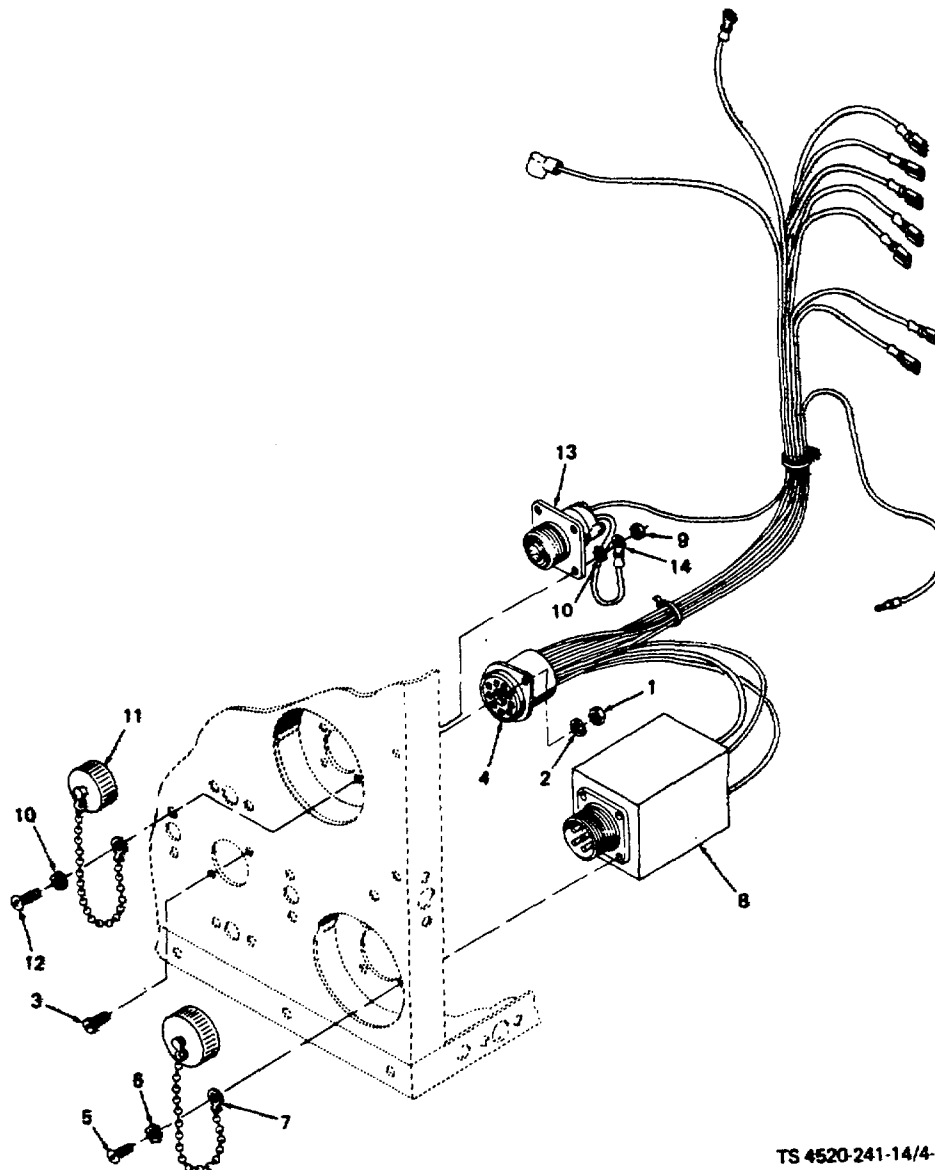

TS 4520-241-14/4-26

- | | |
|-----------------------|-----------------------------------|
| 1. Nut | 8. Filter and receptacle assembly |
| 2. Lock washer | 9. Nut |
| 3. Screw | 10. Lock washer |
| 4. Female receptacle | 11. Dust cap and Chain |
| 5. Screw | 12. Screw |
| 6. Lock washer | 13. Fuel pump receptacle |
| 7. Dust cap and chain | 14. Green lead |

Figure 4-26. Wiring harness.

4-37. SAFETY THERMOSTATS.a. Removal.**WARNING**

This space heater contains dangerous voltages which can cause severe electrical shock. Be sure to disconnect the power plug before repairing the heater.

- (1) Disconnect the power plug from the power receptacle.
- (2) Open either the right or left side access door to gain access to the overheat thermostats. Remove the combustion air duct for access to the lower thermostat.
- (3) Remove the bracket (1, fig. 4-27) which holds the lower thermostat inside the heat exchanger compartment by removing screws (2) and lock washers (3).
- (4) Pull the bracket out of the heater bulkhead. Pull off safety switch (4) and gasket (5). Remove thermostat (9) by removing nuts (6), washers (7), and screws (8).

NOTE

Only the overheat thermostat mounted above the burner has a shield.

- (5) Remove bracket (11) by removing screws (12) and washers (13). Pull the bracket out of the heater bulkhead. Remove thermostat (18) by removing nuts (14), washers (15), shield (16), and screws (17).
- (6) If either grommet (10 or 19) is cracked or damaged, pry it out with a screwdriver and replace it. Tag and disconnect the wires to the flame switch (27).
- (7) Remove screw (20), lock washer (21), and flat washer (22) to remove the assembled flame switch from the heater case. Pull the switch out carefully to avoid damage to the flame switch tube.
- (8) Remove screws (23), lock washers (24), and washers (25) to remove mounting base (26) from flame switch (27).

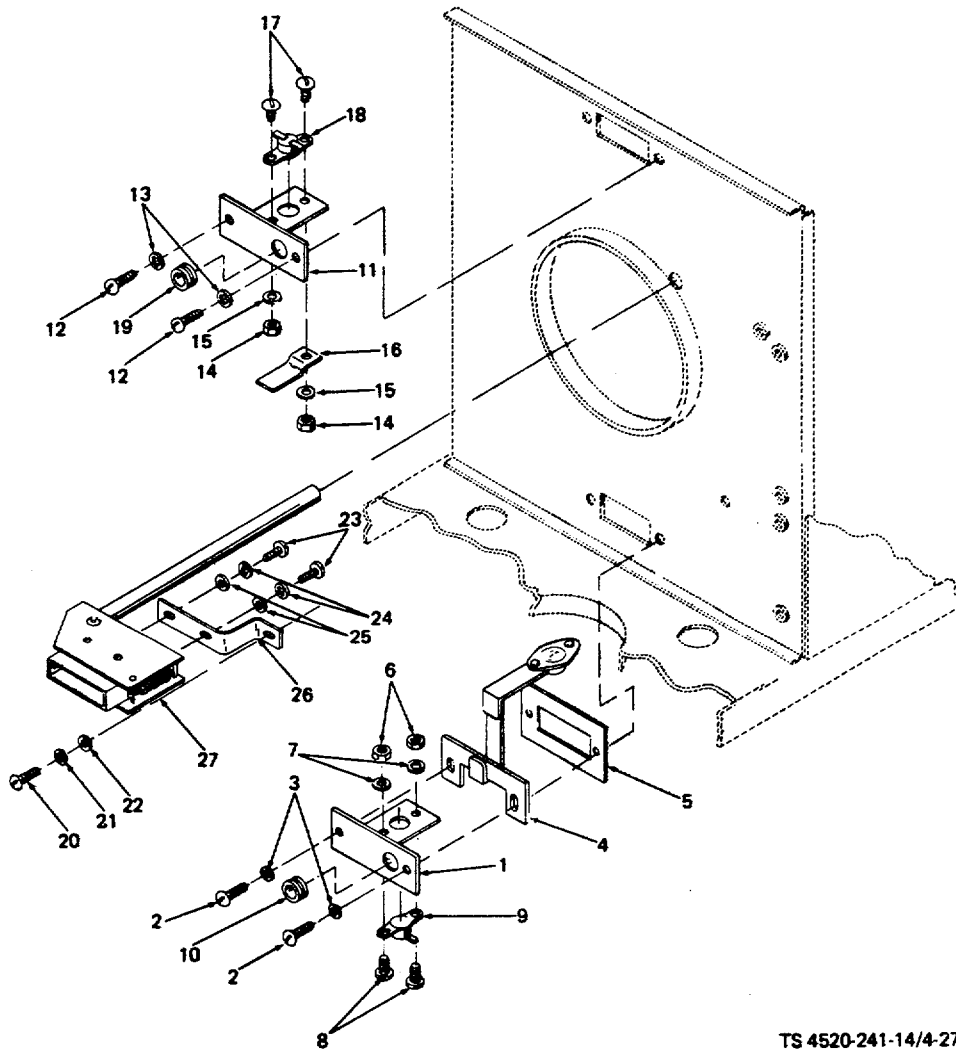

TS 4520-241-14/4-27

- | | |
|------------------|-------------------|
| 1. Bracket | 15. Washer |
| 2. Screw | 16. Shield |
| 3. Lock washer | 17. Screw |
| 4. Safety switch | 18. Thermostat |
| 5. Gasket | 19. Grommet |
| 6. Nut | 20. Screw |
| 7. Washer | 21. Lock washer |
| 8. Screw | 22. Washer |
| 9. Thermostat | 23. Screw |
| 10. Grommet | 24. Lock washer |
| 11. Bracket | 25. Washer |
| 12. Screw | 26. Mounting base |
| 13. Lock washer | 27. Flame switch |
| 14. Nut | |

Figure 4-27. Safety thermostats and flame switch.

b. Cleaning and Inspection.**WARNING**

Clean parts in a well-ventilated area. Avoid inhalation of solvent fumes and prolonged exposure of skin to cleaning solvent. Wash exposed skin thoroughly. Dry cleaning solvent (fed. spec. P-D-680) used to clean parts is potentially dangerous to personnel and property. Do not use near open flame or excessive heat. Flash point of solvent is 100°F (38°C).

(1) Clean the thermostats and flame switch with a clean, dry cloth. Clean all other parts with dry cleaning solvent (fed. spec. P-D-680) and allow to dry.

(2) Inspect thermostats for cracks, dents, damage, and signs of overheating. Check for loose or broken terminals. Replace any damaged thermostats.

(3) Test the overheat thermostats (9 and 18) by connecting the terminals in series to a multimeter by heat resistance, insulated wires. Place the thermostat in a heating chamber along with an accurate thermometer. Watch the multimeter to determine the point at which thermostat opens. This must be between 263° and 277°F (127° and 136°C). Turn off heat and allow the thermostat to cool. It should close between 237° and 253°F (114° and 123°C). Replace the thermostat if it fails to operate within these limits.

(4) Test safety switch (4) in a similar manner. Connect the switch terminals in series to a multimeter. Place the switch in a heating chamber with an accurate thermometer. The thermostat must be open at approximately 110°F (43°C). Turn off the heat and allow the thermostat to cool. It should close at approximately 92°F (33°C). Replace the thermostat if it fails to open and close at these temperatures.

c. Installation. Installation is essentially the reverse of removal. Refer to figure 4-27 and note the following:

(1) If heater is mounted with discharge outlet up or discharge outlet down, be sure to install shield (16) on the upper thermostat as shown. Failure to install the shield correctly may cause nuisance operation of the upper thermostat.

(2) If heater is mounted on either flat side, the shield should be mounted on the thermostat farthest from the ventilating motor.

(3) When reinstalling flame switch, be sure that the end of the switch probe engages the bracket on the heat exchanger.

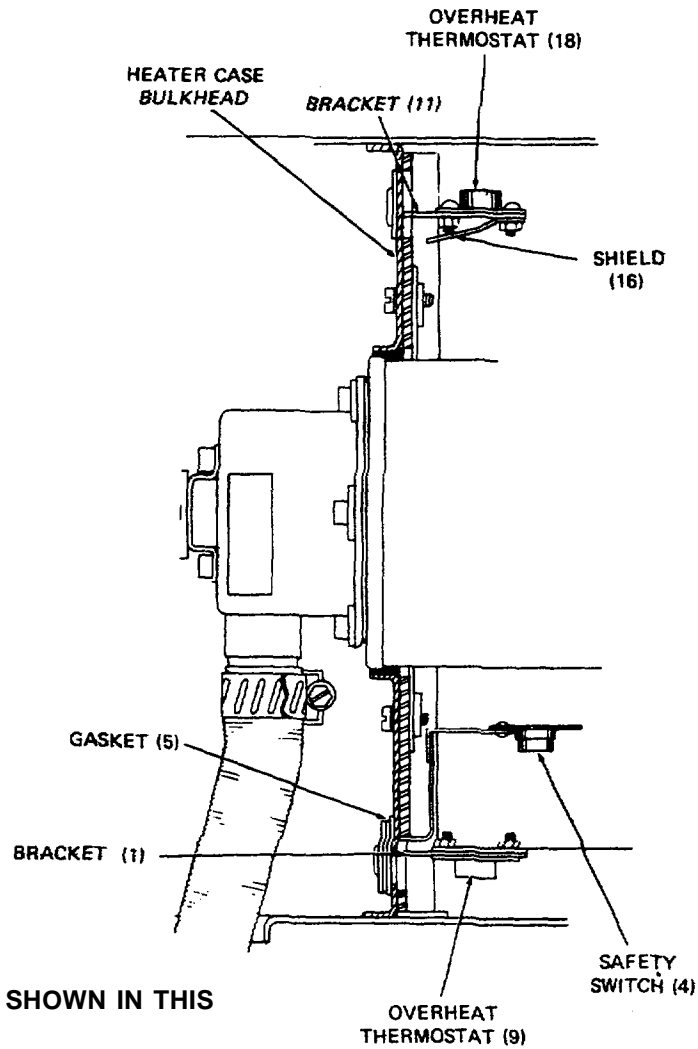

NOTES

1. FLAME SWITCH IS NOT SHOWN IN THIS VIEW.
2. SHIELD (16) MUST BE INSTALLED ON THERMOSTAT MOUNTED ABOVE HEAT EXCHANGER WHETHER HEATER IS MOUNTED WITH DISCHARGE OUTLET UP OR DOWN.
3. NUMBERS IN PARENTHESES CORRESPOND TO ITEM NUMBERS IN FIG. 4-27.

TS 4520-241-14/4-28

Figure 4-28. Thermostat and safety switch installation.

4-38. FUEL PUMP POWER SUPPLY.

a. Removal.

WARNING

This space heater contains dangerous voltages which can cause severe electrical shock. Be sure to disconnect the power plug before repairing the heater.

- (1) Disconnect the power plug from the power receptacle.
- (2) Open the side access door.
- (3) Remove the entire fuel pump power supply assembly by removing two screws (1, fig. 4-29), washers (2), and lock washers (3).
- (4) Disconnect the fuel pump power supply electrical leads by pulling the white lead (4) off the terminal strip and the yellow lead (5) out of the connector. The gray lead (6) is connected to the lower overheat thermostat, which must be removed from the bulkhead before pulling off the terminal.

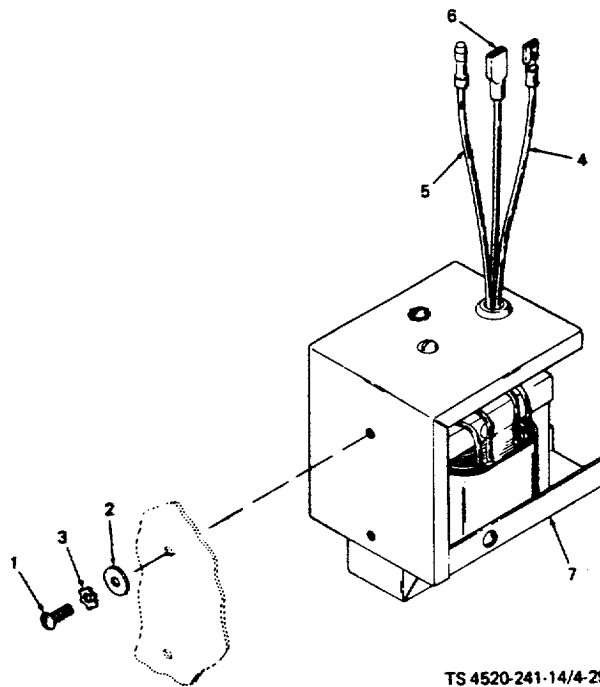

- | | |
|----------------|---------------------------|
| 1. Screw | 4. White lead |
| 2. Washer | 5. Yellow lead |
| 3. Lock washer | 6. Gray lead |
| | 7. Fuel pump power supply |

Figure 4-29. Fuel pump power supply.

- b. Repair. Forward the fuel pump power supply to direct support maintenance for repairs.
- c. Installation. Install in the reverse order of removal, and note the following.

(1) The positive (+) output of the power supply is through the yellow wire, which must be connected to the three-way electrical connector for the carburetor solenoid valve and the EXTERNAL FUEL PUMP RECEPTACLE.

(2) The negative (-) output of the power supply is through the power supply case. Be sure that attaching screws are tightened securely so that there is good electrical contact between the fuel pump power supply bracket and the heater case.

SECTION XI. MAINTENANCE OF BURNER ASSEMBLY

4-39. DESCRIPTION.

- a. Burner Assembly. The burner assembly is the housing where the air and fuel mixture is ignited. No maintenance is authorized at the organizational level.
- b. Ignition Transformer and Cable. The ignition transformer steps up 120 VAC line current to 5,000 VAC to provide a spark at the burner head. This spark is delivered by the igniter which is connected by the cable to the ignition transformer.
- c. Igniter. The igniter consists of an electrode insulated from an outer sleeve. The spark jumps from the electrode to the sleeve.

4-40. IGNITION TRANSFORMER AND CABLE.

- a. Disassembly.



This space heater contains dangerous voltages which can cause severe electrical shock. Be sure to disconnect the power plug before repairing the heater.

- (1) Unplug the power supply cord from the power receptacle.
- (2) Open the front access door, the left and right access doors, and remove the two louvered side panels.
- (3) Remove four nuts (1, fig. 4-30), lock washers (2), and washers (3) to remove ignition transformer (4) from bulkhead (5).
- (4) Disconnect the brown lead (6) from the terminal board and the white lead (7) from the connector.

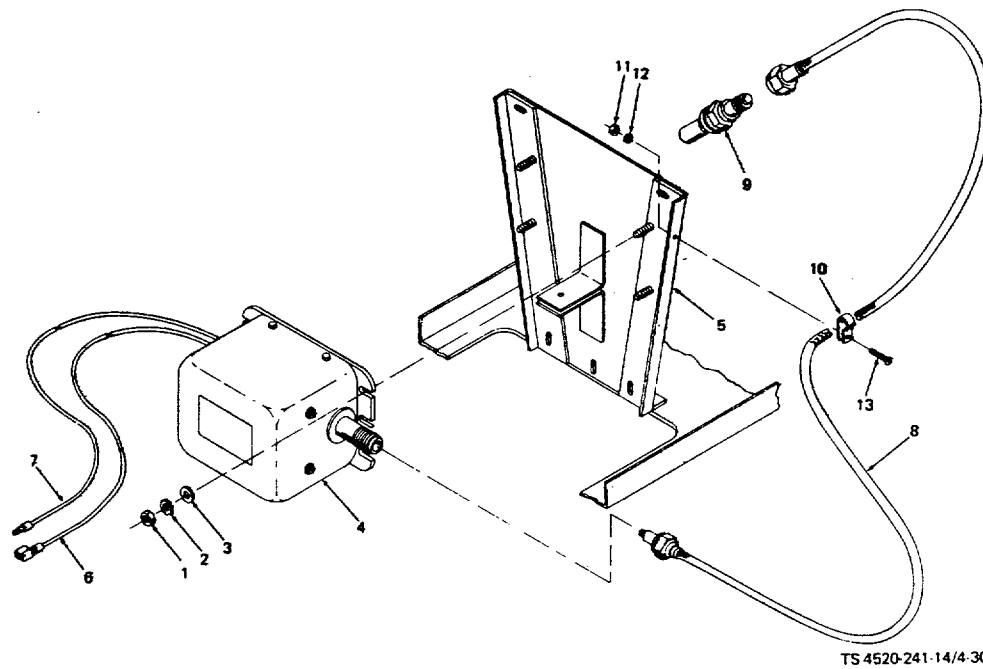

TS 4520-241-14/4-30

- | | |
|-------------------------|-------------------|
| 1. Nut | 8. Ignition cable |
| 2. Lock washer | 9. Igniter |
| 3. Washer | 10. Clamp |
| 4. Ignition transformer | 11. Nut |
| 5. Bulkhead | 12. Lock washer |
| 6. Brown lead | 13. Screw |
| 7. White lead | |

Figure 4-30. Ignition transformer and cable.

(5) If the ignition cable (8) only requires checking, but the ignition transformer must be replaced, unthread the ignition cable at each end. The cable is attached to the transformer by a threaded connector and to the igniter (9) by a threaded compression nut.

(6) If the ignition cable must be removed, disconnect clamp (10) from bulkhead (5) by removing nut (11), lock washer (12), and screw (13). Work out of its hole the grommet that protects the ignition cable as it passes through the heater case. The grommet is split to facilitate removal and installation. Pull out the grommet and feed the cable through the hole.

b. Cleaning and Inspection.**WARNING**

Clean parts in a well-ventilated area. Avoid inhalation of solvent fumes and prolonged exposure of skin to cleaning solvent. Wash exposed skin thoroughly. Dry cleaning solvent (fed. spec. P-D-680) used to clean parts is potentially dangerous to personnel and property. Do not use near open flame or excessive heat. Flash point of solvent is 100°F (38°C).

(1) Wipe the electrical leads and the outside of the ignition transformer with a cloth dampened in dry cleaning solvent (fed. spec. P-D-680).

(2) Clean all non-electrical parts in cleaning solvent and dry thoroughly.

(3) If the ignition transformer shows signs of overheating or malfunctioning, replace it.

(4) Use a multimeter to check for continuity across both the primary and secondary winding of the transformer. When checking secondary windings, check across the insulated output contact and unpainted surface of the heater case. Continuity must exist across both sets of windings.

(5) Inspect the contact springs and wire terminations at each end of the ignition cable. The wires in the ignition cable are flared back around a hollow eyelet which retains the contact spring. Check that the small brad retains the wires where they pass through the eyelet. Poor contact causes arcing, heat buildup, and other problems. Replace the cable if it is damaged, or if wire terminations show signs of arcing or looseness.

c. Assembly. Assemble in the reverse order of disassembly, and note the following:

(1) To reinstall the ignition cable, feed one end of the cable up through the heater case shelf toward the igniter. The grommet which protects the cable is split, and can be worked into the hole with the cable in place.

(2) Be sure to tighten the ignition cable securely at the igniter and at the ignition transformer.

4-41. IGNITER.a. Removal.**WARNING**

The ignition system of this space heater contains dangerous voltages which can cause severe electrical shock. Be sure to disconnect the power plug before repairing the heater.

- (1) Open the front and side access doors.
- (2) To remove the igniter (9, fig. 4-30), unscrew the compression nut on igniter cable (8), and remove the cable.
- (3) Remove the igniter from the burner head.

b. Cleaning and Inspection.**WARNING**

Clean parts in a well-ventilated area. Avoid inhalation of solvent fumes and prolonged exposure of skin to cleaning solvent. Wash exposed skin thoroughly. Dry cleaning solvent (fed. spec. P-D-680) used to clean parts is potentially dangerous to personnel and property. Do not use near open flame or excessive heat. Flash point of solvent is 100°F (38°C).

- (1) Clean the igniter with a cloth dampened with an approved cleaning solvent (fed. spec. P-D-680). Remove any whiskers of carbon which may be bridging the gap between tip and outer shell.
- (2) Inspect the tip and outer shell for burning and pitting. Inspect ceramic parts for cracks and breaks. Inspect threads for damage. Replace a defective igniter.
- (3) The electrode must be flush with the end of the igniter, or recessed up to 0.010 inch. Replace the igniter if it exceeds this wear limit.

c. Replacement. Install in the reverse order of removal.

SECTION XII. MAINTENANCE OF ACCESSORY ITEMS**4-42. DESCRIPTION.**

a. Room Thermostat. The room thermostat is mounted remote from the heater, but controls heater operation. It energizes or deenergizes the heater after sensing ambient temperature and comparing it with the thermostat setting. A differential of approximately 2°F is built in so that the heater will not cycle constantly.

b. Side Covers. The two side heater case covers are shipped separately although their mounting hardware is on the heater assembly. The side covers are only used when air intake is through the bottom rather than through the louvers, or when the heater is stored.

4-43. ROOM THERMOSTAT.**WARNING**

This space heater contains dangerous voltages which can cause severe electrical shock. Be sure to disconnect the power plug before repairing the heater.

a. Testing.

(1) Turn off the heater. Disconnect the thermostat cable from the ROOM THERMO receptacle on the side of the heater control box.

(2) Loosen the screw at the bottom of the room thermostat cover, and pull off the cover for access to the switch inside.

(3) Slowly rotate the knob back and forth. You should be able to detect a distinct click as the dial is rotated past the ambient temperature, as long as the ambient temperature is within the thermostat range.

(4) If you cannot detect a click, use a self-powered test light or an ohmmeter to check continuity across the switch terminals as you rotate the knob. There should be no continuity when the thermostat is set above ambient temperature by 2° or more, and continuity when it is set below ambient temperature by 2° or more.

b. Replacement. No repair of the thermostat is possible. If it does not operate as described above, replace as follows:

(1) Disconnect the thermostat cable from the ROOM THERMO receptacle on the side of the heater control box.

(2) Loosen the screw at the bottom of the thermostat cover, and pull off the cover for access to the wire connections.

(3) Disconnect the cable wires from the thermostat switch. Remove the attaching hardware used to secure the thermostat to the enclosure wall. Disconnect the ground lead from the thermostat, and remove the thermostat.

(4) Installation of a new thermostat is the reverse of removal. Be sure to use 16-gauge, 3-wire (red, black, green) electrical cable per MIL-W-16878D. Ground the cable shield to the room thermostat mounting screws.

CHAPTER 5

DIRECT SUPPORT AND GENERAL SUPPORT MAINTENANCE INSTRUCTIONS

SECTION I. REPAIR PARTS, SPECIAL TOOLS, AND EQUIPMENT

5-1. TOOLS AND EQUIPMENT.

The equipment issued with the space heater is illustrated in figure 1-1.

5-2. SPECIAL TOOLS AND EQUIPMENT.

No special tools or equipment are required for direct support or general support maintenance of the heater.

5-3. MAINTENANCE REPAIR PARTS.

Repair parts and equipment are listed and illustrated in the repair parts and special tools list covering direct support and general support maintenance for the equipment. Refer to TM 4520-241-24P.

SECTION II. TROUBLESHOOTING

5-4. GENERAL.

a. This section contains troubleshooting information for locating and correcting most of the operating malfunctions which may develop in the heater. Each malfunction is followed by a list of tests or inspections which will help you determine probable causes and corrective actions to take. Perform the tests/inspections and corrective actions in the order indicated.

b. This manual cannot list all malfunctions that may occur, nor all tests or inspections and corrective actions. If a malfunction is not listed or is not corrected by listed corrective actions, notify your supervisor. Only those functions that are solely within the scope of direct support and general support maintenance are listed.

5-5. DIRECT SUPPORT AND GENERAL SUPPORT MAINTENANCE TROUBLESHOOTING CHART.

Refer to Table 5-1 for troubleshooting which is allocated to direct support and general support maintenance levels.

WARNING

This space heater contains dangerous voltages which can cause severe electrical shock. Be extremely careful when making voltage measurements or other checks with the heater connected to the power source during troubleshooting. Always remove the power plug before making any continuity tests.

NOTE

Before you use this table, be sure you have performed all applicable operating checks. This table assumes that all applicable operator/crew and organizational maintenance troubleshooting performed, but the cause of the malfunction has not been located.

Table 5-1. Direct Support and General Support Troubleshooting

MALFUNCTION

TESTING OR INSPECTION

CORRECTIVE ACTION

1. HEATER FAILS TO IGNITE AND RED INDICATOR LIGHT COMES ON.

Step 1. Check for combustion air. If the combustion motor seems to run, disconnect the air duct by loosening the clamp at the burner and disconnecting the duct. Move the HEATER-OFF-FAN switch to HEATER. There must be a distinct flow of air.

If there is air flow, proceed to step 2. If there is no air flow, proceed to step 4.

Step 2. Check adjustment of the time delay assembly. Disconnect the power plug. Open the access doors. Open the control box cover. Disconnect the yellow lead from the output of the fuel pump power supply transformer so that no power is applied to the carburetor solenoid valve or to the external fuel pump. Disconnect the brown lead at terminal strip terminal G to disconnect the ignition transformer.

Table 5-1. Direct Support and General Support Troubleshooting - Continued

MALFUNCTION	TESTING OR INSPECTION	CORRECTIVE ACTION
-------------	-----------------------	-------------------

1 - Continued

Connect the power plug. Press the RESET button to clear the switch. Using a stopwatch or a clock with a sweep second hand, move the HEATER-OFF-FAN switch to HEATER and start timing.

The bimetallic heater-sensor must trip the RESET switch within 60 to 90 seconds at an ambient temperature between 65° and 75°F (18° to 24°C). If the time delay operates within this range, no adjustment is required. Reconnect the wires and go to step 3.

If the time delay is outside the specified range, adjust the bimetallic heater/sensor by turning the slotted head screw that moves the end of the sensor closer to or farther from the reset switch. If the time delay was too short, turn the screw counterclockwise 1/4 turn, and retest as described above. If the time was too long, turn the screw clockwise 1/4 turn and retest.

When the adjustment is correct, turn off the power and disconnect the power plug. Reconnect the brown lead to terminal G, and the yellow lead to the electrical connector. Close the control box cover. Check the beater for proper operation.

Step 3. Inspect the burner head. Disconnect the power plug and open the access doors. Disconnect the ignition cable from the igniter, and remove the igniter from the burner head. Disconnect the fuel lines at the elbows on the carburetor. Remove the screws securing the carburetor to the burner head. Pull off the carburetor and move it out of the way. Remove the five screws that secure the burner to the heat exchanger. Pull off the burner and gasket. Inspect the burner head for combustion deposits or debris clogging the combustion air inlet or igniter hole. Check that all internal baffles are in good condition and are securely welded to the burner head. Check for excessive buildup of carbon in the heat exchanger.

Table 5-1. Direct Support and General Support Troubleshooting - Continued

MALFUNCTION	TESTING OR INSPECTION	CORRECTIVE ACTION
1 - Continued		<p>Replace the burner head if it is damaged, or if it cannot be cleaned by wirebrushing to remove combustion deposits. No repairs are authorized. Clean heat exchanger while burner head is removed. Install a new burner head in the reverse order of removal.</p> <p>Step 4. Check for power to the combustion air motor. Turn off the heater power. Remove the louvered panel adjacent to the combustion motor. This should provide sufficient access to the combustion motor terminals to permit a voltage check. Connect an AC voltmeter to the exposed ends of the suppression capacitors on top of the combustion motor assembly. Momentarily move the HEATER-OFF-FAN switch to HEATER. 120 volts AC should be present. Tighten loose connections or replace broken lead if no power is present.</p> <p>Step 5. Check wiring inside combustion motor assembly. Disconnect the power plug, open the access doors, and remove the louvered panels. Disconnect the combustion motor leads at the terminal strip. Remove screw (1, fig. 5-1) and lock washers (2) through support tube (3), and remove support tube. Remove nuts (4) and washers (5, 6, and 7) securing motor assembly to heater case. Disconnect air duct from motor housing (19). Pull out motor assembly. Remove screws (8) and lock washers (9). Separate top motor housing assembly (10) from bottom motor housing assembly (13).</p> <p>Pull out assembled motor housing (19) and combustion motor (32). Remove sealing tape and pry off housing from motor. If necessary, remove nut (14), screw (15), and lock washer (16) to remove ground strap (17). Test continuity through suppression capacitors (23) using test light or ohmmeter.</p> <p>Replace capacitors if they are open. Unsolder wires at capacitor terminals. Remove nuts (21) and washers (22) securing capacitor (23) to motor housing (19). Install new capacitors and resolder wires using rosin core electrical solder. Continue testing per steps 6 and 7 before</p>

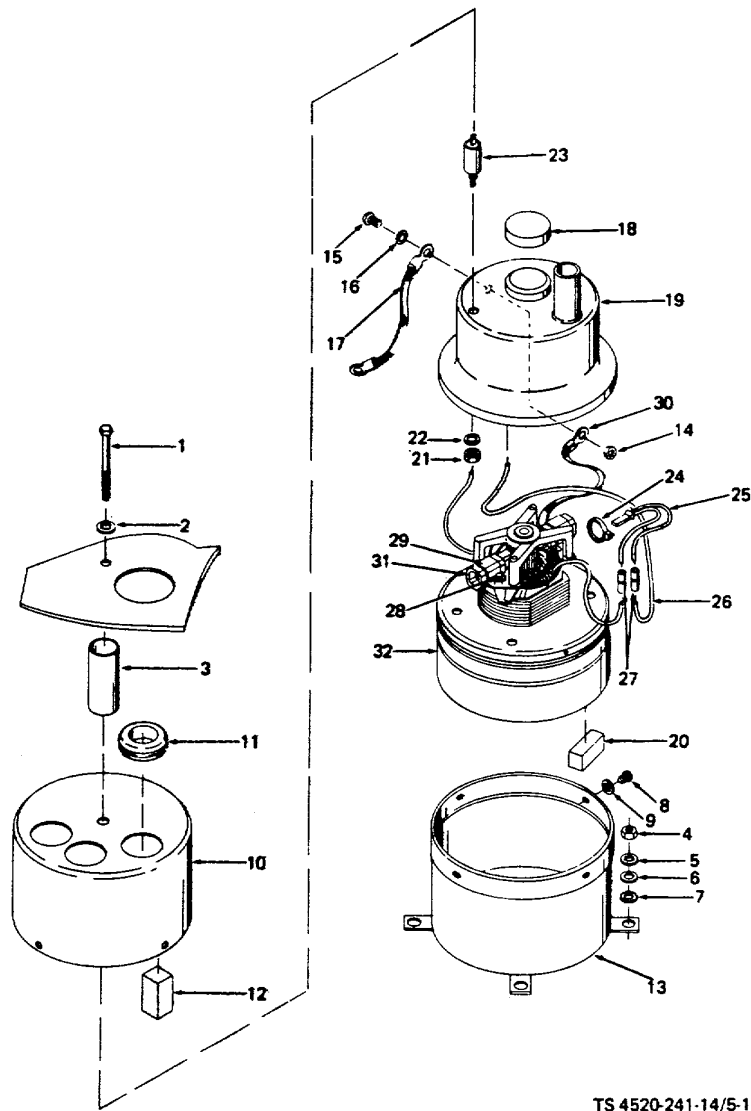

TS 4520-241-14/5-1

- | | |
|-----------------------------------|---------------------------|
| 1. Screw | 17. Ground strap |
| 2. Lock washer | 18. Pad |
| 3. Support tube | 19. Motor housing |
| 4. Nut | 20. Pad |
| 5. Lock washer | 21. Nut |
| 6. Flat washer | 22. Lock washer |
| 7. Lock washer | 23. Suppression capacitor |
| 8. Screw | 24. Ty-rap |
| 9. Lock washer | 25. Thermal cutout |
| 10. Top motor housing assembly | 26. Wire |
| 11. Grommet | 27. Connector |
| 12. Pad | 28. Screw |
| 13. Bottom motor housing assembly | 29. Clamp |
| 14. Nut | 30. Ground strap |
| 15. Screw | 31. Brush assembly |
| 16. Lock washer | 32. Combustion motor |

Figure 5-1. Combustion motor installation.

Table 5-1. Direct Support and General Support Troubleshooting - Continued

MALFUNCTION	TESTING OR INSPECTION	CORRECTIVE ACTION
1 - Continued		<p>reassembling in the reverse order of disassembly.</p> <p>Step 6. Check thermal cutout. Remove and disassemble motor as described in step 5. Check continuity through thermal cutout (25). The internal switch must be closed at room temperature.</p> <p>If the thermal cutout is open, cut the wires at the connectors (27). Cut off Ty-rap (24) securing thermal cutout (25) to the motor field, and discard. Install a new thermal cutout and secure with a new Ty-rap. Connect cutout to motor field with connectors, and crimp connectors to retain. Continue testing per step 7 before reassembling in the reverse order of disassembly.</p> <p>Step 7. Check motor brushes. Remove screws (28) and clamps (29). Inspect brushes (31) for excessive wear, cracks, and other damage.</p> <p>Replace defective brushes. Secure new brushes with clamps (29) and screws (28). Be sure to install ground strap (30) under screw (28) as shown in figure 5-2. Reassemble the motor in reverse of disassembly. Note relationship of parts in figure 5-2. Retain housing (19) by staking to motor (32) with prick punch. Seal notches in motor housing with General Electric RTV-102, or equivalent, and seal the housing-to-motor joint with tape.</p>
	2. HEATER IGNITES, BUT VENTILATING MOTOR FAILS TO RUN.	<p>Step 1. Check motor. Disconnect power plug and open access doors. Remove louvered panel adjacent to ventilating motor. Disconnect white motor lead at electrical connector. Disconnect orange lead at terminal strip. Apply 120 VAC to white and orange motor leads.</p>

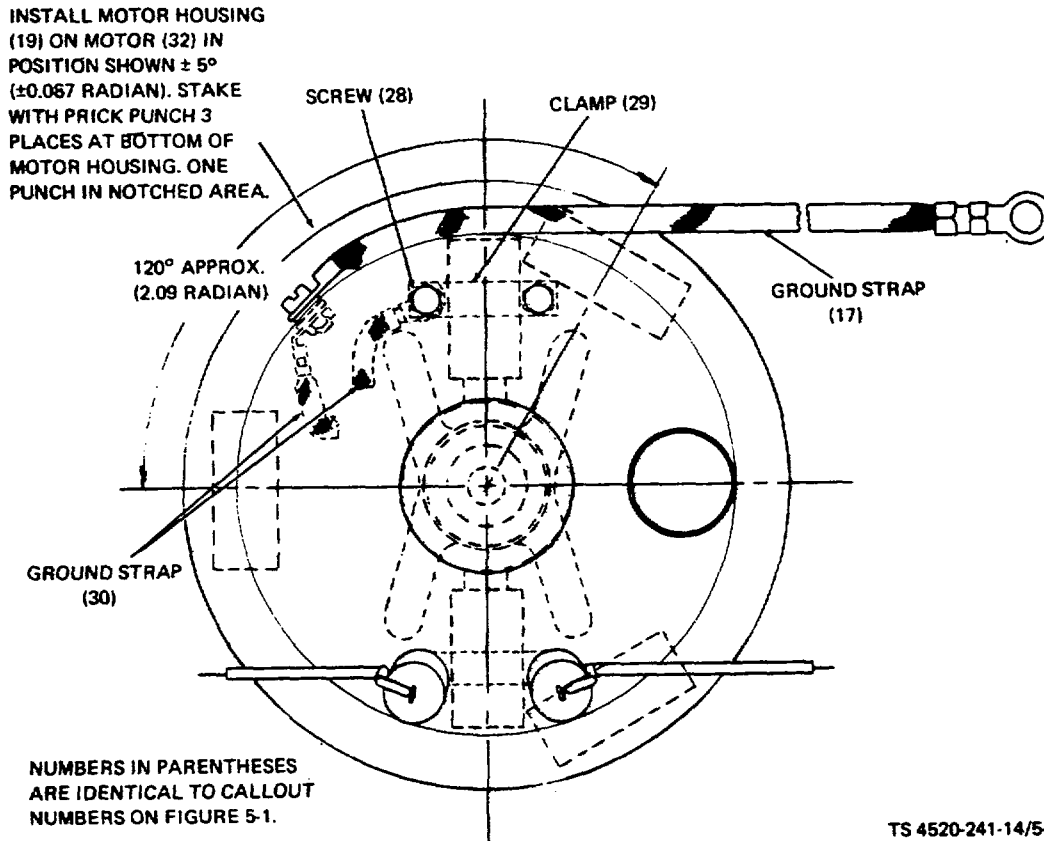

Figure 5-2. Combustion motor assembly relationships.

Table 5-1. Direct Support and General Support Troubleshooting - Continued

MALFUNCTION

TESTING OR INSPECTION

CORRECTIVE ACTION

2 - Continued

If motor fails to run, replace as follows: Remove the ventilating motor along with its mounting bracket by removing screws (1, fig. 5-3) and lock washers (2).

Remove nut (3), lock washer (4), cable clamp (5), lock washer (6), and screw (7) to unfasten one end of grounding strap (21).

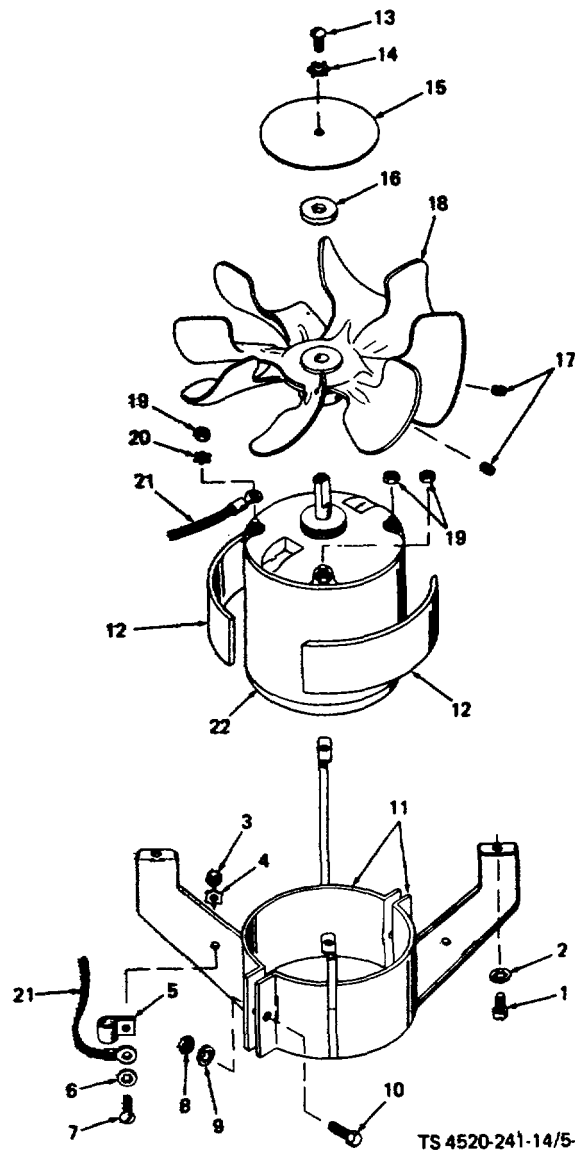

TS 4520-241-14/5-3

- | | |
|----------------------------|-----------------------|
| 1. Screw | 12. Mounting pad |
| 2. Lock washer | 13. Screw |
| 3. Nut | 14. Lock washer |
| 4. Lock washer | 15. Blower disc |
| 5. Cable clamp | 16. Spacer |
| 6. Lock washer | 17. Set screw |
| 7. Screw | 18. Axial fan |
| 8. Nut | 19. Nut |
| 9. Lock washer | 20. Lock washer |
| 10. Screw | 21. Grounding strap |
| 11. Motor mounting bracket | 22. Ventilating motor |

Figure 5-3. Ventilating motor installation.

Table 5-1. Direct Support and General Support Troubleshooting - Continued

MALFUNCTION	TESTING OR INSPECTION	CORRECTIVE ACTION
-------------	-----------------------	-------------------

2 - Continued

Remove nuts (8), lock washers (9), and screws (10) to separate and remove the two motor mounting brackets (11).

Pull the mounting pads (12) off the motor assembly if they are damaged.

Remove screw (13), lock washer (14), blower disc (15), and spacer (16) so that the fan can be removed.

Loosen both set screws (17) and remove axial fan (18).

Remove the one nut (19) and lock washer (20) that secure the grounding strap (21) to the ventilating motor (22).

No repair is authorized. Install a new ventilating motor in the reverse order of removal. Seal around hole for wires using General Electric RTV-102 or equivalent. Slide motor up or down inside brackets (11) to obtain clearance shown in figure 5-4.

3. HEATER BACKFIRES.

NOTE

Operation of the heater with fuels of high volatility can cause popping or backfiring as bubbles of fuel pass through the fuel jet. Certain types of gasoline can cause this. If possible, operate the heater with another type of fuel before proceeding.

- Step 1. Check condition of heat shield washers inside the end of the heat exchanger. Disconnect the power plug, and open the access doors. Disconnect the ignition cable from the igniter, and remove the igniter from the burner head. Disconnect the fuel lines at the elbows on the carburetor. Remove the screws securing the carburetor to the burner head.

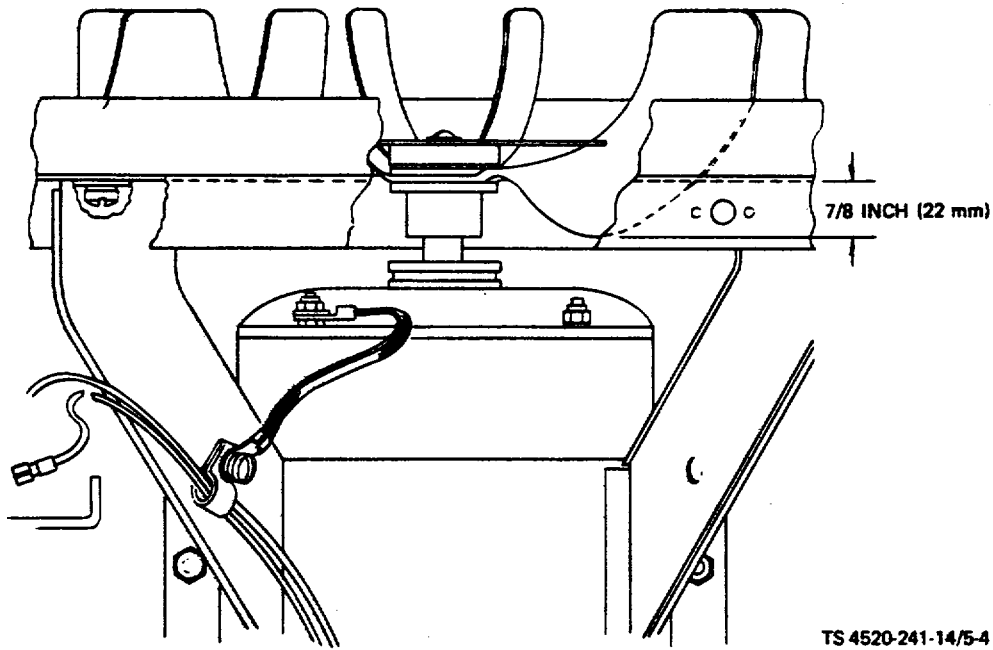

Figure 5-4. Axial fan installation dimension.

Table 5-1. Direct Support and General Support Troubleshooting - Continued

MALFUNCTION

TESTING OR INSPECTION

CORRECTIVE ACTION

3 - Continued

Pull off the carburetor and move it out of the way. Remove the five screws that secure the burner to the heat exchanger. Pull off the burner and gasket. Inspect the six insulators inside the burner end of the heat exchanger. These insulators reduce the transfer of heat to the carburetor so the fuel doesn't percolate. If insulators are in good condition, go to next step. If not, replace them.

Pull out the insulators from the end of the heat exchanger. New insulators are split to facilitate installation.

Table 5-1. Direct Support and General Support Troubleshooting - Continued

MALFUNCTION

TESTING OR INSPECTION

CORRECTIVE ACTION

3 - Continued

Install four insulators with the smaller hole into the heat exchanger, then install the two insulators with the larger hole. See figure 5-5. Reinstall burner head and carburetor.

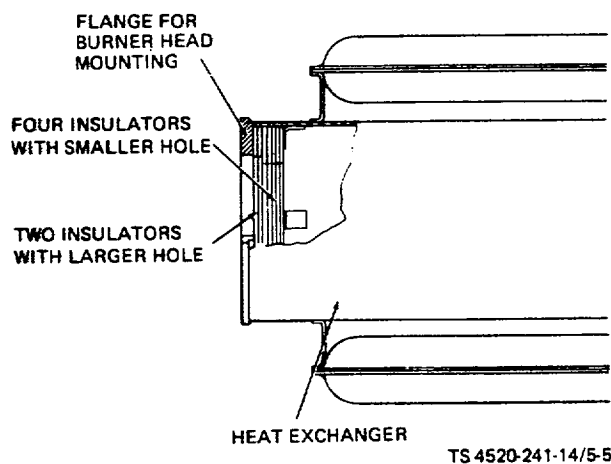

Figure 5-5. Heat exchanger insulator installation.

Step 2. Check combustion motor assembly. Disconnect power plug, open the access doors, and remove the louvered panels. Disconnect combustion motor leads at the terminal strip. Remove screw and lock washers through support tube securing top of motor to heater case. Remove nuts and washers securing base of motor to heater case. Disconnect air duct from motor housing, and pull out motor assembly. Remove screws and lock washers securing top motor housing assembly to bottom motor housing assembly, and separate housings. Remove screws, lock washers, and ground strap, and separate motor housing from motor. Inspect combustion motor for defective armature bearings, or loose fans.

If motor bearings are defective, or fans are loose, correct as follows:

Table 5-1. Direct Support and General Support Troubleshooting - Continued

MALFUNCTION**TESTING OR INSPECTION****CORRECTIVE ACTION**

3 - Continued

There is normally sufficient slack in wires (5 and 6, fig. 5-6) to permit disassembly, but the wires may be unsoldered from suppression capacitors (3) if necessary.

Remove screws (10) and clamps (11), and remove brush assemblies (12).

Remove screws (13) and ground strap (14), and pull off frame cap (15) and loading spring (16). Rotate armature (19) to determine condition of ball bearings (21), and to check that fan assemblies (24 and 27) are tight on armature shaft.

If bearings or armature must be replaced, remove nut (17) and washer (18) from lower end of armature shaft, and pull out armature and bearings. Remove bearings with a puller and press on new bearings. Reassemble in the reverse order of removal, guiding threaded end of armature shaft through assembled housings and fan assemblies (22 through 28).

If fan assemblies are loose, grasp armature and tighten nut (17). If fan assemblies are defective, remove tape that seals upper and lower chambers to housing frame assembly (22). Pry off lower chamber (28). Remove nut (17) and washer (18), and pull off fan assembly (27). Pry off upper chamber (26), and remove spacer spool (25) and fan assembly (24). Reassemble in the reverse order of disassembly.

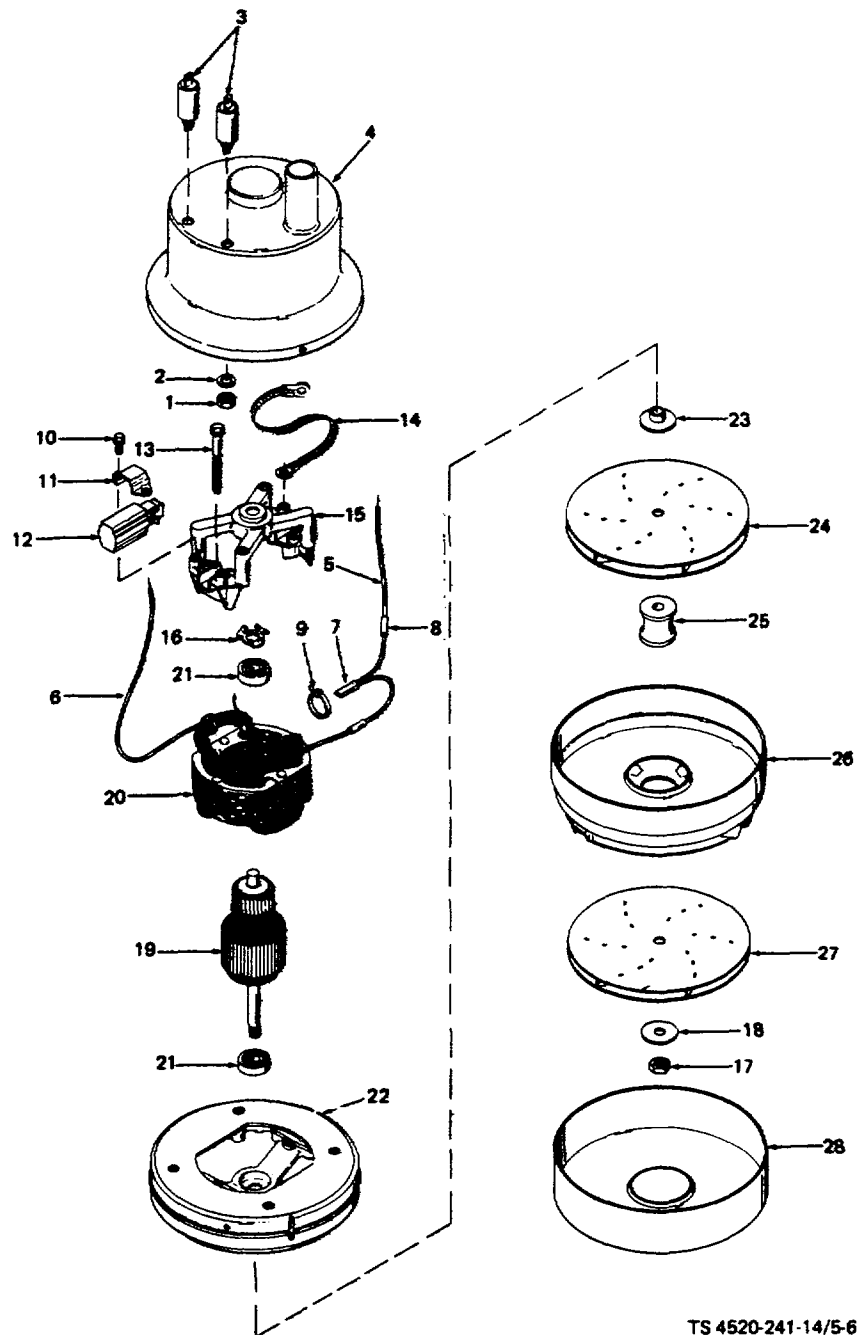

TS 4520-241-14/5-6

Figure 5-6. Combustion motor assembly.

KEY to fig. 5-6:

- | | |
|--------------------------|----------------------------|
| 1. Nut | 15. Frame cap |
| 2. Lock washer | 16. Loading spring |
| 3. Suppression capacitor | 17. Nut |
| 4. Motor housing | 18. Washer |
| 5. Wire | 19. Armature |
| 6. Wire | 20. Field |
| 7. Thermal cutout | 21. Ball bearing |
| 8. Connector | 22. Housing frame assembly |
| 9. Ty-rap | 23. Spacer |
| 10. Screw | 24. Fan assembly |
| 11. Clamp | 25. Spacer spool |
| 12. Brush assembly | 26. Upper chamber |
| 13. Screw | 27. Fan assembly |
| 14. Ground strap | 28. Lower chamber |

Table 5-1. Direct Support and General Support Troubleshooting - Continued

MALFUNCTION

TESTING OR INSPECTION

CORRECTIVE ACTION

4. HEATER FAILS TO IGNITE, BUT RED INDICATOR LIGHT DOES NOT COME ON.

Step 1. Check time delay transformer output. Disconnect power plug. Remove the control box and disconnect male plug. Install a jumper from pin 1 to pin 6 in the female receptacle in the heater case. Open access doors and disconnect the brown lead to the flame switch at terminal strip terminal G. Connect the power plug and measure voltage at pins 2 and 3 of the female receptacle. Voltage should be 23 to 30 VAC.

If there is no voltage, or incorrect voltage, replace the time delay transformer assembly. Disconnect the power plug. Disconnect the 4 leads at the time delay transformer (below the terminal strip near the carburetor). Remove the screws and washers which secure the transformer to the heater case, and remove the transformer. Install a new transformer and secure to the heater case with screws and washers. Connect the four leads and recheck operation. If this corrects the problem, reconnect the brown wire to terminal strip terminal G.

Table 5-1. Direct Support and General Support Troubleshooting - Continued

MALFUNCTION**TESTING OR INSPECTION****CORRECTIVE ACTION**

4 - Continued

Step 2. Test the PC board and transistor assembly. Remove the jumper installed in the female receptacle in step 1. Plug the control box into the female receptacle, and reinstall the control box on the front of the heater case. Set the room thermostat above ambient temperature to ensure that its contacts are closed.

Open the control box cover. Remove nuts (1, fig. 5-7), lock washers (2), and flat washers (3) securing label (4) to the PC board (15). Pull off the label for access to connection points on the board.

Connect the power plug. Perform the following tests to evaluate the condition of the PC board and transistor assembly.



Set up tests and make all test connections before switching the HEATER-OFF-FAN switch to HEATER. All test readings must be made with only momentary actuation of the switch to the HEATER position.

Connect a DC voltmeter to V5 (negative) and to the center pin of the transistor (positive). It may be necessary to scrape away the varnish coating to ensure good contact. (Refer to Appendix D, Expendable Supplies and Materials List.) Momentarily move the switch to HEATER. The voltmeter must read approximately 30 volts. If it reads less than 28 volts, replace the PC board and transistor as an assembly (see below).

Connect the voltmeter to V5 (negative) and V4 (positive). Scrape away the varnish coating if necessary. (Refer to Appendix D, Expendable Supplies and Materials List.) Momentarily move the switch to HEATER. The voltage should be 13 volts. If it is less than 12 volts, replace the transistor. If it is more than 14 volts, replace the PC board and transistor as an assembly.

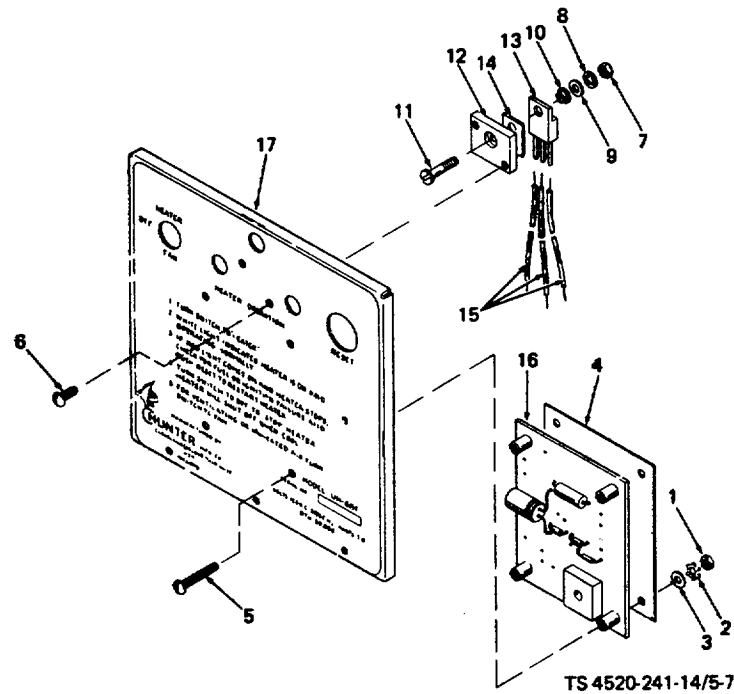

- | | |
|----------------|-----------------------|
| 1. Nut | 10. Shoulder washer |
| 2. Lock washer | 11. Screw |
| 3. Flat washer | 12. Heat sink |
| 4. Label | 13. Transistor |
| 5. Screw | 14. Insulator |
| 6. Screw | 15. Wires |
| 7. Nut | 16. PC board |
| 8. Lock washer | 17. Control box cover |
| 9. Washer | |

Figure 5-7. PC Board and transistor installation.

Table 5-1. Direct Support and General Support Troubleshooting - Continued

MALFUNCTION

TESTING OR INSPECTION

CORRECTIVE ACTION

4 - Continued

Turn off and disconnect the power. Reconnect the brown lead to terminal strip terminal G, and replace parts.

If the PC board or transistor must be replaced, proceed as follows:

Table 5-1. Direct Support and General Support Troubleshooting - Continued

MALFUNCTION**TESTING OR INSPECTION****CORRECTIVE ACTION**

4 - Continued

Remove nuts (1, fig. 5-7), lock washers (2), and flat washers (3), and pull off label (4). Remove screws (5 and 6).

If only transistor (13) must be replaced, unsolder wires (15) at the PC board (16). Remove nut (7), washers (8, 9, and 10), and screw (11).

Separate heat sink (12) and insulator (14) from transistor (13). New transistors are supplied with attaching hardware (7 through 11), and insulator (14). Apply heat sink compound (Dow Corning No. 340 or equivalent) to adjacent surfaces of transistor and heat sink. Assemble with insulator (14) between, and secure with attaching hardware. Cut new wires to length, and slide a short length of heat shrink tubing onto each wire. Using a heat sink on the transistor leads, solder the wires to the transistor as shown in figure 5-8, and shrink the tubing over the connections. Use rosin core electrical solder. Solder the wires to the PC board as shown, and spray with moisture repellent conforming to MIL-V-173. Reassemble in the reverse order of removal.

If the PC board and transistor are to be replaced as an assembly, unsolder wires to time delay assembly and control box wiring harness. Install a new assembly by resoldering wires to the same holes in the board. Refer to figure 5-9 for connections. Use only rosin core electrical solder, and spray with a moisture repellent conforming to MIL-V-173. Reassemble in the reverse order of removal.

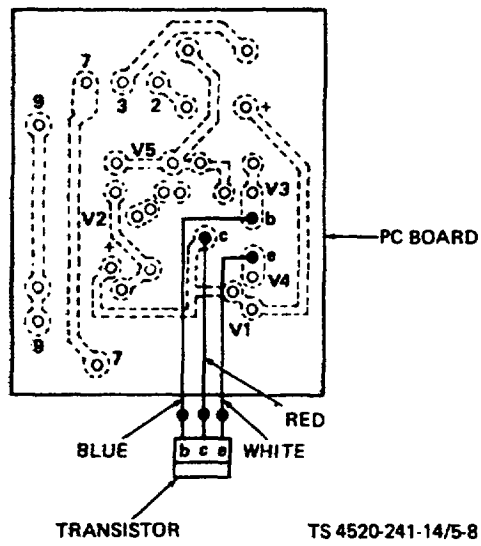

Figure 5-8. Transistor connector.

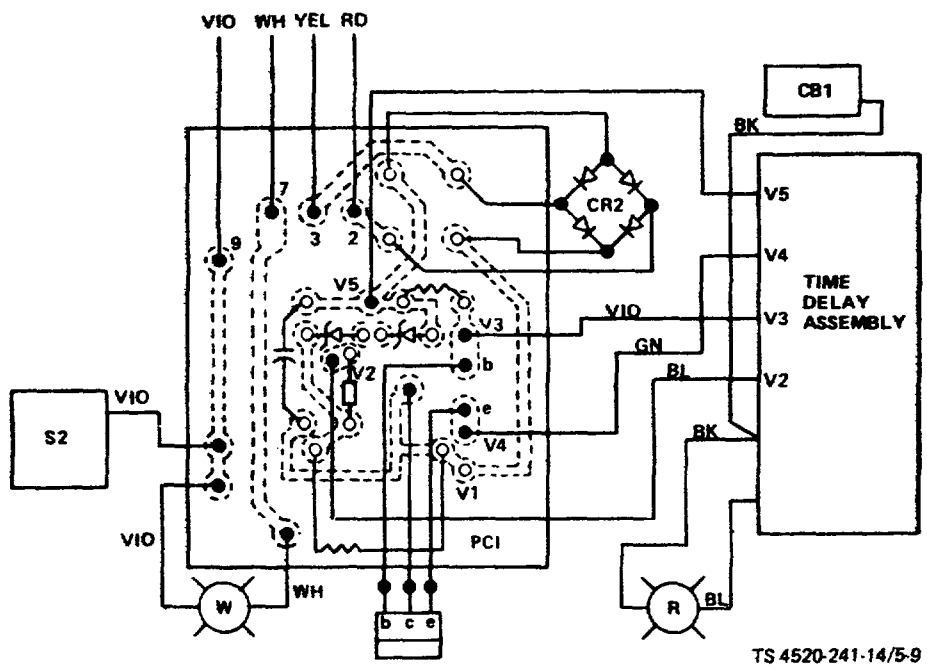

Figure 5-9. Control box wiring.

Table 5-1. Direct Support and General Support Troubleshooting - Continued

MALFUNCTION**TESTING OR INSPECTION****CORRECTIVE ACTION**

4 - Continued

Step 3. Check continuity through bimetallic heater/sensor. Refer to figure 5-9 and check continuity from V4 and V5, and between V2 and V3. There should be resistance across each pair of terminals, but if either is open, replace the bimetallic heater/sensor as an assembly.

Unsolder four wires from heater/sensor to terminal strip in time delay assembly. Remove two screws (1, fig. 5-10) and washers (2), and pull off insulators (3) and heater/sensor (4). Install in the reverse order of removal. Connect the two white wires from inside the heater/sensor to V2 and V3. Connect the two wires from the outer wrap to V4 and V5. Use rosin core electrical solder, and spray with moisture repellent conforming to MIL-V-173.

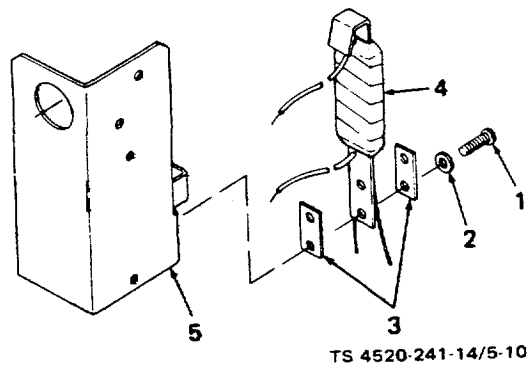

- | | |
|--------------|-----------------------------|
| 1. Screw | 4. Bimetallic heater/sensor |
| 2. Washer | 5. Mounting shelf |
| 3. Insulator | |

Figure 5-10. Bimetallic heater/sensor installation.

SECTION III. GENERAL MAINTENANCE**5-6. ELECTRICAL COMPONENTS.****WARNING**

This space beater contains dangerous voltages which can cause severe electrical shock. Be sure to disconnect the power plug before repairing the heater.

- a. Disconnect the power plug. Open the access doors and remove the side panels.
- b. Clean all electrical components by wiping with a clean, dry cloth.
- c. Inspect all wires for cracks or broken insulation.
- d. Inspect all receptacles and cables for bent or damaged pins and for defective or corroded sockets.
- e. Inspect all wires and electrical components for continuity.
- f. Inspect all terminals for damage or corrosion and replace any defective terminals.
- g. Check all grounding leads and grounding straps.

5-7. MECHANICAL COMPONENTS.**WARNING**

Clean parts in a well-ventilated area. Avoid inhalation of solvent fumes and prolonged exposure of skin to cleaning solvent. Wash exposed skin thoroughly. Dry cleaning solvent (fed. spec. P-D-680) used to clean parts is potentially dangerous to personnel and property. Do not use near open flame or excessive heat. Flash point of solvent is 100°F (38°C).

- a. Clean all mechanical components with a cloth dampened with dry cleaning solvent (fed. spec. P-D-680). Wipe thoroughly and allow to dry.
- b. Inspect all painted surfaces and touch up where necessary.
- c. Inspect all mechanical linkages and hinges for binding or improper operation. Restore to normal working order or replace.

5-8. HARDWARE.

- a. Clean all hardware by immersing in dry cleaning solvent (fed. spec. P-D-680). Wipe thoroughly and allow to dry.
- b. Inspect all threaded parts for broken or damaged threads and replace as needed.
- c. Inspect bright metal hardware for integrity of plating, and replace any corroded parts.

SECTION IV. REMOVAL AND INSTALLATION OF MAJOR COMPONENTS AND ASSEMBLIES

5-9. CONTROL BOX.

a. Removal.

(1) Detach the control box from the heater case by unlocking the two stud turnlock fasteners from inside the control box. Disconnect the male plug of the control box wiring harness from the female receptacle of the heater's electrical harness.

(2) The individual components of the control box can be readily removed at this point.

b. Installation. Install in reverse order of removal.

5-10. HEATER CASE ASSEMBLY.

a. Removal.

(1) The right and left side panels can be removed by unlocking the stud turnlock fasteners which secure them to the heater case.

(2) Remove the hardware that secures the access doors to the heater case; remove the access doors.

(3) The data plates are riveted to the heater case. The rivets must be drilled out and replaced to install new data plates.

b. Installation. Install in reverse order of removal.

5-11. WIRING HARNESS.



This space heater contains dangerous voltages which can cause severe electrical shock. Be sure to disconnect the power plug before repairing the heater.

a. Removal.

(1) Remove the hardware which mounts the power and fuel pump receptacles to the heater case.

(2) Remove all wires from their connection points at the terminal board, flame switch, and other components. Tag the wires to aid in replacement.

b. Installation. Install in reverse order of removal. Consult wiring diagram.

5-12. COMBUSTION MOTOR.

WARNING

This space heater contains dangerous voltages which can cause severe electrical shock. Be sure to disconnect the power plug before repairing the heater.

a. Removal.

(1) Remove the support tube (3, fig. 5-11) by removing screw (1) and lock washers (2). Loosen the hose clamp and pull off the air duct.

(2) Remove the top motor housing assembly (10) from the heater case by removing nuts (4), and washers (5, 6, and 7).

(3) Detach the brown and white leads at their terminal ends.

(4) Remove screws (8) and lock washers (9). Separate top motor housing (10) from bottom motor housing (13). Replace grommet (11) and pads (12) if they are damaged.

(5) Remove bottom motor housing assembly (13).

(6) Pull off sealing tape. Pry off motor housing (19) from motor (20). Remove nut (14), screw (15), lock washer (16), and ground strap (17). Replace pad (18) if it is damaged.

(7) Combustion motor (20) is now ready for inspection and repair. Replace pads (21) if they are damaged. The motor housing should be left attached to the combustion motor by the two black leads.

b. Installation. Install in reverse order of removal. Note the following:

(1) Secure ground strap (17) and the ground strap from the motor to the motor housing (19) with screw (15), washer (16), and nut (14).

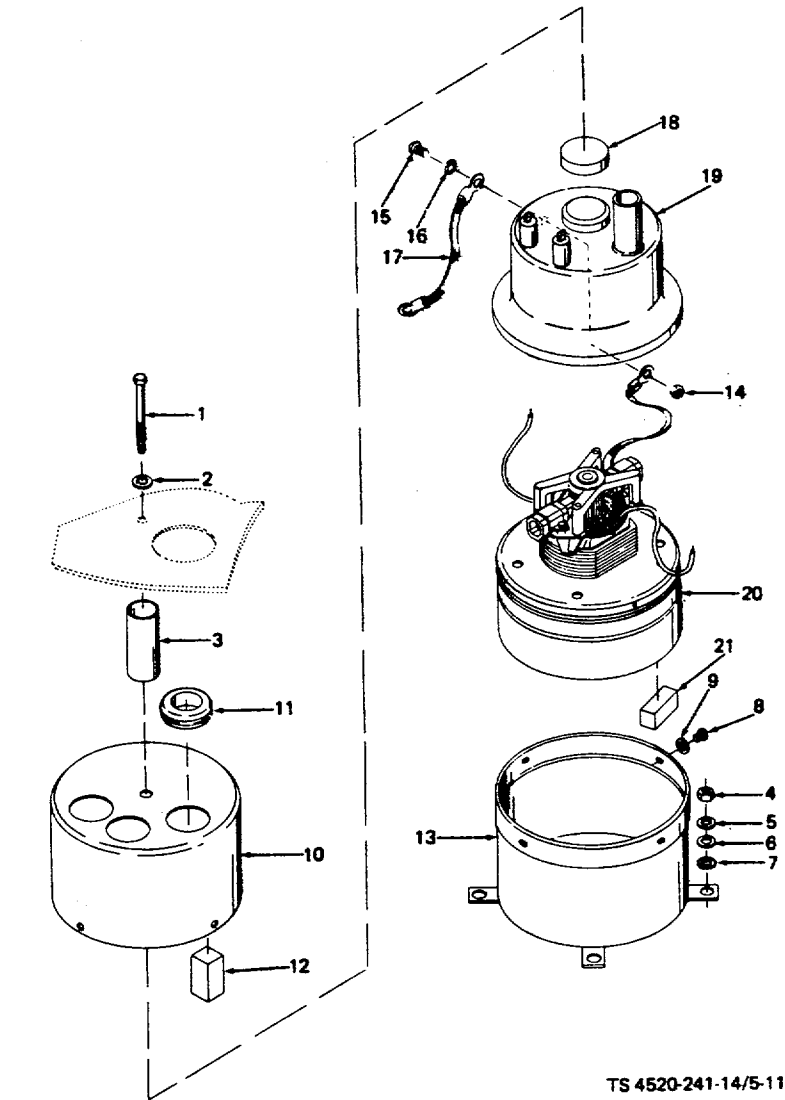

TS 4520-241-14/5-11

- | | |
|--------------------------------|-----------------------------------|
| 1. Screw | 12. Pad |
| 2. Lock washer | 13. Bottom motor housing assembly |
| 3. Support tube | 14. Nut |
| 4. Nut | 15. Screw |
| 5. Lock washer | 16. Lock washer |
| 6. Flat washer | 17. Ground strap |
| 7. Lock washer | 18. Pad |
| 8. Screw | 19. Motor housing |
| 9. Lock washer | 20. Combustion motor |
| 10. Top motor housing assembly | 21. Pad |
| 11. Grommet | |

Figure 5-11. Removal of combustion motor.

- (2) Install motor housing (19) on motor (20) as shown in figure 5-12. Retain the motor housing to the motor by staking the housing with a prick punch at three places around the joint. Seal notches with General Electric RTV-102, or equivalent.
- (3) Seal the housing-to-motor joint with tape before reinstalling in bottom motor housing assembly (13).

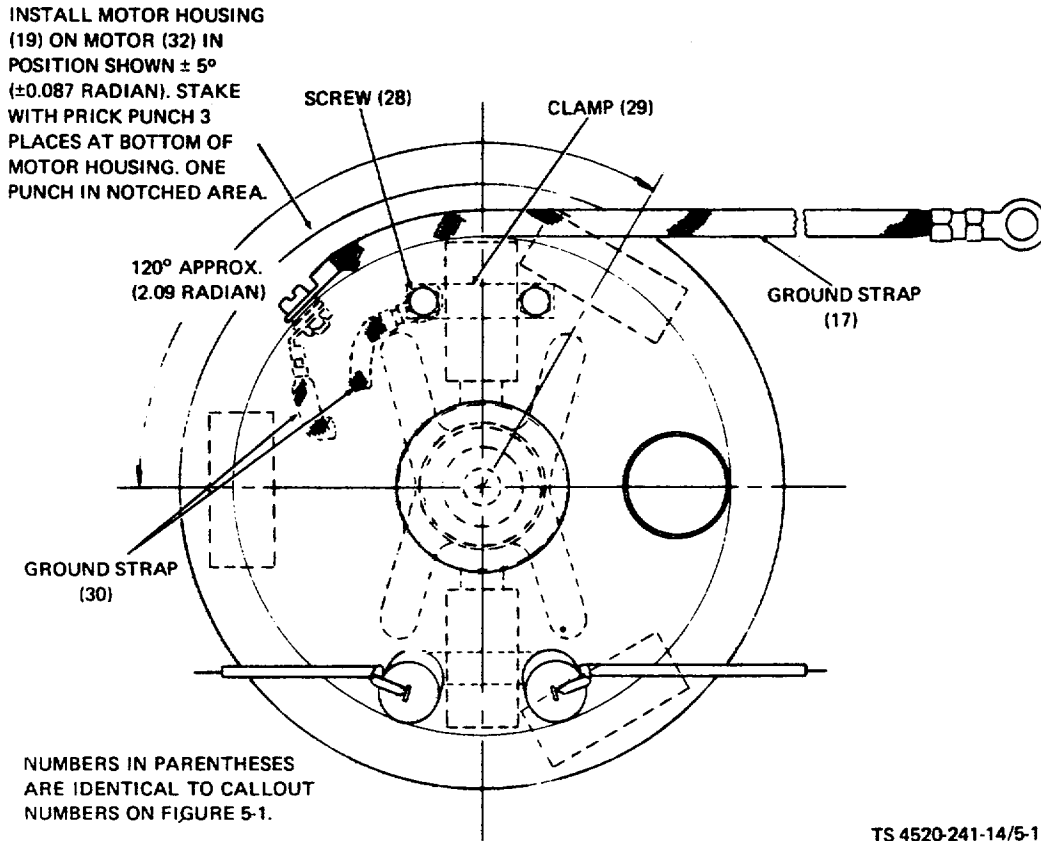

Figure 5-12. Combustion motor assembly relationships.

5-13. VENTILATING MOTOR.

WARNING

This space heater contains dangerous voltages which can cause severe electrical shock. Be sure to disconnect the power plug before repairing the heater.

a. Removal.

- (1) Disconnect the orange and white leads from the ventilating motor at the terminal board and the electrical connector, respectively.

(2) Remove the ventilating motor and its mounting bracket by removing screws (1, fig. 5-13) and lock washers (2).

(3) Remove nut (3), lock washer (4), cable clamp (5), lock washer (6), and screw (7) to unfasten one end of grounding strap (21).

(4) Remove nuts (8), lock washers (9), and screws (10) to separate and remove the two motor mounting brackets (11).

(5) Pull the mounting pads (12) off the motor assembly if they are damaged.

(6) Remove screw (13), lock washer (14), blower disc (15), and spacer (16) so that the fan can be removed.

(7) Loosen both set screws (18) and remove axial fan (17).

(8) Remove the one nut (19) and lock washer (20) which secure the grounding strap (21) to the ventilating motor (22). The ventilating motor is now ready for inspection. No repair is authorized.

b. Installation. Installation of the motor is the reverse of removal. Note the following:

(1) Be sure the axial fan (17) is secure on the motor shaft. Check that both set screws (18) are firmly tightened.

(2) Check installed height of axial fan as shown in figure 5-14. Fan must be positioned as shown to ensure maximum efficiency. Loosen nuts (8) and slide the motor up or down within brackets (11) to obtain this dimension.

(3) Check that openings for knockout plug and wire slot are sealed. If they are not, seal with General Electric RTV-102, or equivalent, before installation.

(4) Route the orange motor wire through the grommet in the heater case shelf and connect to terminal E on the terminal strip. Connect the white wire to the three-way electrical connector near the ignition transformer assembly.

5-14. FUEL PUMP POWER SUPPLY. Remove the two mounting screws which secure the fuel pump power supply to the front of the heater case. Disconnect the gray, white, and yellow leads at their respective terminal connections.

5-15. BURNER ASSEMBLY.

a. Removal.

(1) Disconnect the ignition cable. Remove the igniter (1, fig. 5-15) from the burner head.

(2) Disconnect the fuel lines and wires to the carburetor. Remove four screws (2) which fasten carburetor (3) to the burner head.

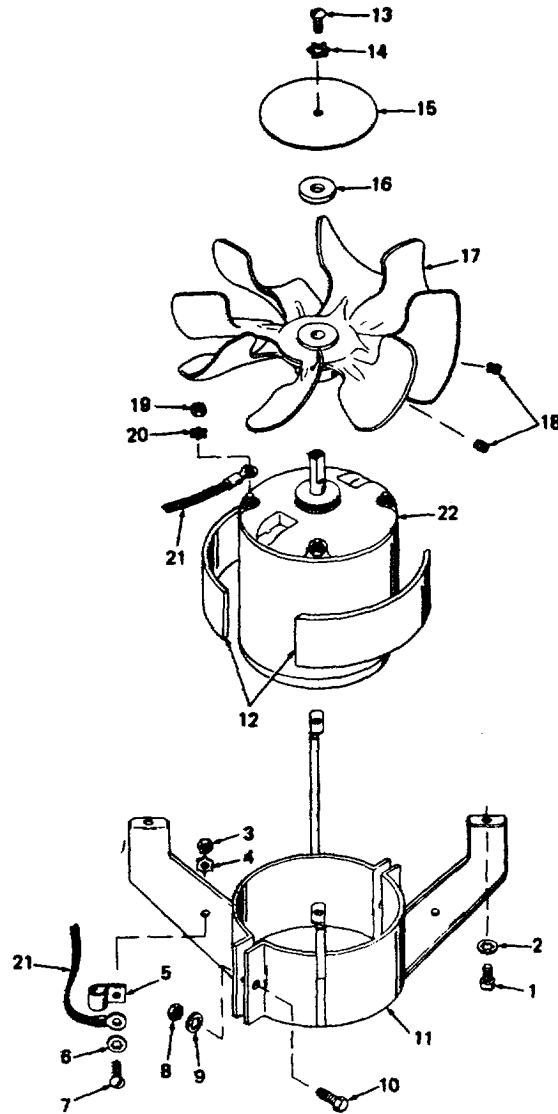

TS 4520-241-14/5-13

- | | |
|----------------------------|-----------------------|
| 1. Screw | 12. Mounting pad |
| 2. Lock washer | 13. Screw |
| 3. Nut | 14. Lock washer |
| 4. Lock washer | 15. Blower disc |
| 5. Cable clamp | 16. Spacer |
| 6. Lock washer | 17. Axial fan |
| 7. Screw | 18. Set screw |
| 8. Nut | 19. Nut |
| 9. Lock washer | 20. Lock washer |
| 10. Screw | 21. Grounding strap |
| 11. Motor mounting bracket | 22. Ventilating motor |

Figure 5-13. Removal of ventilating motor.

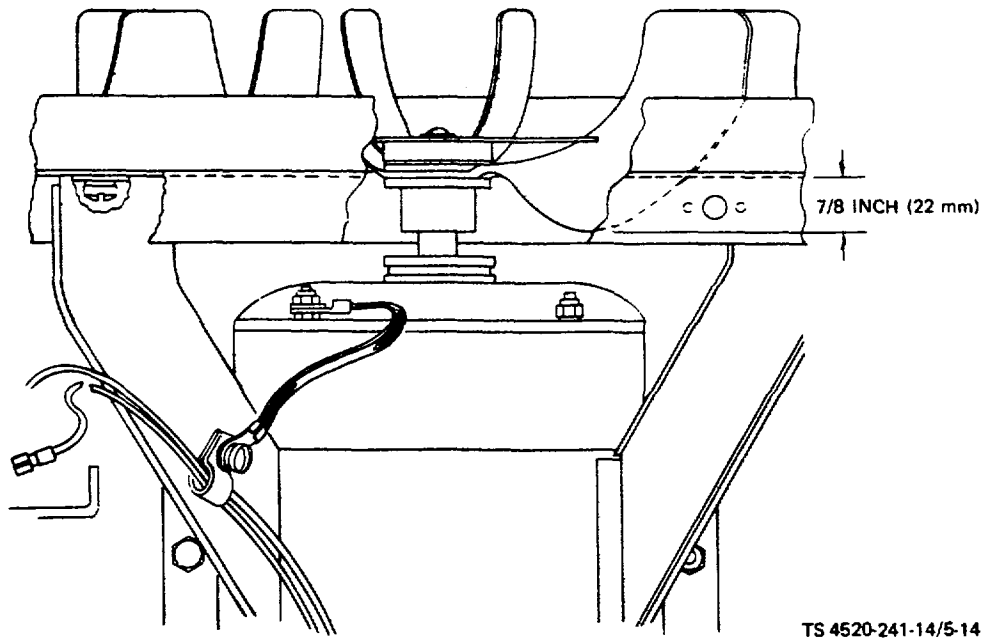

Figure 5-14. Ventilating motor fan dimensions.

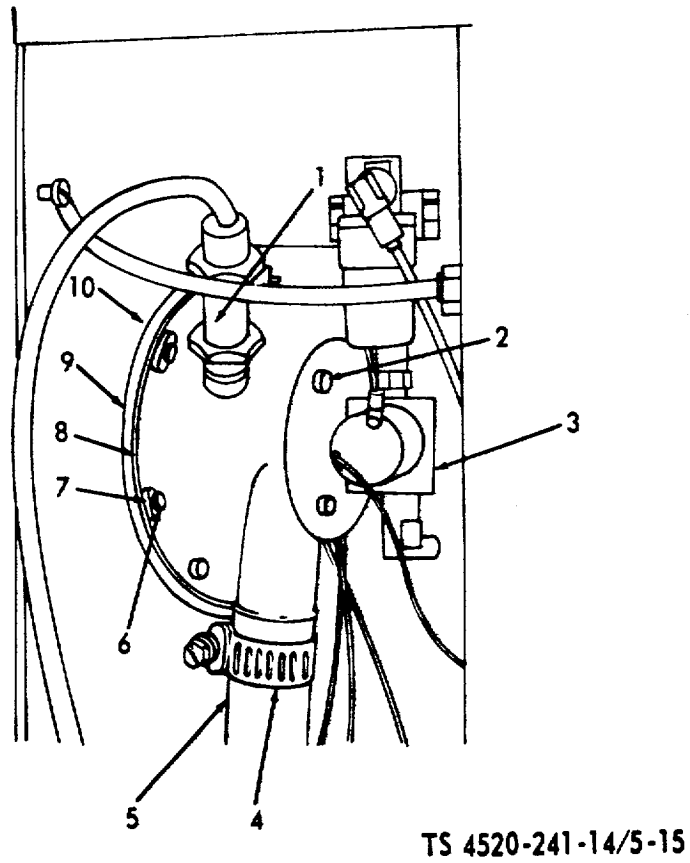

Figure 5-15. Removal of burner assembly.

KEY to fig. 5-15:

- | | |
|---------------|--------------------|
| 1. Igniter | 6. Screw |
| 2. Screw | 7. Pressure pad |
| 3. Carburetor | 8. Gasket |
| 4. Hose clamp | 9. Burner head |
| 5. Air duct | 10. Heat exchanger |

(3) Loosen the hose clamp (4) and pull air duct (5) off the burner head.

(4) Remove five screws (6) and pressure pads (7) which secure the burner head (9) to the heat exchanger (10).

b. Installation. Install burner assembly in reverse order of removal.

5-16. HEAT EXCHANGER.

a. Removal.

(1) Remove the burner assembly from the heat exchanger at the front of the heater case per paragraph 5-15. Pull out insulators (1 and 2, fig. 5-16).

(2) Remove eight screws (3) and lock washers (4) which secure rear cover (11) to the rear of the heater case (14).

(3) Remove four screws (5) and lock washers (6) which secure the heat exchanger to the rear cover (11). Remove the rear cover.

NOTE

It is not necessary to remove screws (7), lock washers (8), support straps (9), and shield (10) to remove the heat exchanger. The shield should be examined for evidence of overheating. Replace if necessary.

(4) Remove asbestos shield (12) and pull out heat exchanger (13).

b. Installation. Install in reverse order of removal and note the following:

(1) Seal heat exchanger where it mates with heater case at front of heater. Use a silicone rubber adhesive sealant such as General Electric RTV 106, RED, or equivalent.

(2) Before installing burner head, install insulators (1 and 2) inside front end of heat exchanger. See figure 5-17.

Insulators are split to facilitate installation. Work four insulators with smaller hole into heat exchanger to rest against inner ring. Work the remaining two insulators (with larger hole) into heat exchanger as shown.

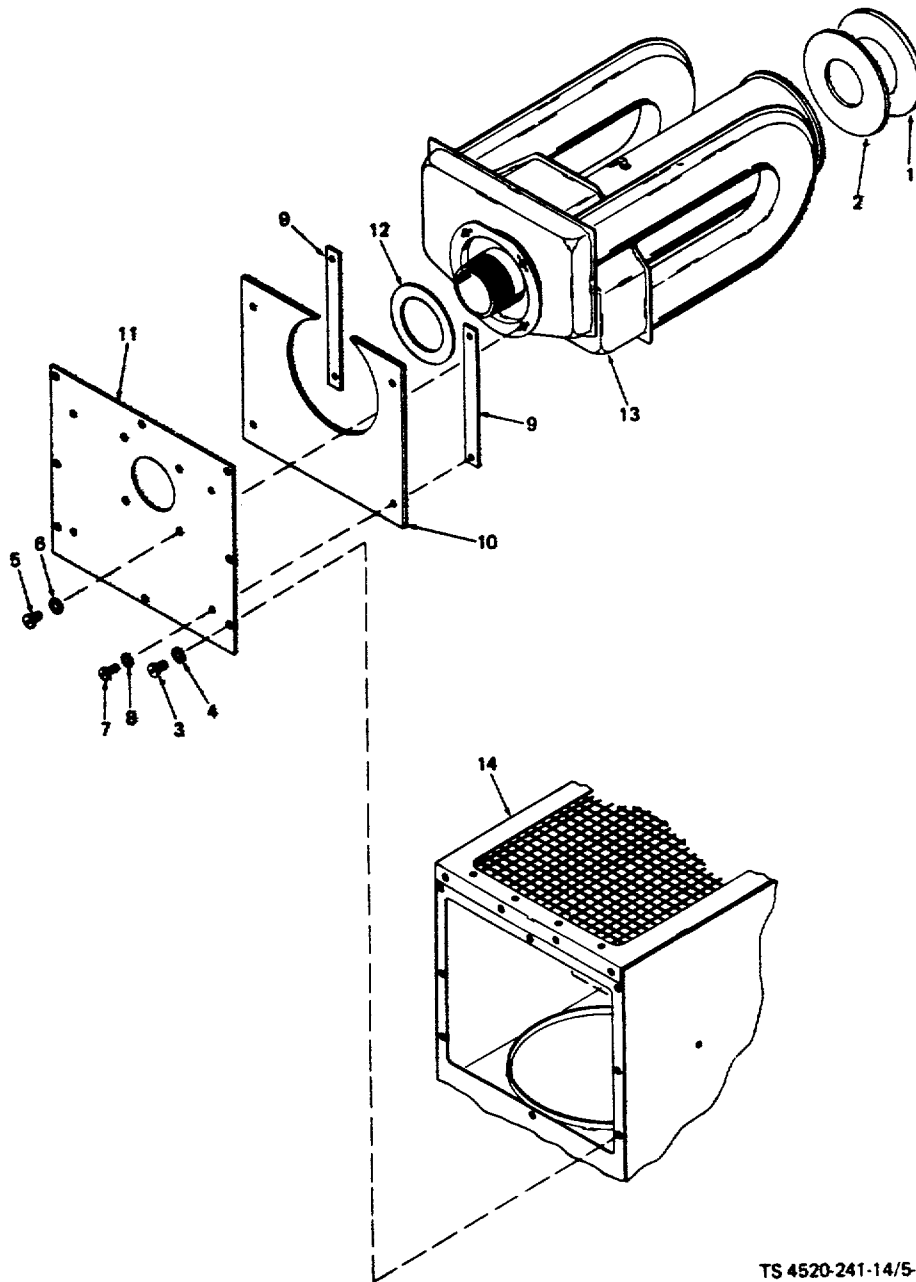

TS 4520-241-14/5-16

- | | |
|----------------|---------------------|
| 1. Insulator | 8. Lock washer |
| 2. Insulator | 9. Support strap |
| 3. Screw | 10. Shield |
| 4. Lock washer | 11. Rear cover |
| 5. Screw | 12. Asbestos shield |
| 6. Lock washer | 13. Heat exchanger |
| 7. Screw | 14. Heater case |

Figure 5-16. Removal of heat exchanger.

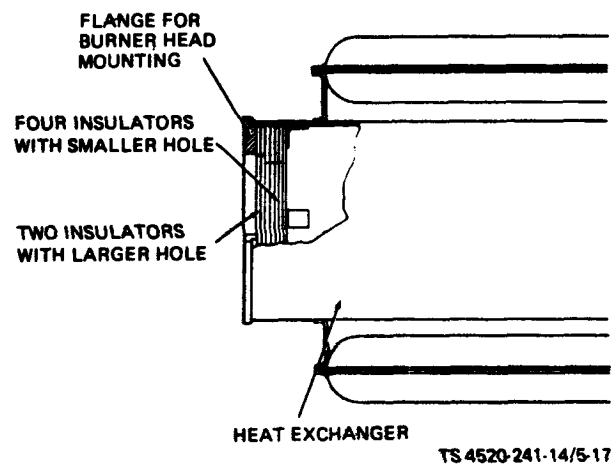

Figure 5-17. Heat exchanger insulator installation.

CHAPTER 6

REPAIR OF CONTROL BOX ASSEMBLY

6-1. DESCRIPTION.

The control box houses the following components which control heater operation. Only the wiring harness and time delay assembly require maintenance at the direct support level.

a. Room Thermostat Receptacle. The room thermostat receptacle is a military standard three-wire receptacle for connecting the cable to the room thermostat into the heater control circuits.

b. HEATER-OFF-FAN Switch. The HEATER-OFF-FAN switch maintains the heater in the HEATER or FAN mode, or deenergizes all components except the circuit breaker.

c. Wiring Harness. The wiring harness connects the electrical circuits inside the heater case to the control components in the control box.

d. PC Board and Transistor. The PC board and transistor are the electrical components which convert the time delay transformer output to DC and then energize the components in the time delay assembly.

e. Time Delay Assembly. The time delay assembly provides a time delay sufficient for the heater to establish proper combustion. A thermistor in the bimetallic/sensor compensates for the wide range of voltages which may be encountered over the entire range of starting temperatures. When the flame switch senses proper combustion temperatures in the heat exchanger, it throws to normal operation and deenergizes the time delay assembly.

6-2. CONTROL BOX WIRING HARNESS.

WARNING

This space heater contains dangerous voltages which can cause severe electrical shock. Be sure to disconnect the power plug before repairing the heater.

a. Disassembly.

(1) Remove the room thermostat receptacle (1, fig. 6-1) from the control box by removing four screws, lock washers, and nuts.

(2) Remove the two green leads (2) from the grounding screw. Remove clamp (3) by removing the center screw on the control box hinge.

(3) Remove the black lead (4) from the circuit breaker. Pull out male plug (5).

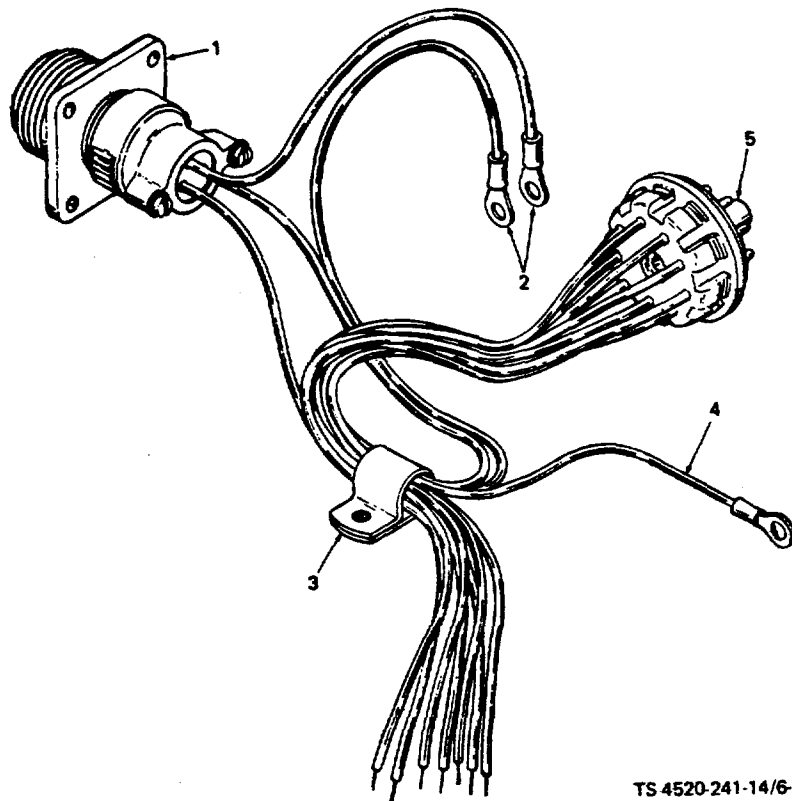

TS 4520-241-14/6-1

- | | |
|-------------------------------|---------------|
| 1. Room thermostat receptacle | 4. Black lead |
| 2. Green leads | 5. Male plug |
| 3. Clamp | |

Figure 6-1. Control box wiring harness.

(4) Remove the red, yellow, white, blue, orange, and two violet wires from the PC board by scraping away the insulating material and unsoldering. Pull the harness and room thermostat receptacle out of the control box.

(5) Unsolder the black/white, green, and violet wires from the room thermostat receptacle.

(6) Unsolder the nine wires from the male plug by applying a soldering iron to the tip of the pins and pulling gently on the wires until they can be removed easily.

b. Cleaning and Inspection.**WARNING**

Clean parts in a well-ventilated area. Avoid inhalation of solvent fumes and prolonged exposure of skin to cleaning solvent. Wash exposed skin thoroughly. Dry cleaning solvent (fed. spec. P-D-680) used to clean parts is potentially dangerous to personnel and property. Do not use near open flame or excessive heat. Flash point of solvent is 100°F (38°C).

(1) Clean all electrical parts with a cloth dampened with dry cleaning solvent (fed. spec. P-D-680).

(2) Inspect the harness for loose or broken terminals, frayed or damaged insulation, or burned wires. Replace any defective parts or replace the complete harness if damage is evident in several components.

c. Reassembly. Reassemble in reverse order of disassembly, using figures 6-1 and 6-2 as guides. Note the following:

(1) Solder all wires with rosin core electrical solder. When soldering wires to the male plug, hold the soldering tool against the pin, insert the wire from the back, and apply solder to the center hole in the pin.

(2) Spray all soldered connections on the PC board with moisture repellent conforming to MIL-V-173 (Columbia Technical Corporation Humi-Seal No. 1A27, Class A, or equivalent).

(3) Reconnect the power plug and test for normal operation.

6-3. PC BOARD AND TIME DELAY ASSEMBLY.

The PC board and transistor assembly and the time delay assembly are closely interconnected with soldered wires, so that removal or disassembly of one may require removal and/or partial disassembly of the other.

WARNING

This space heater contains dangerous voltages which can cause severe electrical shock. Be sure to disconnect the power plug before repairing the heater.

a. Testing. To facilitate testing, perform the following tests before removing the control box from the heater, or otherwise disassembling the heater or case.

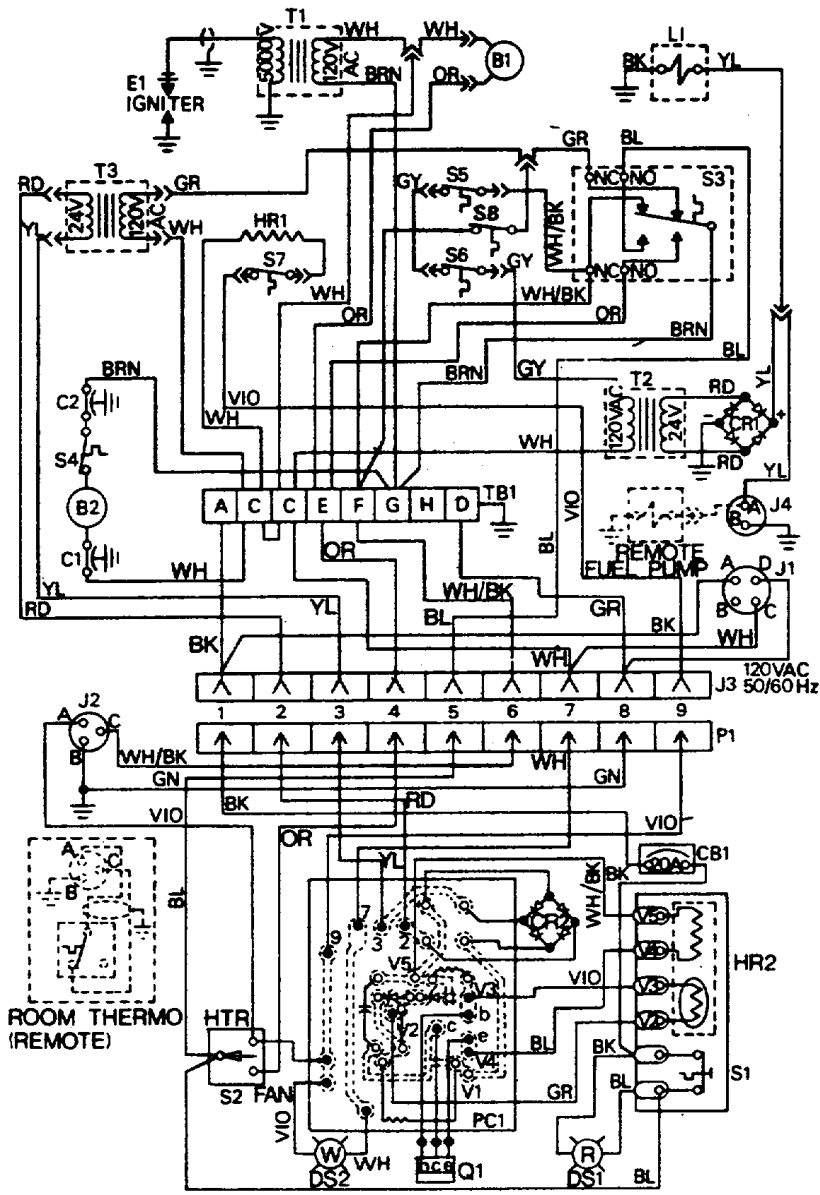

KEY TO DIAGRAM	
B1	Ventilating motor
B2	Combustion motor
C1	Capacitor, interference suppression
C2	Capacitor, interference suppression
CB1	Circuit breaker, 20 amp
CR1	Rectifier (Fuel pump power supply)
CR2	Rectifier (Time delay)
DS1	Incandescent lamp (Red)
DS2	Incandescent lamp (White)
E1	Igniter
HR1	Fuel heater
HR2	Bimetal heater/sensor (Time delay)
J1	POWER RECEPTACLE
J2	ROOM THERMO receptacle
J3	Female receptacle
J4	EXTERNAL FUEL PUMP RECEPTACLE
L1	Solenoid
PC1	PC bad assembly
P1	Male plug (Control box)
Q1	Transistor
S1	Switch, SPST (RESET)
S2	Toggle switch (HEATER-OFF-FAN)
S3	Flame switch
S4	Thermal cutout switch
S5	Overheat thermostat switch
S6	Overheat thermostat switch
S7	Fuel thermostat switch
S8	Safety switch
TB1	Terminal board (Terminal strip)
T1	Ignition transformer
T2	Fuel pump power supply transformer
T3	Time delay transformer

TS 4520-241-14/6-2

Figure 6-2. Wiring diagram.

- (1) Disconnect power plug. Remove the control box and disconnect male plug. Install a jumper from pin 1 to pin 6 in the female receptacle in the heater case.
- (2) Open access doors and disconnect the brown lead to the flame switch at terminal strip terminal G. Connect the power plug and measure voltage at pins 2 and 3 of the female receptacle. Voltage should be 23 to 30 VAC. If it is not, replace the time delay transformer and retest.
- (3) Remove the jumper installed in the female receptacle in step (1). Plug the control box into the female receptacle and reinstall the control box on the front of the heater case. Set the room thermostat above ambient temperature to ensure that its contacts are closed.

- (4) Open the control box cover. Remove nuts (1, fig. 6-3), lock washers (2), and flat washers (3) securing label (4) to the PC board (16). Pull off the label for access to connection points on the board.
- (5) Connect the power plug.



Set up tests and make all test connections before switching the HEATER-OFF-FAN switch to HEATER. All test readings must be made with only momentary actuation of the switch to the HEATER position.

(6) Connect a DC voltmeter to V5 (negative) and to the center pin of the transistor (positive). It may be necessary to scrape away the varnish coating to ensure good contact. (Refer to Appendix D, Expendable Supplies and Materials List.) Momentarily move the switch to HEATER. The voltmeter must read approximately 30 volts. If it reads less than 28 volts, replace the PC board and transistor as an assembly (see below).

(7) Connect the voltmeter to V5 (negative) and V4 (positive). Momentarily move the switch to HEATER. The voltage should be 13 volts. If it is less than 12 volts, replace the transistor. If it is more than 14 volts, replace the PC board and transistor as an assembly.

(8) Connect the voltmeter to V5 (negative) and to V2 (positive). Momentarily move the switch to HEATER. The meter should read approximately 18 volts. If it does not, replace the PC board and transistor as an assembly.

(9) If the PC board and transistor passed the tests in steps (3) through (8), neither part should be removed from the control box control unless required for replacement of other parts.

(10) Check continuity through the bimetallic heater/sensor (33, fig. 6-3) to decide if it must be replaced. Refer to figure 6-5 and check continuity between V4 and V5, and between V2 and V3. There should be resistance across each pair of terminals, but if either is open, replace the bimetallic heater/sensor as an assembly.

(11) Check continuity through the reset switch (25, fig. 6-3). A white plastic knob extends through the switch. When the knob is up (toward the bimetallic heater/sensor) there should be continuity across the switch terminals. Use a pencil or small screwdriver blade to push down the white knob, simulating time delay shutdown. There must be no continuity across the switch terminals. Replace the switch if it does not operate in this manner.

b. Removal and Disassembly.

(1) Remove the control box from the heater by releasing the two stud turnlock fasteners. Disconnect the male plug.

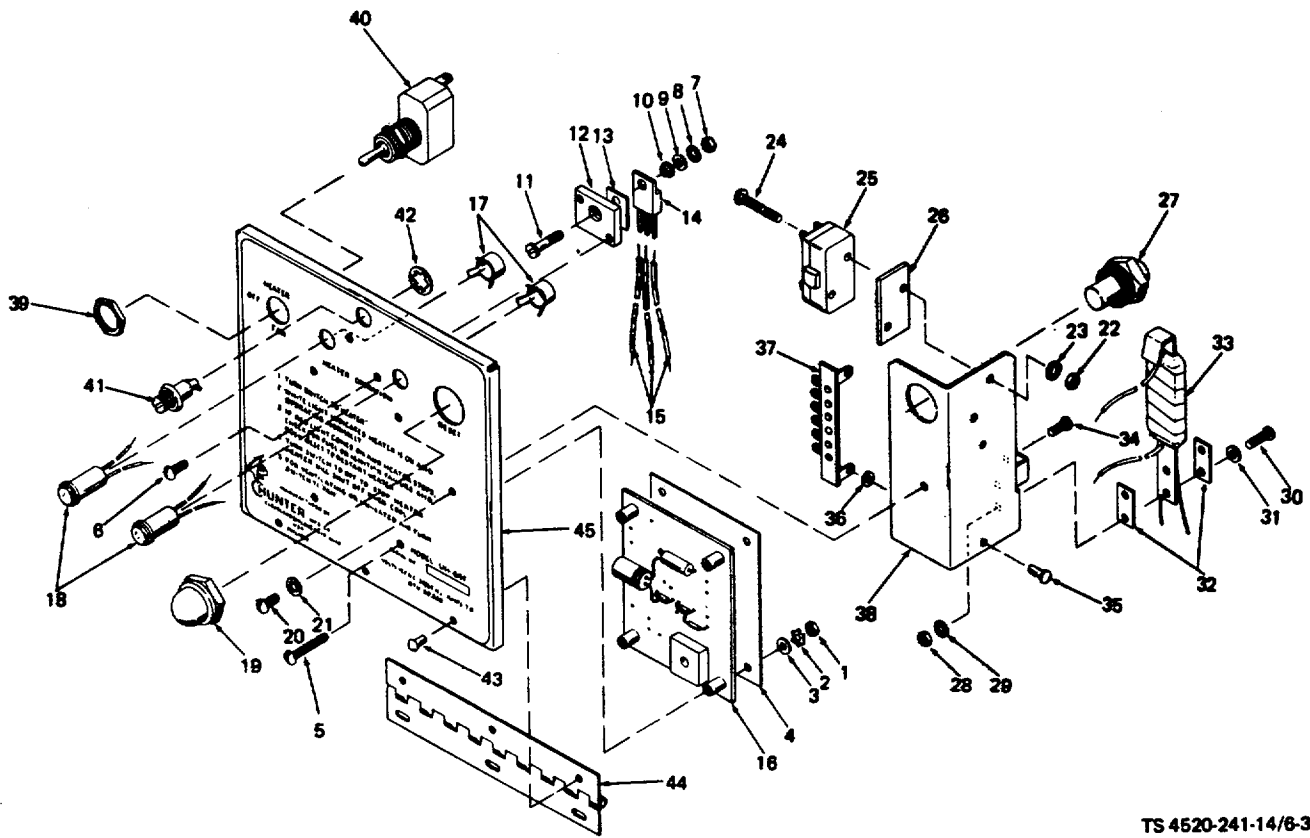

TS 4520-241-14/6-3

- | | |
|---------------------|------------------------------|
| 1. Nut | 24. Screw |
| 2. Lock washer | 25. Reset switch |
| 3. Flat washer | 26. Spacer |
| 4. Label | 27. Reset button |
| 5. Screw | 28. Nut |
| 6. Screw | 29. Lock washer |
| 7. Nut | 30. Screw |
| 8. Lock washer | 31. Flat washer |
| 9. Washer | 32. Spacer |
| 10. Shoulder washer | 33. Bimetallic heater/sensor |
| 11. Screw | 34. Screw |
| 12. Heat sink | 35. Rivet |
| 13. Insulator | 36. Flat washer |
| 14. Transistor | 37. Terminal strip |
| 15. Wires | 38. Mounting shelf |
| 16. PC board | 39. Nut |
| 17. Barrel fastener | 40. HEATER-OFF-FAN switch |
| 18. Indicator light | 41. Stud turnlock fastener |
| 19. Boot | 42. Lock washer |
| 20. Screw | 43. Rivet |
| 21. Lock washer | 44. Hinge |
| 22. Nut | 45. Cover |
| 23. Lock washer | |

Figure 6-3. Control box cover assembly.

(2) Remove the four nuts (1, fig. 6-3), and washers (2 and 3). Pull off label (4).

(3) Remove screws (5 and 6). If the PC board and transistor assembly are being loosened to permit removal of other components, no further disassembly is recommended.

(4) If the PC board and transistor are being replaced as an assembly, scrape away the coating over the solder connections on the foil side of the PC board, and unsolder the wires.

NOTE

Items 7 through 15 are also available as a complete assembly. It is recommended that these parts be replaced as an assembly, rather than replacing the transistor separately.

(5) If only the transistor is being replaced, scrape away the coating over the solder connections on the PC board and unsolder the wires (15) to the transistor. Remove nut (7), washers (8, 9, and 10), and screw (11) securing heat sink (12) to transistor (14). Separate the heat sink and insulator (13) from the transistor.

(6) Wires on the white indicator light (18) are soldered to the PC board. Wires on the red indicator light (18) are soldered to the time delay assembly terminal strip (37). If the lights must be replaced, unsolder the wires and remove barrel fasteners (17) which secure the lights to the cover (45).

(7) If the time delay assembly must be replaced, unsolder the remaining wires to it. Remove boot (19), screw (20), and lock washer (21). Pull off the time delay assembly.

(8) Unsolder the wires to reset switch (25). Remove nuts (22), lock washers (23), and screws (24) which secure the reset switch to mounting shelf (38). Pull off the switch and spacer (26). RESET button (27) can also be removed.

NOTE

The bimetallic heater/sensor can be removed without removal of the reset switch.

(9) Remove nuts (28), lock washers (29), screws (30), and washers (31) securing bimetallic heater/sensor (33) to the mounting shelf. Pull off the sensor and spacers (32).

(10) If terminal strip (37) must be replaced, unsolder remaining wires and drill out rivets (35).

(11) HEATER-OFF-FAN switch (40) is shown for reference. If it must be removed, unsolder wires and remove nut (39).

(12) If stud turnlock fastener (41) is worn, loose, or damaged, pry off lock washer (42) and remove the stud turnlock fastener.

(13) If hinge (44) is damaged, drill out rivets (43) to remove hinge from cover (45).

c. Cleaning and Inspection.

WARNING

Clean parts in a well-ventilated area. Avoid inhalation of solvent fumes and prolonged exposure of skin to cleaning solvent. Wash exposed skin thoroughly. Dry cleaning solvent (fed. spec. P-D-680) used to clean parts is potentially dangerous to personnel and property. Do not use near open flame or excessive heat. Flash point of solvent is 100°F (38°C).

(1) Clean all electrical parts with a cloth dampened with dry cleaning solvent (fed. spec. P-D-680), and dry thoroughly.

(2) Clean all other parts with cleaning solvent and dry thoroughly.

(3) Tests for functioning parts of the time delay were described in paragraph a. No functional tests of the PC board are available for bench testing.

(4) Inspect all wires for cracked, burned, or abraded insulation. Replace defective wires.

(5) Inspect all hardware parts for stripped or damaged threads or other damage. Replace defective parts.

(6) The operating instructions embossed on the cover cannot be repaired. Replace the cover if the markings on it are illegible. Be sure to transfer the heater serial number to the new cover.

d. Reassembly. Reassembly of the control box is essentially the reverse of disassembly. Note the following:

NOTE

Items 7 through 15 are also available as a complete assembly. It is recommended that these parts be replaced as an assembly, rather than replacing the transistor separately. If this is done, skip steps (1) and (2).

(1) If only the transistor has been replaced, connect the transistor to the PC board as follows. New transistors are supplied with attaching hardware (7 through 11, and 13, fig. 6-3), plus insulator (13). Apply heat sink compound (Dow

Corning No. 340, or equivalent) to adjacent surfaces of transistor and heat sink. Assemble them with the insulator (13) in between, and secure with attaching hardware.

(2) Cut new wires to length and slide a short length of heat shrink tubing onto each wire. Using a heat sink on the transistor leads, solder the wires to the transistor as shown in figure 6-4, and shrink the tubing over the connections with heat from a soldering iron. Use rosin core electrical solder.

(3) Solder the transistor wires to the PC board as shown, and spray the connections with moisture repellent conforming to MIL-V-173 (Columbia Technical Corporation, Humi-Seal No. 1A27, Class A, or equivalent).

(4) Preassemble the time delay assembly before installing the PC board and transistor. Install reset switch (25) and bimetallic heater/sensor (33), and solder the wires to terminal strip (37) as shown in figure 6-5. Use rosin core electrical solder.

(5) If the PC board and transistor have been replaced as an assembly, install a new assembly by resoldering wires to the same holes in the board. Refer to figure 6-5 for connections. Use only rosin core electrical solder.

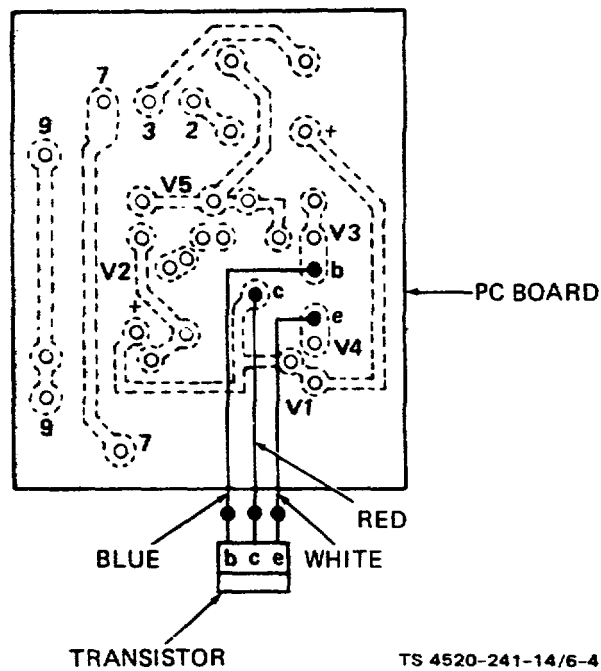

Figure 6-4. Transistor connections.

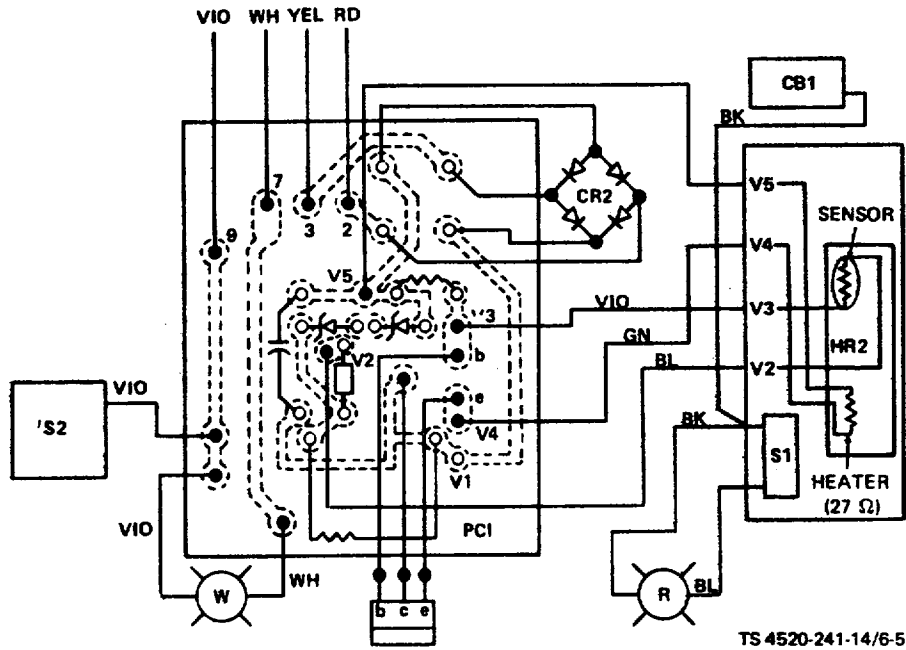

Figure 6-5. Control box wiring.

(6) Reassemble the remaining parts of the control box cover. Before installing label (4, fig. 6-3) over the PC board foil side, spray all connections on the PC board and time delay terminal strip with moisture repellent conforming to MIL-V-173 (Columbia Technical Corporation, Humi-Seal No. 1A27, Class A, or equivalent).

(7) If the bimetallic sensor/heater has been replaced, check the time delay adjustment after installation.

e. Time Delay Adjustment. Adjustment of the time delay is not a normal maintenance adjustment, but may be required after replacement of the bimetallic heater/sensor. Adjust as follows:

(1) Connect the control box male plug to the female receptacle on the heater case. Attach the control box by engaging the two stud turnlock fasteners in the control box.

(2) Leave open the control box cover. Disconnect the yellow lead from the output of the fuel pump power supply transformer so that no power is applied to the carburetor solenoid valve or to the external fuel pump. Disconnect the brown lead at terminal strip terminal G to disconnect the ignition transformer.

(3) Connect the power plug. Press the RESET button to clear the switch. Using a stopwatch or a clock with a sweep second band, move the HEATER-OFF-FAN switch to HEATER and start timing.

(4) The bimetallic heater/sensor must trip the RESET switch within 60 to-90 seconds at an ambient temperature between 65° and 75°F (18° to 24°C). If the time delay operates within this range, no adjustment is required.

(5) If the time delay is outside the specified range, adjust the bimetallic heater/sensor by turning the slotted head screw that moves the end of the sensor closer to or farther from the reset switch. If the time delay was too short, allow the parts to cool for 5 minutes, then turn the screw counterclockwise 1/4 turn. Retest per steps (3) and (4). If the time was too long, allow the parts to cool for 5 minutes, then turn the screw clockwise 1/4 turn. Retest.

(6) When the adjustment is correct, turn off the power and disconnect the power plug. Reconnect the brown lead to terminal G, and the yellow lead to the electrical connector. Close the control box cover. Check the heater for proper operation.

CHAPTER 7

REPAIR OF HEATER CASE ASSEMBLY

7-1. DESCRIPTION.

The heater case consists of a welded steel framework with a shelf and bulkhead which together form four compartments. It also supports side panels, louver linkage, access doors, and a bottom cover. Only the framework requires repair at the direct support level.

7-2. REPAIR.

- a. Straighten any bends and hammer out any dents which interfere with the mounting or operation of heater components. Replace any missing hardware. (See figure 7-1).
- b. Drill out rivets (18) to replace any of the receptacles (19) which are used to secure panels.
- c. Make sure grounding strap (9) is fastened securely to one of the mounting brackets.
- d. Mount handle plates (4) with widest dimension toward top of heater to protect hands when carrying heater.
- e. If bulkhead (14) must be removed, remove the ignition transformer leads, the ignition transformer, and the pivot bar for the louver linkage before removing bulkhead.

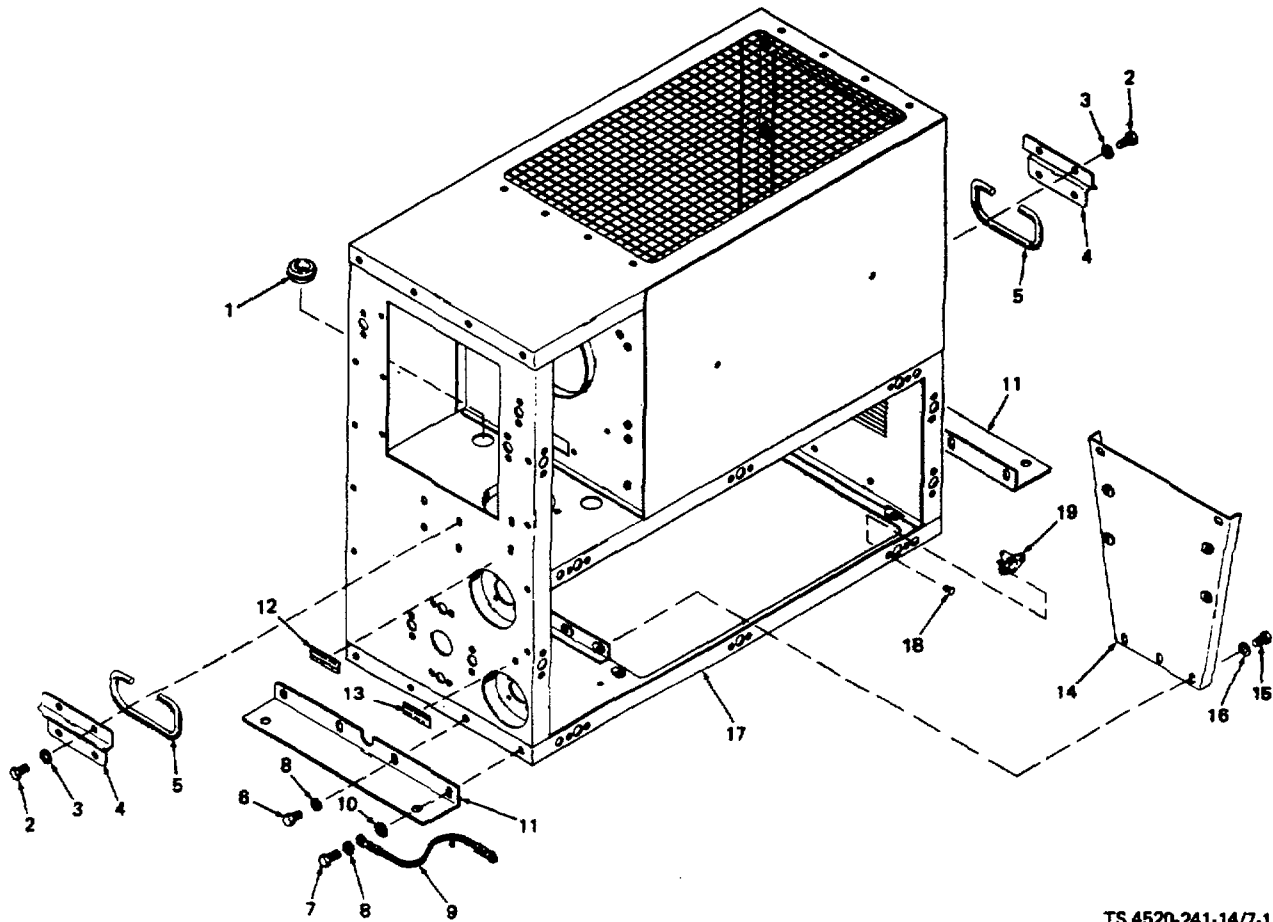

TS 4520-241-14/7-1

- | | |
|--------------------|----------------------------------|
| 1. Grommet | 11. Mounting bracket |
| 2. Screw | 12. Label, fuel receptacle |
| 3. Lock washer | 13. Label, power receptacle |
| 4. Handle plate | 14. Bulkhead |
| 5. Handle | 15. Screw |
| 6. Screw | 16. Lock washer |
| 7. Screw | 17. Heater case |
| 8. Lock washer | 18. Rivet |
| 9. Grounding strap | 19. Turnlock fastener receptacle |
| 10. Lock washer | |

Figure 7-1. Heater case assembly.

CHAPTER 8

REPAIR OF ELECTRICAL COMPONENTS

8-1. DESCRIPTION.

- a. Wiring Harness. The wiring harness connects the heater's operating circuits to the control circuits at the mating control box wiring harness. It also contains the power receptacle with built-in radio interference suppressor and the fuel pump power receptacle.
- b. Combustion Motor. The combustion motor supplies air to the burner head to provide efficient combustion.
- c. Ventilating Motor. The ventilating motor blows air across the heat exchanger to supply warm ventilating air to the enclosure. It may also operate as a cooling fan when the heater is in the FAN mode.
- d. Fuel Pump Power Supply. The fuel pump power supply rectifies 120 VAC Line current to 24 VDC to operate the solenoid valve on the carburetor and the remote fuel pump.

8-2. WIRING HARNESS.

- a. Disassembly.

WARNING

This space heater contains dangerous voltages which can cause severe electrical shock. Be sure to disconnect the power plug before repairing the heater.

- (1) Remove hardware (2, 3, and 4, fig. 8-1) to remove the female receptacle (1).
- (2) Remove hardware (5, 6, and 7) to remove filter and receptacle assembly (8).
- (3) Remove hardware (9, 10, 11, and 12) to remove fuel pump receptacle (13).
- (4) Remove the threaded back on the fuel pump receptacle and unsolder the green lead (14) and yellow lead (15). The bullet terminal on the yellow lead can be pulled out of the three-way electrical connector.
- (5) Unsolder the black lead (16), green lead (17), and white lead (18) from the power receptacle. Do not remove these leads from the female receptacle.

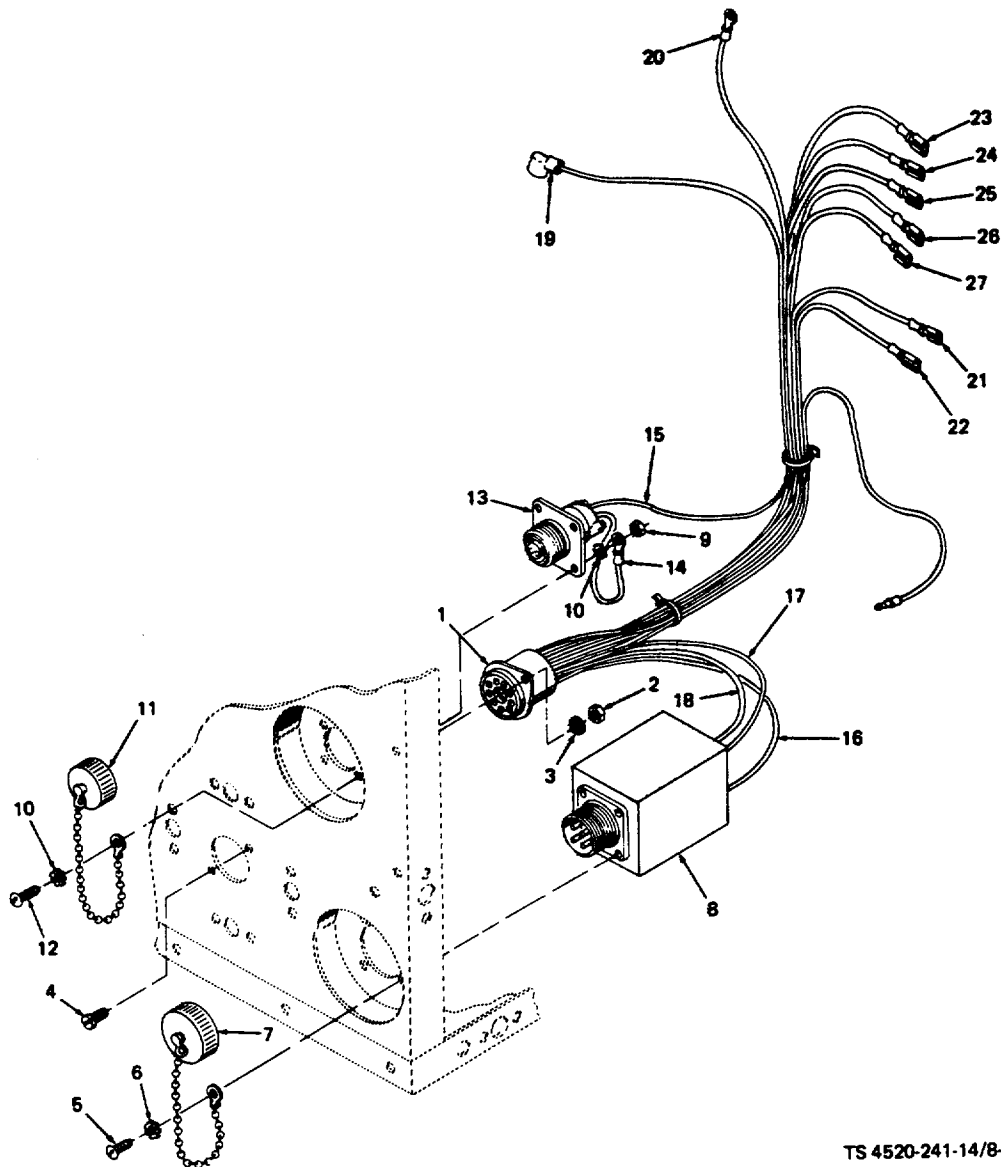

TS 4520-241-14/8-1

- | | |
|-----------------------------------|----------------------|
| 1. Female receptacle | 14. Green lead |
| 2. Nut | 15. Yellow lead |
| 3. Lock washer | 16. Black lead |
| 4. Screw | 17. Green lead |
| 5. Screw | 18. White lead |
| 6. Lock washer | 19. Violet lead |
| 7. Dust cap and chain | 20. Blue lead |
| 8. Filter and receptacle assembly | 21. Yellow lead |
| 9. Nut | 22. Red lead |
| 10. Lock washer | 23. Green lead |
| 11. Dust cap and chain | 24. Black lead |
| 12. Screw | 25. White lead |
| 13. Fuel pump receptacle | 26. Black/white lead |
| | 27. Orange lead |

Figure 8-1. Wiring harness.

- (6) Pull the violet lead (19) with insulated terminal off the fuel beater at the base of the carburetor.
- (7) Remove the blue lead (20) by unscrewing the flame switch terminal screw which secures the lead's ring terminal.
- (8) Remove the yellow lead (21) and red lead (22) from the time delay transformer.
- (9) Remove the green lead (23), black lead (24), white lead (25), black/white lead (26), and orange lead (27) by pulling their terminals off the terminal strip.

NOTE

Do not remove any leads from the female receptacle. It is potted for permanently sealed electrical connections.

b. Cleaning and Inspection.

WARNING

Clean parts in a well-ventilated area. Avoid inhalation of solvent fumes and prolonged exposure of skin to cleaning solvent. Wash exposed skin thoroughly. Dry cleaning solvent (fed. spec. P-D-680) used to clean parts is potentially dangerous to personnel and property. Do not use near open flame or excessive heat. Flash point of solvent is 100° F (38°C).

- (1) Clean all electrical parts with a cloth dampened with dry cleaning solvent (fed. spec. P-D-680).
- (2) Clean all non-electrical parts by immersing them in an approved cleaning solvent. Dry thoroughly.
- (3) Inspect all wires for cracked, burned, or abraded insulation. Replace individual wires as needed, except that wires connected to the female receptacle cannot be replaced. If any wire potted to the receptacle is defective, replace with wiring harness as an assembly.
- (4) Check all receptacles for electrical connections. Check continuity across all receptacle pins.
- (5) Check for broken or damaged terminals on the leads. Replace any defective terminals.
- (6) Test continuity through the filter and receptacle assembly. This unit is not repairable; replace the assembly if it is open or damaged.

c. Assembly. Assembly of the wiring harness is the reverse of disassembly. Use rosin core electrical solder for all soldered connections. Spray all soldered joints with a moisture repellent conforming to MIL-V-173 (Columbia Technical Corporation Humi-Seal, No. 1A27, Class A, or equivalent).

8-3. COMBUSTION MOTOR.

a. Disassembly.

(1) Unsolder wires (5 and 6, figure 8-2) from suppression capacitors (3), and pull off motor housing (4). Remove nuts (1) and washers (2) to remove capacitors from motor housing.

(2) If thermal cutout (9) must be replaced, cut and discard Ty-rap (7), and cut off butt connectors (8) to remove them from wires (5 and 10).

(3) Remove brush holding screws (11) and brush holder clamps (12) that secure carbon brush assemblies (13). Ground strap (14) is secured under one screw (11).

(4) Lift the carbon brush assemblies to one side and remove field screws (15).

(5) Remove frame cap (16) and pry out loading spring (17).

(6) Remove nut (18) and washer (19). Pull out armature (20) and field (21).

(7) Remove upper ball bearing (22) from the armature shaft only if replacement is necessary.

(8) Pry off housing frame assembly (23). Remove lower bearing (22) only if it must be replaced. Lift out spacer (24), fan assemblies (35), spacer spool (26), upper chamber (27), and lower chamber (28).

b. Cleaning and Inspection.

WARNING

Clean parts in a well-ventilated area. Avoid inhalation of solvent fumes and prolonged exposure of skin to cleaning solvent. Wash exposed skin thoroughly. Dry cleaning solvent (fed. spec. P-D-680) used to clean parts is potentially dangerous to personnel and property. Do not use near open flame or excessive heat. Flash point of solvent is 100°F (38°C).

(1) Wipe all electrical parts with a cloth dampened in dry cleaning solvent (fed. spec. P-D-680), and allow to dry.

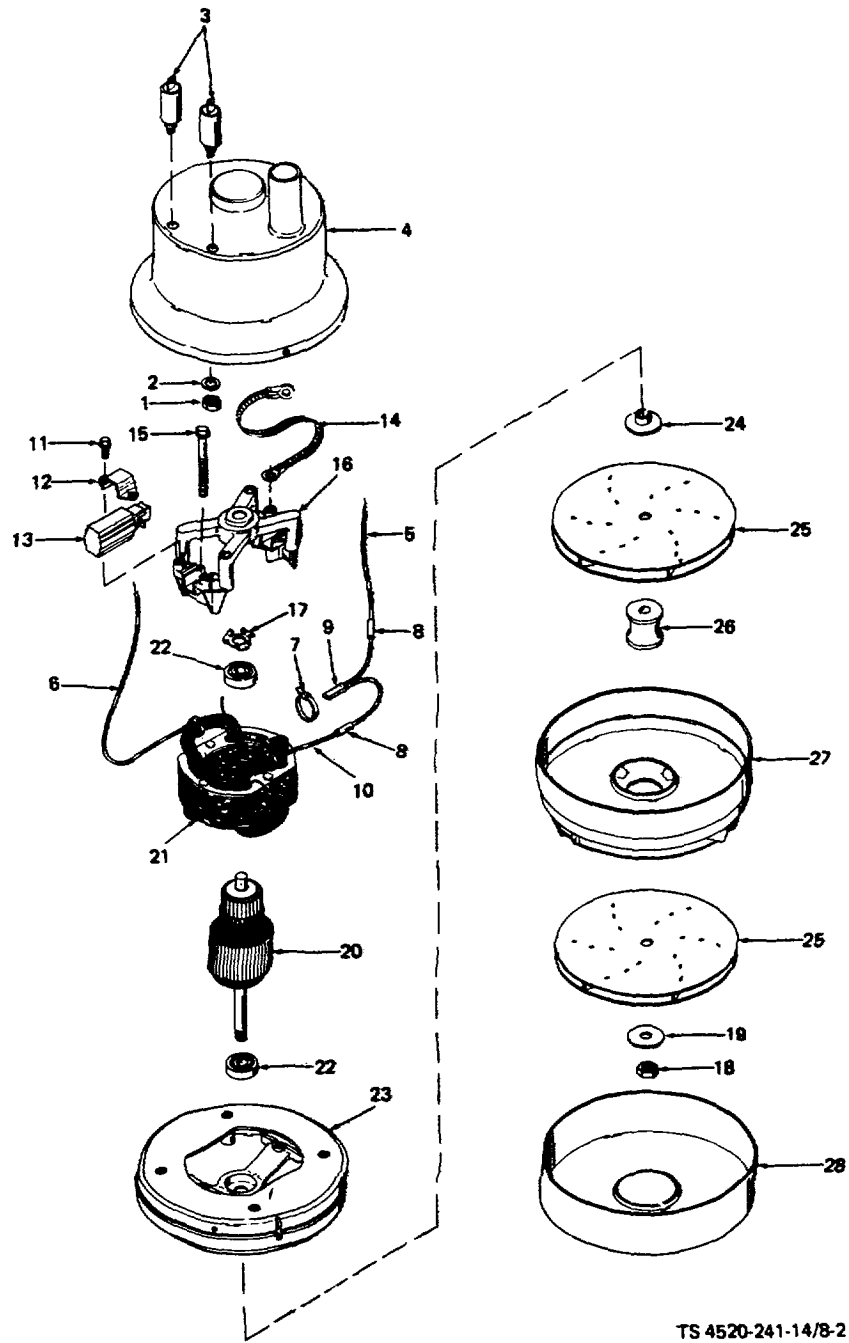

TS 4520-241-14/8-2

Figure 8-2. Combustion motor.

KEY to fig. 8-2:

- | | |
|---------------------------|----------------------------|
| 1. Nut | 15. Field screw |
| 2. Lockwasher | 16. Frame cap |
| 3. Suppression capacitor | 17. Loading spring |
| 4. Motor housing | 18. Nut |
| 5. Wire | 19. Washer |
| 6. Wire | 20. Armature |
| 7. Ty-rap | 21. Field |
| 8. Butt connector | 22. Ball bearing |
| 9. Thermal cutout | 23. Housing frame assembly |
| 10. Wire | 24. Spacer |
| 11. Screw | 25. Fan assembly |
| 12. Clamp | 26. Spacer spool |
| 13. Carbon brush assembly | 27. Upper chamber |
| 14. Ground strap | 28. Lower chamber |

(2) Clean all non-electrical part by immersing in dry cleaning solvent (fed. spec. P-D-680). Wipe thoroughly and allow to dry.

(3) Inspect the fan assemblies for bent or damaged parts. Replace defective fan assemblies.

(4) Inspect the motor brushes for cracks, chips, wear, or scoring. Replace worn brushes.

NOTE

Brushes in the combustion motor are designed to last a minimum of 2,000 hours in operation before replacement.

(5) Inspect the commutator. Replace the armature and bearings if the commutator is scored or badly burned. Light scoring can be cleaned up with fine sandpaper.

(6) Inspect the suppression capacitors (condensers) for any signs of damage. Replace if damaged. Use a capacitance tester to check the capacitors. Capacitance should be 0.47 microfarad $\pm 10\%$. If not, replace the capacitors.

(7) Connect the brown and white leads from the capacitors to the terminal strip as shown on the wiring diagram. Restore power and test the motor.

c. Assembly. Assemble the combustion motor by reversing disassembly sequence. Note the following:

(1) If a new field (21, fig. 8-2) is being installed, carefully inspect the wires (6 and 10) secured to the field winding. The wires supplied with replacement fields are covered with neoprene insulation, which is not acceptable for this application. Cut off the wires and splice on nylon-insulated wires of the correct length.

(2) After the armature has been tightened by torquing nut (18), rotate the armature several turns to check for binding in the fan assemblies.

(3) If a new motor is being installed, cut one black lead and splice in the thermal overload protector using two butt connectors. Fasten the protector to the motor field with Ty-rap.

8-4. VENTILATING MOTOR.

a. Test the operation of the ventilating motor by installing the fan and connecting the motor to an AC ammeter in series with a 120 VAC, 50 or 60 Hz, single phase source.

b. With the motor operating under the fan load, current draw shall not exceed 3.4 amperes. Use a tachometer to check motor speed. It must be approximately 1,425 rpm when operating at 50 Hz and 1,725 rpm when operating at 60 Hz.

c. Replace the motor if the current draw is too high or the speed is too low. No repair is authorized.

8-5. FUEL PUMP POWER SUPPLY.

a. Disassembly.

(1) Remove hardware (1, 2, and 3, fig. 8-3) to remove the assembled fuel pump power supply bracket (4) from the heater case.

(2) If the rectifier is to be replaced, remove nut (5), lock washer (6), and screw (7) to remove rectifier (8). Unsolder all four wires from the terminal strip (12).

(3) Remove nut (9), lock washer (10), and screw (11) to remove terminal strip (12).

(4) Remove the white lead (13), ray lead (14), and yellow lead (15) from their connecting points. The gray lead (14) is connected to the lower overheat thermostat, which must be removed from the bulkhead before pulling off the terminal.

(5) Remove grommet (16). Remove nut (17), lock washer (18), and screw (19) to remove transformer (20). Unsolder the two red wires (21) from the terminal strip.

b. Cleaning and Inspection.



Clean parts in a well-ventilated area. Avoid inhalation of solvent fumes and prolonged exposure of skin to cleaning solvent. Wash exposed skin thoroughly. Dry cleaning solvent (fed. spec. P-D-680) used to clean parts is potentially dangerous to personnel and property. Do not use near open flame or excessive heat. Flash point of solvent is 100°F (38°C).

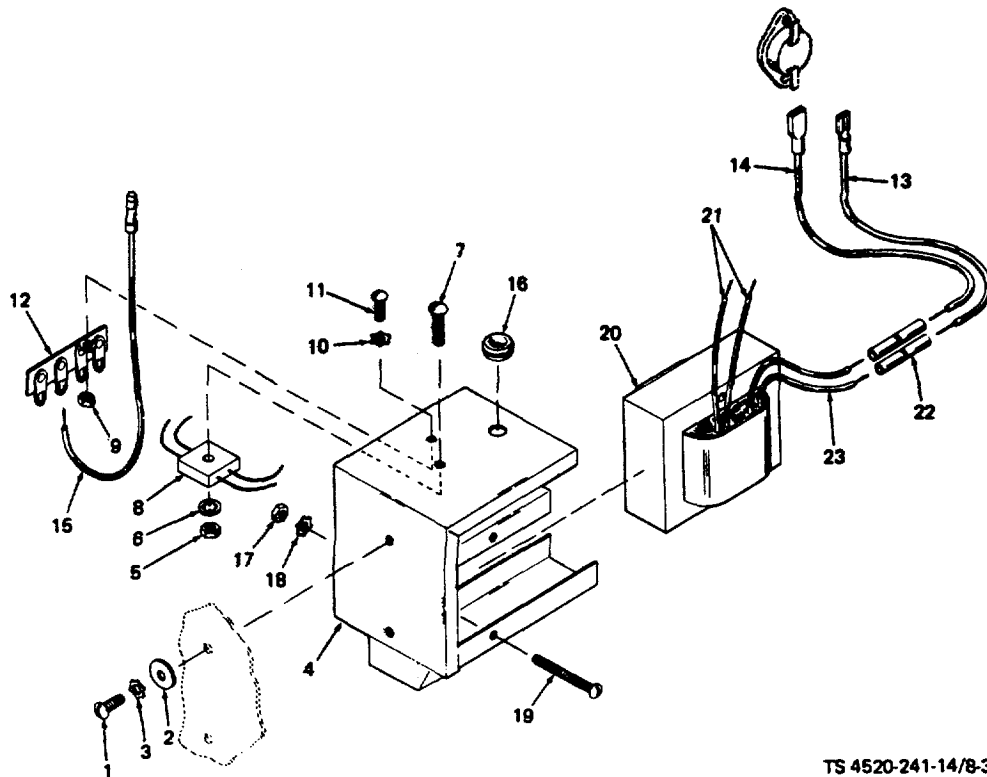

TS 4520-241-14/8-3

- | | |
|--------------------|--------------------|
| 1. Screw | 13. White lead |
| 2. Washer | 14. Gray lead |
| 3. Lock washer | 15. Yellow lead |
| 4. Bracket | 16. Grommet |
| 5. Nut | 17. Nut |
| 6. Lock washer | 18. Lock washer |
| 7. Screw | 19. Screw |
| 8. Rectifier | 20. Transformer |
| 9. Nut | 21. Red wire |
| 10. Lock washer | 22. Butt connector |
| 11. Screw | 23. Black wires |
| 12. Terminal strip | |

Figure 8-3. Fuel pump power supply.

- (1) Clean all electrical parts with a cloth dampened in dry cleaning solvent (fed. spec. P-D-680).
- (2) Clean all non-electrical parts by immersing them in solvent. Wipe thoroughly and allow to dry.
- (3) Check the transformer's operation by applying 120 VAC to the two black wires (23) on the transformer. Check the AC output at the red wires. Voltage should be approximately 30 VAC. If not, replace the transformer.
- (4) Check all leads for cracked, frayed, or broken insulation. Replace defective leads.

(5) Inspect terminals for broken connections or any signs of overheating. Replace defective terminals.

(6) Replace the grommet if it is damaged or does not fit snugly.

c. Assembly. Reassemble the fuel pump power supply in the reverse order of disassembly, and note the following:

(1) If transformer is replaced, connect gray and white leads to the built-in transformer leads with butt connectors (22, fig. 8-3).

(2) If the rectifier is replaced, resolder the connections to the terminal strip according to the wiring diagram. Note that the + terminal of the rectifier is marked with a small dot of paint. The - terminal is diagonally opposite.

(3) Spray all soldered joints with a moisture repellent conforming to MIL-V-173 (Columbia Technical Corporation Humi-Seal, Class A, No. 1A27, or equivalent).

CHAPTER 9
REPAIR OF BURNER ASSEMBLY

9-1. DESCRIPTION.

The burner assembly provides a steady supply of combustion air to the burner head. It also provides a chamber for the mixing and combustion of fuel and air.

9-2. REPAIR.a. Disassembly.

(1) Disconnect the power plug and open the access doors. Disconnect the ignition cable from the igniter (1, fig. 9-1), and remove the igniter from the burner head.

(2) Disconnect the fuel lines at the elbows on the carburetor. Remove the screws securing the carburetor to the burner head. Pull off the carburetor and move it out of the way.

(3) Remove hose clamps (2) and pull air duct (3) off the burner head.

(4) Remove the five screws (4) and pressure pads (5) which fasten the burner head to the heat exchanger. Pry off gasket (6) from burner head (7).

b. Cleaning and Inspection.

(1) Clean the burner by using a wire brush to remove combustion deposits. Clean out all deposits and debris clogging the combustion air inlet or igniter hole.

(2) Inspect all internal baffles in the burner head. Replace the burner head if any baffle is loose or eroded. Minor dents may be straightened, but the burner head must be replaced if there are any cracks or holes, or if there are sizable areas of corrosion.

(3) Discard and replace the burner head gasket. If the air duct is punctured or torn, replace it.

c. Assembly. Assemble in reverse order of disassembly.

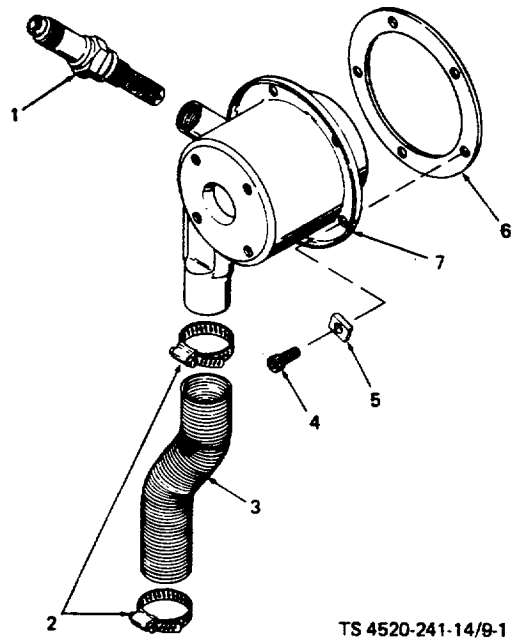

- | | |
|---------------|-----------------|
| 1. Igniter | 5. Pressure pad |
| 2. Hose clamp | 6. Gasket |
| 3. Air duct | 7. Burner head |
| 4. Screw | |

Figure 9-1. Burner assembly

CHAPTER 10

REPAIR OF HEAT EXCHANGER

10-1. DESCRIPTION

The heat exchanger consists of stainless steel stampings welded together to form a maze of passages for the combustion gases. As these gases flow through the heat exchanger, heat is transferred to the heat exchanger walls before the gases are exhausted through the exhaust pipe. The flame switch has a tube that extends through a clamp directly on top of the heat exchanger. Insulation is provided on all sides to reduce heat transfer through the heater case.

10-2. REPAIRa. Disassembly.

- (1) Remove the burner assembly from the heat exchanger at the front of the heater. Pull out insulators (1 and 2, fig. 10-1).
- (2) Remove eight screws (3) and lock washers (4) that secure the rear cover (5) to heater case (6).
- (3) Remove four screws (7) and lock washers (8) that secure the heat exchanger to the rear cover (5). Remove the rear cover.
- (4) Remove four screws (9) and lock washers (10) from support straps (11), and remove shield (12).
- (5) Remove asbestos shield (13), and pull heat exchanger (14) from the heater case.
- (6) Remove screws (15) and lock washers (16) from shield retainers (17), and remove shields (18).
- (7) Remove four screws and lock washers from the front inside of the heater case to release support straps (19) and insulator shield (20).

b. Cleaning and Inspection.**WARNING**

Clean parts in a well-ventilated area. Avoid inhalation of solvent fumes and prolonged exposure of skin to cleaning solvent. Wash exposed skin thoroughly. Dry cleaning solvent (fed. spec. P-D-680) used to clean parts is potentially dangerous to personnel and property. Do not use near open flame or excessive heat. Flash point of solvent is 100°F (38°C).

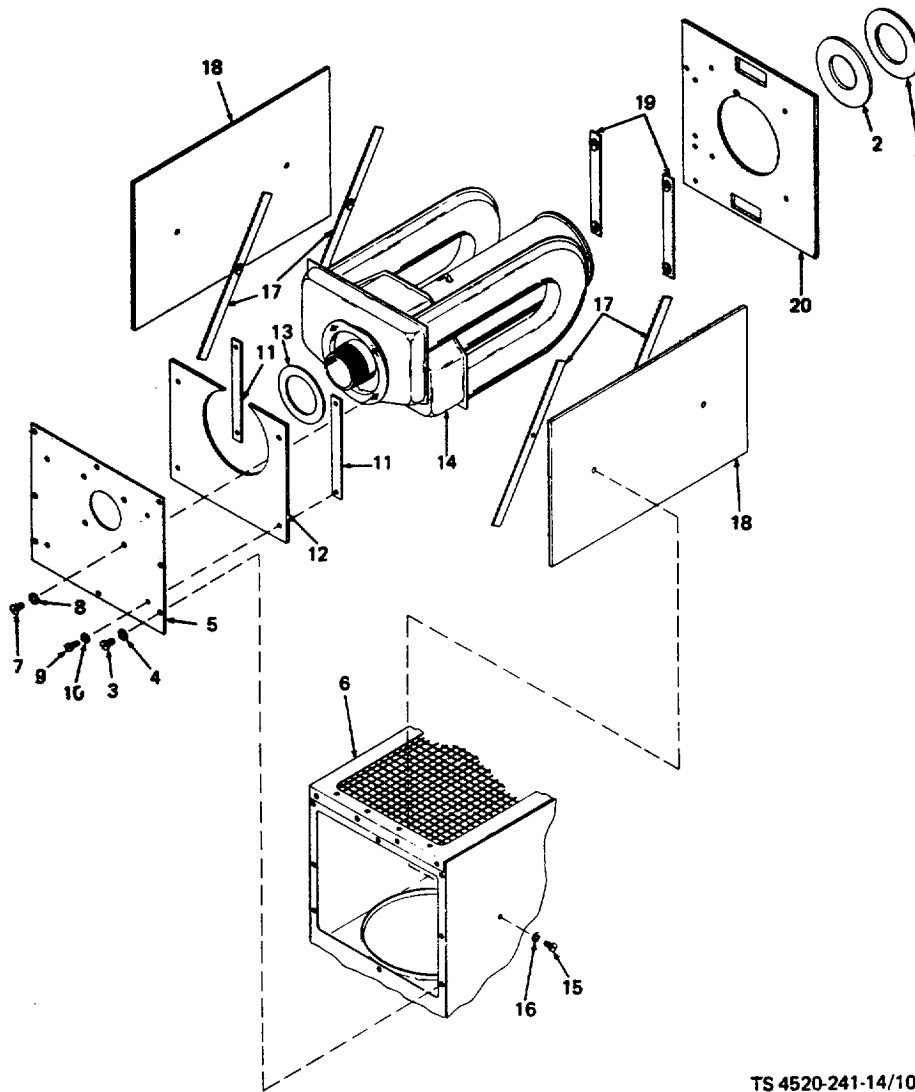

TS 4520-241-14/10-1

- | | |
|-----------------|----------------------|
| 1. Insulator | 11. Support strap |
| 2. Insulator | 12. Shield |
| 3. Screw | 13. Asbestos shield |
| 4. Lock washer | 14. Heat exchanger |
| 5. Rear cover | 15. Screw |
| 6. Heater case | 16. Lock washer |
| 7. Screw | 17. Shield retainer |
| 8. Lock washer | 18. Shield |
| 9. Screw | 19. Support strap |
| 10. Lock washer | 20. Insulator shield |

Figure 10-1. Heat exchanger

- (1) Clean all metallic parts with dry cleaning solvent (fed. spec. P-D-680), and dry thoroughly.
- (2) Wipe the insulating shields with a dry cloth.
- (3) Inspect the heat exchanger for cracks, corroded or burned areas, severe dents, and damaged threads. Replace a damaged heat exchanger.
- (4) Inspect all other parts for cracks, distortion, damaged threads, and other defects. Replace damaged parts.

WARNING

Do not install a heat exchanger which has cracks, broken welds, or holes. Such defects will allow combustion gases containing carbon monoxide, a deadly poison, to contaminate the circulating air.

c. Reassembly. Assemble in reverse order of disassembly. Be careful not to damage the flame switch when inserting the heat exchanger. Restore power and test the heater.

NOTE

The tube extension of the flame switch must pass through the clamp on the top of the heat exchanger.

APPENDIX A

REFERENCES

A-1. FIRE PROTECTION.

TB 5-4200-200-10 Hand Portable Fire Extinguisher For Army Users

A-2. LUBRICATION.

C91001L Fuels, Lubricants, Oils, and Waxes
LO 5-2805-256-12 Lubrication Order

A-3. PAINTING.

TM 9-213 Painting Instructions for Field Use

A-4. RADIO SUPPRESSION.

TM 11-483 Radio Interference Suppression

A-5. MAINTENANCE.

TB 5-4520-224-24P Organizational, Direct and General Support Maintenance Repair Parts
TM 9-237 Welding, Theory and Application
TM 5-2805-256-14 Operator, Organizational, Direct Support, and General Support
Maintenance Manual; Engine, Gasoline, 1-1/2 HP, Military Standard
Models
TM 5-2805-256-24P Organizational, Direct and General Support Maintenance Repair Parts;
Engine, Gasoline, 1-1/2 HP, Military Standard Models
DA PAM 738-750 Army Equipment Record Procedures

A-6. SHIPMENT AND STORAGE.

TB 740-97-2 Preservation of USAMECOM Mechanical Equipment for Shipment and
Storage
TM 740-90-1 Administrative Storage of Equipment
TM 38-230-1 Preservation, Packaging, and Packing of Military Supplies and
Equipment

APPENDIX B

MAINTENANCE ALLOCATION CHART

SECTION I. INTRODUCTION

B-1. GENERAL

a. This section provides a general explanation of all maintenance and repair functions authorized at various maintenance levels.

b. Section II designates overall responsibility for the performance of maintenance functions on the identified end item or component and the work measurement time required to perform the functions by the designated maintenance level. The implementation of the maintenance functions upon the end item or component will be consistent with the assigned maintenance functions.

c. Section III lists the tools and test equipment required for each maintenance function as referenced from Section II.

B-2. EXPLANATION OF COLUMNS IN SECTION II.

a. Column 1. Group Number. Column 1 lists group numbers to identify related components, assemblies, subassemblies, and modules with their next higher assembly. The applicable groups are listed in the MAC in disassembly sequence beginning with the first group removed.

b. Column 2. Component/Assembly. This column contains the noun names of components, assemblies, subassemblies and modules for which maintenance is authorized.

c. Column 3. Maintenance Functions. This column lists the functions to be performed on the item listed in Column 2. The maintenance functions are defined as follows:

(1) Inspect. To determine serviceability of an item by comparing its physical, mechanical, and/or electrical characteristics with established standards through examination.

(2) Test. To verify serviceability and detect incipient failure by measuring the mechanical or electrical characteristics of an item and comparing those characteristics with prescribe standards.

(3) Service. Operations required periodically to keep an item in proper operating condition, i.e., to clean (decontaminated), to preserve, to drain, to paint, or to replenish fuel, lubricants, hydraulic fluids, or compressed air supplies.

(4) Adjust. To maintain within prescribed limits, by bringing into proper or exact position, or by setting the operating characteristics to be specified parameters.

(5) Align. To adjust specified variable elements of an item to bring about optimum or desired performance.

(6) Calibrate. To determine and cause corrections to be made or to be adjust on instruments or test measuring and diagnostic equipments used in precision measurement. Consists of comparison of two instruments, one of which is a certified standard of known accuracy, to detect and adjust any discrepancy in the accuracy of the instrument being compared.

(7) Install. The act of emplacing, seating, or fixing into position an item, part, or module (component or assembly) in a manner to allow the proper functioning of an equipment or system.

(8) Replace. The act of substituting a serviceable like type part, a subassembly, or module (component or assembly) for an unserviceable counterpart.

(9) Repair. The application of maintenance services (inspect, test, service, adjust, align, calibrate, or replace) or other maintenance actions (welding, grinding, riveting, straightening, facing, remachining, or resurfacing) to restore serviceability to an item by correcting specific damage, fault, malfunction, or failure in a part, subassembly, module (component or assembly), end item, or system.

(10) Overhaul. That maintenance effort (service/action) necessary to restore an item to a completely serviceable operational condition as prescribed by maintenance standards (i.e., DMWR) in appropriate technical publications. Overhaul is normally the highest degree of maintenance performed by the Army. Overhaul does not normally return an item to a like-new condition.

(11) Rebuild. Consists of those services/actions necessary for the restoration of unserviceable equipment to a like-new condition in accordance with original manufacturing standards. Rebuild is the highest degree of materiel maintenance applied to Army equipment. The rebuild operation includes the act of returning to zero those age measurement (hours/miles, etc.) considered in classifying Army equipment/components.

d. Column 4. Maintenance Category. This column is made up of sub-columns for each category of maintenance. Work time figures are listed in these sub-columns for the lowest level of maintenance authorized to perform the function listed in Column 3. These figures indicate the average active time required to perform the maintenance function at the indicated category of maintenance under typical field operating conditions.

e. Column 5. Tools and Equipment. This column is provided for referencing by code, the common tool sets (not individual tools) special tools, test and support equipment required to perform the designated function.

(1) GROUP NUMBER	(2) COMPONENT/ASSEMBLY	(3) MAINTENANCE FUNCTION	(4) MAINTENANCE LEVEL					(5) TOOLS AND EQUIPMENT
			C	O	F	H	D	
01	CONTROL BOX ASSEMBLY							
	Control Box	Inspect		0.2				
		Test		0.2				
		Replace		0.2				
	Receptacles, Electrical	Inspect		0.2				
		Replace		1.0				
	Circuit Breaker	Inspect		0.2				
		Replace		0.2				
	Wiring Harness	Inspect		0.2				
		Repair			1.0			
	HEATER-OFF-FAN switch	Inspect		0.2				
		Replace		0.5				
	Time Delay Assembly	Inspect		0.2				
		Replace		1.0		1.0		
	Repair							
PC Board Assembly and Transistor	Inspect		0.2					
	Test			0.3				
	Replace			0.4				
	Repair			0.5				
Time Delay Transformer	Inspect		0.2					
	Replace		0.2					

(1) GROUP NUMBER	(2) COMPONENT/ASSEMBLY	(3) MAINTENANCE FUNCTION	(4) MAINTENANCE LEVEL					(5) TOOLS AND EQUIPMENT	
			C	O	F	H	D		
02	HEATER CASE ASSEMBLY	Inspect		0.1					
		Service		0.2					
		Repair			1.0				
	Side Panels and Louver Linkage	Adjust		0.2					
		Inspect		0.2					
		Service		0.2					
		Replace		0.2					
	Doors and Bottom Cover	Adjust		0.2					
		Inspect		0.2					
		Service		0.2					
Replace			0.2						
Data Plates	Inspect		0.2						
	Replace		0.5						
03	FUEL SYSTEM								
		Fuel Lines and Fittings	Inspect		0.5				
			Repair		0.5				
			Replace		0.5				
		Fuel Filter	Service		0.5				
			Replace		0.5				
		Carburetor	Inspect		0.2				
			Service		0.2				
			Align		0.1				
			Replace		1.0				
		Solenoid	Inspect		0.3				
			Test		0.5				
			Replace		0.5				

(1) GROUP NUMBER	(2) COMPONENT/ASSEMBLY	(3) MAINTENANCE FUNCTION	(4) MAINTENANCE LEVEL					(5) TOOLS AND EQUIPMENT	
			C	O	F	H	D		
04	ELECTRICAL								
	Wiring Harness	Inspect Replace Repair		0.5 1.0	2.0				
	Electrical Receptacles	Inspect Replace		0.2 1.0					
	Combustion Motor	Inspect Repair Replace Test		0.2	0.5 0.5 0.5 1.0				
	Ventilating Motor	Inspect Replace Test		0.2	0.5 0.5				
	Individual Wires, Assemblies, and Terminals	Repair		0.5					
	Safety Thermostats and Flame Switch	Inspect Test Replace		0.2 0.2 0.3					
	Fuel Pump Power Supply	Inspect Test Replace Repair		0.2 0.2 0.5	1.0				
	05	BURNER ASSEMBLY	Repair Replace			1.0 1.0			
		Ignition Transformer and Cable	Replace Repair		0.3 0.2				
Igniter		Service Replace		0.3 0.3					
06	HEAT EXCHANGER	Replace Repair			2.0	2.0			

(1) GROUP NUMBER	(2) COMPONENT/ASSEMBLY	(3) MAINTENANCE FUNCTION	(4) MAINTENANCE LEVEL					(5) TOOLS AND EQUIPMENT
			C	O	F	H	D	
07	ACCESSORY ITEMS							
	Room Thermostat	Adjust Test Replace	0.1	0.5 0.5				
	Side Heater Case Covers	Replace		0.1				
	Plugs; Power, Fuel Pump, and Room Thermostat	Replace		0.3				

APPENDIX C

COMPONENTS OF END ITEMS LIST

SECTION I. INTRODUCTION

C-1. SCOPE.

This appendix lists Integral Components of and Basic Issue Items (BII) for the space heater to help you inventory items required for safe and efficient operation.

C-2. GENERAL.

The components of end item list are divided into the following sections:

a. Section II. Integral Components of the End Item. These items, when assembled, comprise the space heater and must accompany it whenever it is transferred or turned in. These illustrations will help you identify these items.

b. Section III. Basic Issue Items. These are minimum essential items required to place the space heater in operation, to operate it and to perform emergency repairs. Although shipped separately packed, they must accompany the space heater during operation and whenever it is transferred between accountable officers. The illustrations will assist you with hard-to-identify items. This manual is your authority to requisition replacement BII based on Table(s) of Organization and Equipment (TOE)/Modification Table of Organization and Equipment (MTOE) authorization of the end item.

C-3. EXPLANATION OF COLUMNS.

a. Illustration. This column is divided as follows:

(1) Figure Number. Indicates the figure number of the illustration on which the item is shown (if applicable).

(2) Item Number. The number used to identify item called out in the illustration.

b. National Stock Number (NSN). Indicates the national stock number assigned to the end item which will be used for requisitioning.

c. Part Number (P/N). Indicates the primary number used by the manufacturer which controls the design and characteristics of the item by means of its engineering drawings, specifications, standards, and inspection requirements to identify an item or range of items.

d. Description. Indicates the federal item name and, if required, and minimum description to identify the item.

e. Location. The physical location of each item listed is given in this column. The lists are designed to inventory all items in one area of the major item before moving on to an adjacent area.

f. Usable on Code. (Not applicable)

g. Quantity Required (Qty Reqd). This column lists the quantity of each item required for a complete major item.

h. Quantity. This column is left blank for use during inventory. Under the received column, list the quantity you actually receive on your major item. The date columns are for use when you inventory the major item at a later date, such as for shipment to another site.

Section II.

INTEGRAL COMPONENTS OF END ITEM

(1) ILLUSTRATION		(2) NATIONAL STOCK NUMBER	(3) PART NO. & FSCM	(4) DESCRIPTION	(5) LOCATION	(6) USABLE ON CODE	(7) QTY REQD	(8) QUANTITY			
(a) FIGURE NO.	(b) ITEM NO.							RCV'D	DATE	DATE	DATE
		2910-00-710-6054	MS51321-4 (96906)	External Fuel Pump			1				
		5935-00-581-1080	MS3106E14S9P (96906)	Fuel Pump Plug Connector			1				
		5935-00-556-6114	MS3106E18- 10S (96906)	Power Plug Connector			1				
		6685-00-893-9020	68279 (92878)	Room Thermostat			1				
			68635-07 (92878)	Side Cover			2				
		5935-00-201-6655	MS3106E14S7P (96906)	Thermostat Connector			1				
			2-68828 (92878)	Ground Strap			1				

Section III.

BASIC ISSUE ITEMS

(1) ILLUSTRATION		(2) NATIONAL STOCK NUMBER	(3) PART NO. & FSCM	(4) DESCRIPTION	(5) LOCATION	(6) USABLE ON CODE	(7) QTY REQD	(8) QUANTITY			
(a) FIGURE NO.	(b) ITEM NO.							RCV'D	DATE	DATE	DATE
								5220-00-559-9618		Manual Case	
				Department of Army Technical Manual; Operator, Organi- zational, Direct and General Sup- port Maintenance Manual TM 5-4520-241-24P			1				

APPENDIX D

EXPENDABLE SUPPLIES AND MATERIALS LIST

SECTION I. INTRODUCTION

D-1. SCOPE.

This appendix list expendable supplies and materials you will need to operate and maintain the space heater. These items are authorized to you by CTA50-970, Expendable Items (Except Medical, Class V, Repair Parts, and Heraldic Items).

D-2. EXPLANATION OF COLUMNS.

a. Column 1 - Item Number. This number is assigned to the entry in the listing and is referenced in the narrative instruction to identify the material (e.g., "Use cleaning compound, Item 5, App. D").

b. Column 2 - Level. This column identifies the lowest level of maintenance that requires the listed item.

(enter as applicable):

C - Operator/Crew

F - Direct Support Maintenance

O - Organizational Maintenance

H - General Support Maintenance

c. Column 3 - National Stock Number. This is the National stock number assigned to the item; use it to request or requisition the item.

d. Column 4 - Description. Indicates the Federal item name and, if required, a description to identify the item. The last line for each item indicates the part number followed by the Federal Supply Code for Manufacturer (FSCM) in parenthesis, if applicable.

e. Column 5 - Unit of Measure (U/M). Indicates the measure used in performing the actual maintenance function. This measure is expressed by a two-character alphabetical abbreviation (e.g., ea, in, pr). If the unit of measure differs from the unit of issue, requisition the lowest unit of issue that will satisfy your requirements.

Section II.

EXPENDABLE SUPPLIES AND MATERIALS LIST

(1) ITEM NUMBER	(2) LEVEL	(3) NATIONAL STOCK NUMBER	(4) DESCRIPTION	(5) U/M
1	C	9130-00-160-1818	Gasoline, Combat, MIL-G-3056, Type 1 (2 gallons required for 8 hour operation)	Bulk
2	C	9140-00-286-5294	Fuel Oil, Regular, DF-2 (2 gallons required for 8 hour operation)	Bulk
3	C	9140-00-286-5286	Fuel Oil, Winter, DF-1 (2 gallons required for 8 hour operation)	Bulk
4	C	9140-00-286-5283	Fuel Oil, Arctic, DF-A (2 gallons required for 8 hour operation)	Bulk
5	O	6850-00-264-9038	Dry-Cleaning Solvent, P-D-680 Type 1, 5 gallon container (as required)	Gal
6	O	8040-00-828-7385	Sealing Compound, No. 732 RTV, Black, Dow-Corning (71984)	Tube

INDEX

Subject
Paragraph,
Figure, Table
Number

A

Access Doors	
Cleaning and inspection	4-27b
Description	4-24c
Disassembly	F4-19, 4-27a
Preventive maintenance	T4-1
Reassembly	4-27c
Accessory items	T4-1, 4-42
Adjustment:	
Fuel	F4-10, 4-32a
Fuel needle	F4-3, 4-5
Initial checkout and	4-5
Time delay	6-3e
Administrative storage	1-6
Air inlet	T3-1
Assembly (See specific items)	
Axial fan installation	F5-4

B

Base mounting dimensions	F4-1
Bottom cover:	
Cleaning and inspection	4-27b
Description	4-24c
Disassembly	F4-19, 4-27a
Preventive maintenance	T4-1
Reassembly	4-27c
Burner:	
Assembly	9-2c
Cleaning and inspection	9-2b
Description	4-39, 9-1
Disassembly	F9-1, 9-2a
Head	T4-1
Installation	5-15b
Preventive maintenance	T4-1
Removal	5-15a, F5-15
Repair	9-2

C

Cable, ignition	T4-1, F4-30, 4-39b, 4-40
Capacitor, suppression	4-15a, 4-16a
Carburetor:	
Cleaning and inspection	F4-6, F4-11, 4-32d
Description	4-29c
Disassembly	F4-23, 4-32c
Fuel adjustment	4-32a

Subject	Paragraph, Figure, Table Number
Installation.....	4-32f
Preventive maintenance.....	T4-1
Reassembly	4-32e
Removal.....	4-32b
Case, heater:	
Cleaning and inspection	4-25b
Description.....	4-24
Disassembly.....	F4-17, 4-25a
Preventive maintenance.....	T4-1
Reassembly	F4-17, 4-25a
Checkout, initial	4-5
Checks and services, preventive maintenance:	
Operator/crew.....	T3-1, 3-2
Organizational maintenance	T4-1, 4-11
Circuit breaker:	
Cleaning and inspection	4-20b
Description.....	4-19a
Preventive maintenance.....	T4-1
Reassembly and installation	F4-15, 4-20c
Removal and disassembly.....	F4-15, 4-20a
Cleaning (See specific items)	
Combustion motor:	
Assembly	F8-2, 8-3c
Assembly relationships.....	F5-2, F5-12
Cleaning and inspection	8-3b
Description.....	4-34b, 8-1b
Disassembly.....	F8-2, 8-3a
Installation.....	F5-1, 5-12b
Preventive maintenance.....	T4-1
Removal.....	F5-11, 5-12a
Troubleshooting.....	F5-6
Connections, transistor.....	F5-8, F6-4
Control box:	
Cleaning and inspection	4-20b
Cover.....	4-19c, F6-3
Description.....	4-19a, 6-1
Disassembly.....	F4-15, 4-20a
Installation.....	F4-15, 4-20, 5-9b
Preventive maintenance.....	T4-1
Reassembly	F4-15, 4-20c
Removal.....	F4-15, 4-20a, 5-9a
Repair	6-3
Weldment	T4-1
Wiring	F5-9, F6-4
Wiring diagram	F6-2
Wiring harness	4-19b, 4-21, F6-1, 6-1c, 6-2
Controls and receptacles	F2-1, T2-1, 2-2

Subject	Paragraph, Figure, Table Number
Conversion, equipment.....	F4-2, 4-4
Cover assembly, control box.....	4-19c, F6-3
Cover, bottom:	
Cleaning and inspection	4-27b
Description.....	4-24c
Disassembly.....	F4-19, 4-27a
Preventive maintenance.....	T4-1
Reassembly	4-27c
Covers, side:	
Conversion use.....	4-4e
Description.....	4-42b
D	
Data plates	T4-1
Description.....	4-24d
Preventive maintenance.....	T4-1
Replacement	F4-20, 4-28
Data, tabulated	T1-1, 1-8
Description and data	1-7
Destruction of Army materiel to prevent enemy use.....	1-5
Differences in models.....	1-9
Direct support and general support maintenance troubleshooting.....	T5-1, 5-4
Disassembly (See specific items)	
Discharge outlet.....	T3-1
Dismantling for movement	4-6
Doors, access:	
Cleaning and inspection	4-27b
Description.....	4-24c
Disassembly.....	F4-19, 4-27a
Preventive maintenance.....	T4-1
Reassembly	4-27c
E	
Electrical system:	
Combustion motor.....	4-34c, 8-1b, F8-2, 8-3
Description.....	4-35
Fuel pump power supply	F4-29, 4-38, 8-1d, F8-1, 8-5
General maintenance.....	5-6
Igniter.....	4-39c, 4-41
Ignition transformer and cable.....	F4-30, 4-39b, 4-40
Operation.....	F4-25, 4-35
Overheat	4-35e
Overheat thermostat	F4-27, F4-28, 4-34d, 4-37
Preventive maintenance.....	T4-1

Subject	Paragraph, Figure, Table Number
Receptacles	T4-1, 4-19a, 4-20
Room thermostat	F2-2, T4-1, 4-42a, 4-43
Running	4-35c
Shutdown	4-35d
Startup	4-35a
Transition	4-35b
Ventilating motor	4-34c, 8-1c
Wiring harness	T4-1, 4-19b, F4-26, 4-34, 4-36, 5-11, 8-1, F8-1, 8-2
Enemy use, destruction of Army materiel to prevent	1-5
Equipment conversion	F4-2, 4-4
Equipment serviceability criteria	1-4
Errors, reporting of	1-3
Exchanger, heat:	
Cleaning and inspection	10-2b
Description	10-1
Disassembly	F10-1, 10-2a
Installation	5-16b
Insulator installation	F5-5, F5-17, 5-16b
Reassembly	10-2c
Removal	5-16a, F5-16
External connection	T3-1
External fuel pump	T3-1
Extreme cold, operation in	2-7

F

Fan, axial:	
Installation	F5-4
Fan mode, operation in	2-5
Filter and receptacle assembly	4-15b, 4-16b
Filter, fuel	T4-1, F4-22, 4-29a, 4-31
Flame switch:	
Mounting	F4-4
Forms and records, maintenance	1-2
Fuel:	
Adjustment	F4-10, 4-32a
External fuel pump	T3-1
Filter	T4-1, F4-22, 4-29a, 4-31
Fittings	T4-1, F4-21, 4-29, 4-30
Lines	3-7, T4-1, F4-21, 4-29, 4-30

Subject	Paragraph, Figure, Table Number
Mixer and jet.....	F4-7, F4-12
Needle adjustment.....	F4-3, 4-5, 4-32a
Pump, external.....	T3-1
Supply.....	T3-1, 3-6
System.....	T4-1
Fuel pump power supply:	
Assembly.....	8-5c
Cleaning and inspection.....	8-5b
Description.....	4-34e, 8-1d
Disassembly.....	F8-3, 8-5a
Installation.....	4-38c
Preventive maintenance.....	T4-1
Removal.....	F4-29, 4-38a
Repair.....	4-38b
H	
Hardware, general maintenance of.....	5-8
Harness, wiring:	
Assembly.....	8-2c
Cleaning and inspection.....	6-2b, 8-2b
Description.....	4-19b, 4-34, 6-1c, 8-1a
Disassembly.....	F6-1, 6-2a, F8-1, 8-2a, T4-1
Preventive maintenance.....	T4-1
Reassembly.....	6-2c
Removal and replacement.....	F4-26, 4-36, 5-11
Heat exchanger:	
Cleaning and inspection.....	10-2b
Description.....	10-1
Disassembly.....	F10-1, 10-2a
Installation.....	5-16b
Insulator installation.....	F5-5, 5-16b, F5-17
Reassembly.....	10-2c
Removal.....	F5-16, 5-16a
Heater case:	
Cleaning inspection.....	4-25b
Description.....	4-24, 7-1
Disassembly.....	F4-17, 4-25a
Installation.....	5-10b
Preventive maintenance.....	T4-1
Reassembly.....	4-25c
Removal.....	5-10a
Repair.....	F7-1, 7-2
Heater mode, operation in.....	2-4
HEATER-OFF-FAN switch:	
Description.....	6-1b
Inspection.....	4-22a

Subject	Paragraph, Figure, Table Number
Installation.....	4-22c
Preventive maintenance.....	T4-1
Removal.....	4-22b
Wiring.....	F4-16
Heater/sensor:	
Checking continuity.....	6-3a
Installation.....	F5-10
High altitudes, operation at.....	2-8
I	
Identification and tabulated data.....	1-8
Igniter:	
Cleaning and inspection.....	4-41b
Description.....	4-39c
Installation.....	4-41c
Preventive maintenance.....	T4-1
Removal.....	F4-30, 4-41a
Ignition cable.....	T4-1, F4-30, 4-39b, 4-40
Ignition transformer:	
Assembly.....	F4-30, 4-40c
Cleaning and inspection.....	4-40b
Description.....	4-39b
Disassembly.....	F4-30, 4-40a
Initial checkout and adjustment.....	4-5
Inspecting and servicing the equipment.....	4-1
Inspection (See specific items)	
Installation (See specific items)	
Installation of separately packed components.....	4-2
Installation instructions.....	4-3
Inverted mounting.....	4-4d
L	
Locating the heater.....	4-3
Louver linkage:	
Cleaning and inspection.....	4-26b
Description.....	4-24b
Disassembly.....	F4-18, 4-26a
Preventive maintenance.....	T4-1
Reassembly.....	4-26c
M	
Maintenance:	
Electrical components.....	5-6
Forms and records.....	1-2
Mechanical components.....	5-7
Of fuel lines.....	3-7
Of fuel supply.....	3-6

Subject	Paragraph, Figure, Table Number
Preventive	T3-1, 3-2, T4-1, 4-11
Prior to storage	1-6d
Repair parts.....	4-9, 5-3
Major components and assemblies, removal of:	
Burner assembly.....	5-15
Combustion motor.....	5-12
Control box.....	5-9
Fuel pump power supply	5-14
Heat exchanger	5-16
Heater case assembly.....	5-10
Ventilating motor.....	5-13
Wiring harness	5-11
Mechanical components:	
General maintenance.....	5-7
Models, differences in	1-9
Modification for mounting.....	F4-2, 4-4
Motor combustion:	
Assembly	F8-2, 8-3c
Assembly relationships.....	F5-2, F5-12
Cleaning and inspection	8-3b
Description.....	4-34b, 8-1b
Disassembly.....	F8-2, 8-3a
Installation.....	F5-1, 5-12b
Preventive maintenance.....	T4-1
Removal.....	F5-11, 5-12a
Troubleshooting.....	F5-6
Motor, ventilating:	
Description.....	4-34c, 8-1c
Fan dimension	F5-14, 5-14b
Installation.....	F5-3, 5-13b, F5-13
Preventive maintenance.....	T4-1
Removal.....	F5-13, 5-13a
Mounting:	
Dimensions	F4-1
Modifications required for.....	F4-2
Movement:	
Dismantling for.....	4-6
Reinstallation after	4-7
O	
On-off switch (See HEATER-OFF-FAN switch)	
Operation:	
At high altitudes	2-8
General	2-1
In extreme cold	2-7
In fan mode	2-5
In heater mode	2-4
Under rainy or humid conditions.....	2-9

Subject	Paragraph, Figure, Table Number
Operator/crew maintenance:	
Preventive maintenance.....	3-1, T3-1
Troubleshooting.....	T3-2, 3-4
Organizational maintenance:	
Preventive maintenance.....	T4-1, 4-11
Troubleshooting.....	T4-2, 4-12
Overheat	4-35e
Overheat thermostat:	
Cleaning and inspection	4-37b
Description.....	4-34d
Installation.....	F4-27, F4-28, 4-37c
Removal.....	F4-27, 4-37a

P

Panels, side:	
Cleaning and inspection	4-26b
Description.....	4-24b
Disassembly.....	F4-18, 4-26a
Preventive maintenance.....	T4-1
Reassembly	4-26c
PC board assembly:	
Cleaning and inspection	6-3c
Description.....	6-1d
Installation.....	F5-7
Preventive maintenance.....	T4-1
Reassembly	6-3d
Removal and disassembly.....	6-3b
Testing.....	6-3a
Plates, data:	
Description.....	4-24d
Preventive maintenance.....	T4-1
Replacement	F4-20, 4-28
Power receptacle	4-15b
Power supply, fuel pump:	
Assembly	8-5c
Cleaning and inspection	8-5b
Description.....	4-34e, 8-1d
Disassembly.....	F8-3, 8-5a
Installation.....	4-38c
Preventive maintenance.....	T4-1
Removal.....	F4-29, 4-38a
Repair	4-38b
Preventive maintenance checks and services:	
Operator/crew.....	T3-1, 3-2
Organizational maintenance	T4-1, 4-11
Primary interference suppression components.....	4-15

Subject	Paragraph, Figure, Table Number
Radio interference suppression:	
General methods	4-14
Primary interference components.....	4-15
Secondary interference components	4-17
Testing.....	4-18
Rainy or humid conditions, operation under	2-9
Reassembly (See specific items)	
Receptacle, power	4-15b, 4-16b
Receptacle, room thermostat	6-1a
Receptacles and controls	F2-1, T2-1 2-2, T4-1
Receptacles, electrical:	
Cleaning and Inspection	4-20b
Description.....	4-19a
Reassembly and installation	F4-15, 4-20c
Removal and disassembly.....	F4-15, 4-20a
Reinstallation after movement.....	4-7
Removal (See specific items)	
Repair parts, maintenance.....	4-9, 5-3
Reporting of errors	1-3
Room thermostat:	
Description.....	F2-2, 4-42a
Preventive maintenance.....	T4-1
Receptacle	6-1a
Reassembly	4-43b
Testing.....	4-43a
S	
Safety thermostats:	
Cleaning and inspection	4-37b
Description.....	F4-27, 4-34d
Installation.....	F4-27, F4-28 4-37c
Removal.....	4-37a
Scope	1-1
Secondary interference suppression components	4-17
Separately packed components, installation of.....	4-2
Servicing and inspecting the equipment.....	4-1
Shutdown	4-35d
Shutoff	2-6
Side covers:	
Conversion use.....	4-4e
Description.....	4-42b
Side panels:	
Cleaning and Inspection	4-26b
Description.....	4-24b
Disassembly.....	F4-18, 4-26a
Preventive maintenance.....	T4-1
Reassembly	4-26c

Subject	Paragraph, Figure, Table Number
Solenoid valve:	
Description.....	4-29d
Preventive maintenance.....	T4-1
Replacement.....	F4-24, 4-33b
Testing.....	4-33a
Troubleshooting.....	F4-8, F4-13
Special tools and equipment:	
Direct support and general support maintenance.....	5-2
Organizational maintenance.....	4-8
Standby heaters, servicing.....	3-3
Starting.....	2-3
Startup.....	4-35a
Stopping.....	2-6
Storage, administrative.....	1-6
Suppression components, replacement of.....	4-14
Suppression, general methods used to attain proper.....	4-14
Switch, flame, mounting.....	F4-4
Switch, HEATER-OFF-FAN:	
Description.....	6-1b
Inspection.....	4-22a
Installation.....	4-22c
Preventive maintenance.....	T4-1
Removal.....	4-22b
Wiring.....	F4-16

T

Tabulated data.....	T1-1, 1-8
Thermostat, overheat:	
Cleaning and inspection.....	4-37b
Description.....	4-34d
Installation.....	F4-27, F4-28, 4-37c
Removal.....	F4-27, 4-7a
Thermostat, room:	
Description.....	F2-2, 4-42a
Preventive maintenance.....	T4-1
Replacement.....	4-43b
Testing.....	4-43a
Thermostats, safety:	
Cleaning and inspection.....	4-37b
Description.....	F4-27, 4-34d
Installation.....	F4-27, F4-28, 4-37c
Removal.....	4-37a
Time delay assembly:	
Adjustment.....	6-3e
Cleaning and inspection.....	6-3c
Description.....	6-1e
Preventive maintenance.....	T4-1
Reassembly and installation.....	6-3d
Removal and disassembly.....	6-3b

Subject	Paragraph, Figure, Table Number
Testing.....	6-3a
Transformer.....	T4-1, 4-19d, 4-23
Tools and equipment:	
Direct support and general support maintenance.....	5-1
Organizational maintenance.....	4-8
Transformer, ignition:	
Assembly.....	F4-30, 4-40c
Cleaning and inspection.....	4-40b
Description.....	4-39b
Disassembly.....	F4-30, 4-40a
Transformer, time delay:	
Description.....	4-19d
Preventive maintenance.....	T4-1
Replacement.....	4-23b
Testing.....	4-23a
Transition.....	4-35b
Transistor:	
Connections.....	F5-8, F6-4
Description.....	6-1d
Installation.....	F5-7
Preventive maintenance.....	T4-1
Troubleshooting:	
Direct support and general support maintenance.....	T5-1, 5-4
Operator/crew maintenance.....	T3-2, 3-4
Organizational maintenance.....	T4-2, 4-12

V

Valve, solenoid:	
Description.....	4-29d
Preventive maintenance.....	T4-1
Replacement.....	F4-24, 4-33b
Testing.....	4-33a
Ventilating motor:	
Description.....	4-34c, 8-1c
Fan dimension.....	F5-14, 5-14b
Installation.....	F5-3, 5-13b, F5-13
Preventive maintenance.....	T4-1
Removal.....	F5-13, 5-13a

W

Wiring, control box.....	F5-9, F6-4
Wiring diagram.....	F6-2
Wiring harness:	
Assembly.....	8-2c
Cleaning and inspection.....	6-2b, 8-2b
Description.....	4-19b, 4-34, 6-1c, 8-1a

Subject	Paragraph, Figure, Table Number
Disassembly.....	F6-1, 6-2a, F8-1, 8-2a
Preventive maintenance.....	T4-1
Reassembly	6-2c
Removal and replacement	F4-26, 4-36, 5-11

By Order of the Secretary of the Army:

Official:

E. C. MEYER
General, United States Army
Chief of Staff

J. C. PENNINGTON
Major General, United States Army
The Adjutant General

DISTRIBUTION:

To be distributed in accordance with DA Form 12-25C, Operator's Organizational, Direct and General Support for Heaters, Space 60,000 BTU.

☆ U.S. GOVERNMENT PRINTING OFFICE: 2000 O - 461-711 (20809)

RECOMMENDED CHANGES TO EQUIPMENT TECHNICAL MANUALS



SOMETHING WRONG WITH THIS MANUAL?

THEN... JOT DOWN THE DOPE ABOUT IT ON THIS FORM. TEAR IT OUT, FOLD IT AND DROP IT IN THE MAIL!

FROM: (YOUR UNIT'S COMPLETE ADDRESS)
 PFC JOHN DOE
 COA, 3rd ENGINEER BN
 FT. LEONARD WOOD MO 63108

DATE

PUBLICATION NUMBER

TM 5-4520-241-14

DATE

15 Jul 80

TITLE

Heater, Space, Multi-Fuel, With Blower, 60,000 BTU/hr (Heater/Multi-Fuel)

BE EXACT... PIN-POINT WHERE IT IS

IN THIS SPACE TELL WHAT IS WRONG AND WHAT SHOULD BE DONE ABOUT IT:

PAGE NO.

PARA-GRAPH

FIGURE NO.

TABLE NO.

6

2-1
a

In line 6 of paragraph 2-1a the manual states the engine has 6 cylinders. The engine on my set only has 4 cylinders. Change the manual to show 4 cylinders.

81

4-3

Callout 16 on figure 4-3 is pointing at a bolt. In the key to fig. 4-3, item 16 is called a shim. Please correct one or the other.

125

line 20

~~SAMPLE~~

Ordered a gasket, item 19 on figure B-16 by NSN 2910-00-762-3001. I got a gasket but it doesn't fit. Supply says I got what I ordered, so the NSN is wrong. Please give me a good NSN.

TYPED NAME, GRADE OR TITLE, AND TELEPHONE NUMBER

JOHN DOE, PFC (268) 317-7111

SIGN HERE:

John Doe

DA FORM 2028-2
1 AUG 74

P.S.—IF YOUR OUTFIT WANTS TO KNOW ABOUT YOUR MANUAL "FIND," MAKE A CARBON COPY OF THIS AND GIVE IT TO YOUR HEADQUARTERS. DRSTS-M Overprint 1, 1 Nov 78

TEAR ALONG DOTTED LINE

FILL IN YOUR
UNIT'S ADDRESS



FOLD BACK

DEPARTMENT OF THE ARMY



OFFICIAL BUSINESS

Commander
US Army Troop Support and Aviation
Materiel Readiness Command
ATTN: DRSTS-MTPS
4300 Goodfellow Boulevard
St. Louis, MO 63120

TEAR ALONG DOTTED LINE

FOLD BACK

The Metric System and Equivalents

Linear Measure

1 centimeter = 10 millimeters = .39 inch
 1 decimeter = 10 centimeters = 3.94 inches
 1 meter = 10 decimeters = 39.37 inches
 1 dekameter = 10 Meters = 32.8 feet
 1 hectometer = 10 dekameters = 328.08 feet
 1 kilometer = 10 hectometers = 3,280.8 feet

Weights

1 centigram = 10 milligrams = .15 grain
 1 decigram = 10 centigrams = 1.54 grains
 1 gram = 10 decigram = 0.35 ounce
 1 dekagram = 10 Grams = .35 ounce
 1 hectogram = 10 dekagrams = 3.52 ounces
 1 kilogram = 10 hectograms = 2.2 pounds
 1 quintal = 100 kilograms = 220.46 pounds
 1 metric ton = 10 quintals = 1.1 short tons

Liquid Measure

1 centiliter = 10 milliliters = .34 fluid ounce
 1 deciliter = 10 centiliters = 3.38 fluid ounces
 1 liter = 10 deciliters = 38.82 fluid ounces
 1 dekaliter = 10 liters = 2.64 gallons
 1 hectoliter = 10 dekaliters = 26.42 gallons
 1 kiloliter = 10 hectoliters = 264.18 gallons

Square Measure

1 sq. centimeter = 100 sq millimeters = .155 sq. inch
 1 sq. decimeter = 100 sq centimeters = 15.5 sq. inches
 1 sq. meter (centare) = 100 sq decimeters = 10.76 sq. feet
 1 sq. dekameter (are) = 100 sq. meters = 1,076.4 sq. feet
 1 sq. hectometer (hectare) = 100 sq. dekameters = 2.47 acres
 1 sq. kilometer = 100 sq. hectometers = .386 sq. mile

Cubic Measure

1 cu. centimeter = 1000 cu. millimeters = 06 cu. inch
 1 cu. decimeter = 1000 cu. decimeters = 61.02 cu. inches
 1 cu. meter = 1000 cu. decimeters = 35.31 cu. feet

Approximate Conversion Factors

<i>To change</i>	<i>To</i>	<i>Multiply by</i>	<i>To change</i>	<i>To</i>	<i>Multiply by</i>
inches	centimeters	2.540	ounce-inches	newton-meters	.007062
feet	meters	.305	centimeters	inches	.394
yards	meters	.914	meters	feet	3.280
miles	kilometers	1.609	meters	yards	1.094
square inches	square centimeters	6.451	kilometers	miles	.621
square feet	square meters	.093	square centimeters	square inches	.155
square yards	square meters	.836	square meters	square feet	10.764
square miles	square kilometers	2.590	square meters	square yards	1.196
acres	square hectometers	.405	square kilometers	square miles	.386
cubic feet	cubic meters	.028	square hectometers	acres	2.471
cubic yards	cubic meters	.765	cubic meters	cubic feet	35.315
fluid ounces	milliliters	29.573	cubic meters	cubic yards	1.308
pints	liters	.473	milliliters	fluid ounces	.034
quarts	liters	.946	liters	pints	2.113
gallons	liters	3.785	liters	quarts	1.057
ounces	grams	28.349	liters	gallons	.264
pounds	kilograms	.454	grams	ounces	.035
short tons	metric tons	.907	kilograms	pounds	2.205
pound-feet	newton-meters	1.356	metric tons	short tons	1.102
pounds-inches	newton-meters	.11375			

Temperature (Exact)

°F	Fahrenheit temperature	5/9 (after subtracting 32)	Celsius temperature	°C
----	------------------------	----------------------------	---------------------	----

